



**ROHDE & SCHWARZ**

Service manual

**SIGNAL GENERATOR  
SMPD**

376.8011.52

Printed in West Germany

VOLUME III

Manual consists of 3 volumes



# Contents of SMPD Manual

## VOLUME I

1. Data Sheet
2. Preparation for Use and Operating Instructions
3. Maintenance

## VOLUME II

4. Service Instructions for Complete Unit
5. Service Instructions for PC Boards Y1 to Y10

## VOLUME III

5. Service Instructions for PC Boards Y11 to Y105,  
Option SMPD-B1 and Option SMPD-B2

Contents

5

Service Instructions for PC Boards Y11 to Y40

Y	Designation	Ident Number	PC Board	Lead	Parts Designation	Register
11	PLL	356.0980 .02	356.0996 356.1011 300.5657	355.9848	Control Amplifier Pulse Processing Circuit Sampling Unit	1
12	Amplitude Modulator and ALC	300.7414 .02	300.5434	300.5474		2
13	Output Stage I	300.2612	300.5470	300.5492		3
12	Output Stage II	300.3560	300.5511	300.5534		4
15	Output Stage III	376.9318 .02	376.9324	376.9376		5
19	Front panel	376.8211 .02	355.9902 355.9860 300.5734		Keyboard/ Display Control Stage Connections Board	6
20	Output Amplifier	300.1816 .04	300.5792 .04			7
25	Power Supply	376.8511 .02	355.9731 .02 355.9719 .02 355.9754 300.5970 300.5034 376.9018 .02		Voltage Regulator +5, +15 V Electrolytic Capacitor Board Voltage Regulator Power- supply Feed IEC-bus Board Controller	8
30	RF Attenuator	377.0214	377.0220 302.7311		Control Attenuator	9
40	10-MHz Crystal Oscillator	300.2412	300.5634 300.5611		Crystal Oscillator Temperature Control	

## Notes on Service Instructions for SMPD Subassemblies

For spare-part acquisition and stock-keeping, it is important to note that most of the subassemblies are taken unmodified from the Signal Generator SMPC. The designation SMPC in the following text should be read as SMPD.

The subassemblies Y1, Y15, Y19, Y25 and Y30 have been modified.

New additions are the subassemblies Y100 to Y105, the Pulse Modulator Option SMPD-B1, and Overload Protection Option SMPD-B2.

Supplement to Table of Contents, Volume III.

Y	Name	Order No.	PCB No.	Section
100	Controller	376.9418	376.9418	10
101	Diode switch I	914.9303	--	10
102	Diode switch II	914.9403	--	10
103	Broadband amplifier	376.9199	376.9218	10
104	Filter	914.9503	--	10
105	Frequency doubler	376.9501	376.9518	10
	Pulse Modulator Option SMPD-B1	377.0914	377.0922	10
	Overload Protection Option SMPD-B2	377.1110	--	10



**ROHDE & SCHWARZ**

SERVICE INSTRUCTIONS FOR

PLL

356.0980 (Y11)

## 5.1 Circuit Description

(See circuit diagram 356.0980 S and Fig. 5-1)

Y11 comprises a sampling mixer (B20) as a phase detector, the associated pulse processing circuit and a control amplifier in which the presetting voltage from oscillator control (Y10) and the phase control voltage are added.

### 5.1.1 Pulse Processing Circuit

The pulse arriving from the buffer divider of interpolation oscillator II (Y5) is applied via TR1 to amplifier T2 which triggers a pulse shaper with step-recovery diode. T1 controls the DC operating point of the pulse amplifier. The sampler is driven with antiphase pulses via the balun TR2.

### 5.1.2 Sampling Unit

To ensure a high return loss, the RF from output oscillator I (Y8) is applied via two switchable amplifiers (B21, B22) and an attenuator to the sampler (B20) which supplies a phase difference voltage at each harmonic of the 20-MHz pulse from the buffer divider.

### 5.1.3 Control Amplifier

The control amplifier consists of individual transistors which provide the required wide bandwidth. The phase difference voltage available at the output difference of the difference source follower T30 is converted into a current (T31 to T34) and in R55 added to the presetting voltage from oscillator control (Y10). The two subsequent band-pass filters for 20 MHz and 40 MHz suppress residual impulses from the sampling mixer. The operational amplifier B30 supplies the difference of the source voltage of T30 to the oscillator control (Y10) for monitoring the PLL.

## 5.2 Checking and Adjustment Procedures

### 5.2.1 Checking the Frequency Response of the Phase Difference Voltage

Setup on Y11:

- Feed 20-MHz pulses from the buffer divider into ST145. For this purpose, set frequency on XPC/SMPC to 240 MHz.
- Feed signal source from 680 to 1360 MHz with a level of  $-3 \pm 0,5$  dBm into ST143. The harmonic content of the signal generator must be  $< -25$  dBc.

Set 680.02 MHz on signal generator and measure AF voltage at ST144 by means of oscilloscope. Then increase frequency in 20-MHz steps until 1360.02 MHz is reached at the same time checking the voltage at ST144.

The phase difference voltage must be sinusoidal over the entire frequency range. The amplitude should be  $450 \pm 80$  mV<sub>pp</sub>.

### 5.2.2 Transmission of the Presetting Voltage

Setup on Y11:

- Connect power supply (0 to 20 V) to ST142.
- Connect voltmeter to ST144.

Set voltage successively to 0.8 and 18 V. The offset voltage between ST142 and ST144 should in each case be  $< \pm 100$  mV.

### 5.2.3 Checking the Monitoring Voltage

Setup on Y11:

- Connect voltmeter to ST141.  
All other connectors of the Y11 are unoccupied.

The DC voltage at ST141 should be  $0.65 \pm 0.3$  V.

## 5.3 Troubleshooting

### 5.3.1 Sampling Unit

RF level: output B21:  $6 \pm 1$  dBm,  
output B22:  $8 \pm 1$  dBm.

Pulse amplitude at B20.9, B20.10:  $\dots 6 \pm 2$  V  
(500- $\Omega$  probe, oscilloscope bandwidth  $>1.5$  GHz).

### 5.3.2 Pulse Processing Circuit

Collector T2:  $11 \pm 1$  V DC without signal.

### 5.3.3 Interface

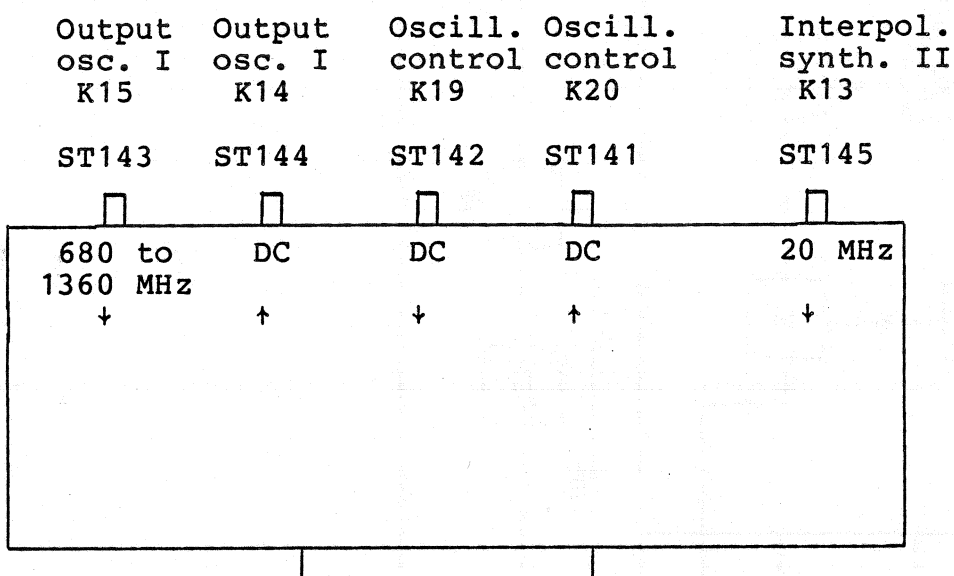

ST/BU	141	142	143	144	145
f	DC	DC	680 to 1360MHz	DC	20 MHz
Level	$\approx 0.5$ V	1 to 17V	$-3 \pm 2$ dBm	1 to 17V	narrow pulse $\approx -5$ V <sub>p</sub>
Z	100 $\Omega$	100 k $\Omega$	50 $\Omega$	100 $\Omega$	50 $\Omega$
AC-DC	DC	DC	AC	DC	DC (trans- former) pulsed
Shape of curve	DC	DC	sinusoidal	DC	

ST 140.13

H = PLL on  
L = PLL off

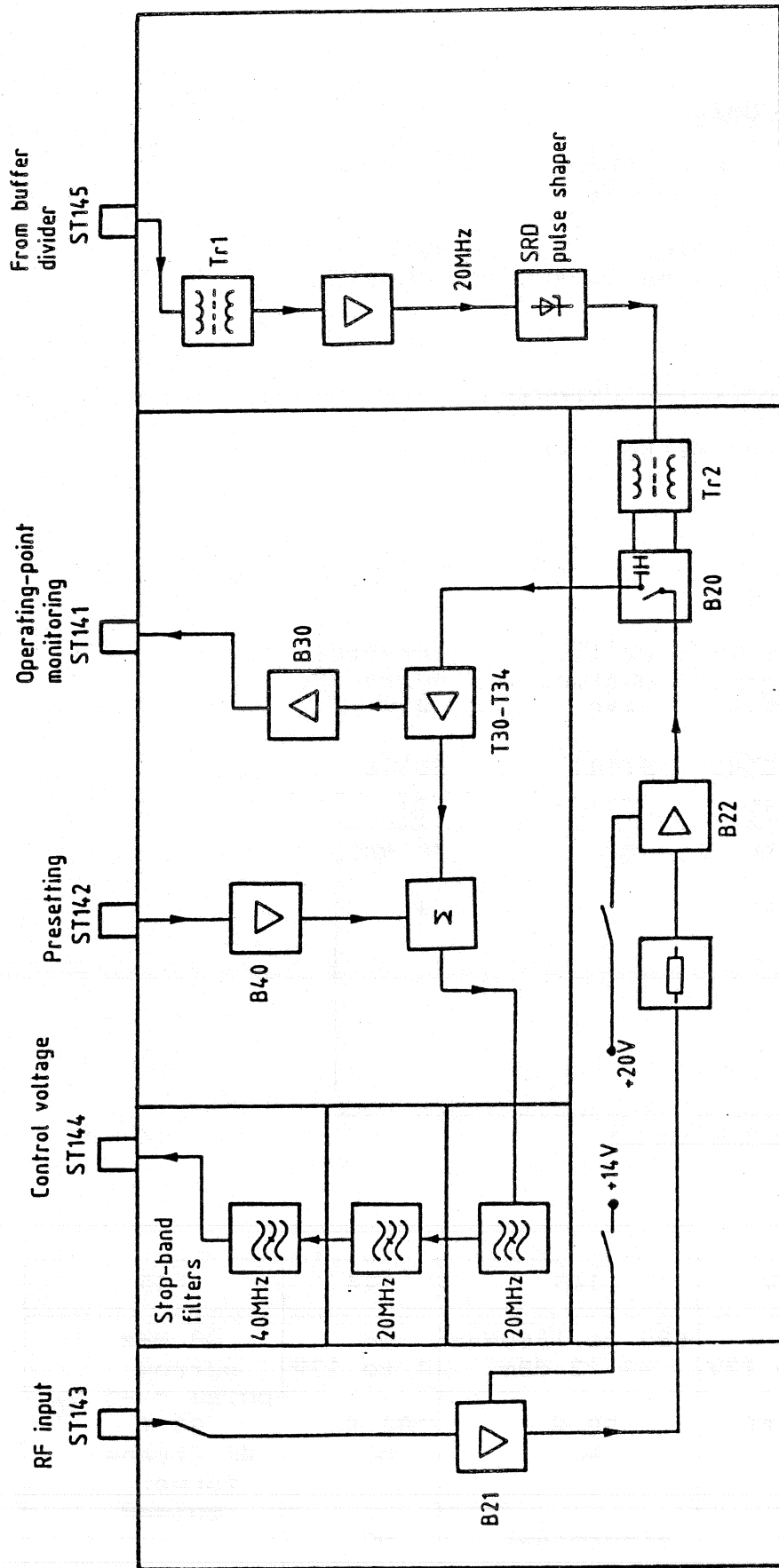

Fig. 5-1 Block diagram of PLL





ROHDE & SCHWARZ  
MÜNCHEN

Schalteillisten  
Stromläufe  
Bestückungspläne  
Parts lists  
Circuit diagrams  
Components plans

**ROHDE & SCHWARZ**

ÄZ	Datum
05	0686

Schaltteilliste für Parts list for ED PHASENREGELUNG
--

Sachnummer Stock No.
356.0980.01 SA

Blatt Page
1

Kennzeichen Component No.	Benennung/Beschreibung Designation	Sachnummer Stock No.	enthalten in contained in
B20	BD MISCHER MIXER	914.5608	356.1011.01
B21	DUENNSCHICHT.SPZ.-TEIL BD VERST.0,1-2GHZ/9DB 20V IC AMPLIFIER 0,1-2GHZ 9DB	911.6826	356.1011.01
B22	DUENNSCHICHT.SPZ.-TEIL BD VERST.0,1-2GHZ/9DB 20V IC AMPLIFIER 0,1-2GHZ 9DB	911.6826	356.1011.01
B30	BO LF156J BIFET OPAMP OPERATIONAL AMPLIFIER MOTOROLA LF 156 J	BO 645.7251	356.1011.01
B40	BO SE5534AFE LOW N.OPAMP OPERATIONAL AMPLIFIER SIGNETICS SE5534AFE	BO 301.3335	356.1011.01
BU1	FP BUCHSE VERTIKAL P.V.1P SOCKET BERG 75377-001	FP 278.5577	356.1011.01
BIS/T0 BU4			
C1	CC 3,3PF+-0,25PF3X4NPO CAPACITOR VALVO 2222 678 09338	CC 087.6364	356.1011.01
C2	CC 1NF+-10%63V K2000 CERAMIC CAPACITOR VALVO 2222 63051 102	CC 022.0784	356.1011.01
C3	CC 4,7NF+-10%6X9R2000 CAPACITOR VALVO 2222 63051 472	CC 087.7102	356.1011.01
C4	CE 10 UF+-20%25V 7X 5X11 ELECTROLYTIC CAPACITOR ERO-TANTAL ETR3-10/25	CE 023.5980	356.1011.01
C5	CC 4,7NF+-10%6X9R2000 CAPACITOR VALVO 2222 63051 472	CC 087.7102	356.1011.01
C6	CE 10 UF+-20%25V 7X 5X11 ELECTROLYTIC CAPACITOR ERO-TANTAL ETR3-10/25	CE 023.5980	356.1011.01
C7	CC 4,7NF+-10%6X9R2000 CAPACITOR VALVO 2222 63051 472	CC 087.7102	356.1011.01
C8	CE 22UF-10+50% 63V 9X13 ELECTROLYTIC CAPACITOR ROEDERST EK 00 CB 222 J	CE 006.7120	356.1011.01
C9	CC 680PF+-10%4X5R2000 CAPACITOR VALVO 2222 63051 681	CC 087.7019	356.1011.01
C10	CC 15PF+-10%100V3NPO CHIP CAPACITOR VITRAMON VJ1005A150KFB	CC 082.3009	356.1011.01
C11	CC 15PF+-10%100V3NPO CHIP CAPACITOR VITRAMON VJ1005A150KFB	CC 082.3009	356.1011.01

356.0980.01 SA BL 1+

Für diese Unterlage behalten wir  
uns alle Rechte vor

**ROHDE & SCHWARZ**

ÄZ	Datum
05	0686

 Schalteilliste für  
 Parts list for  
 ED PHASENREGELUNG

Sachnummer	Blatt
Stock No.	Page
356.0980.01 SA	2

Kennzeichen Component No.	Benennung/Beschreibung Designation	Sachnummer Stock No.	enthalten in contained in
C12	CE 1,0UF+-20%35V 5X 4X 7 ELECTROLYTIC CAPACITOR ERO-TANTAL TA-ELKOETR1-1/35	CE 022.8185	356.1011.01
C20	CE 1,0UF+-20%35V 5X 4X 7 ELECTROLYTIC CAPACITOR ERO-TANTAL TA-ELKOETR1-1/35	CE 022.8185	356.1011.01
C21	CC 2,1PF+-0,25PF50V2NPO CAPACITOR VITRAMON VJ0805A2R1CFA	CC 093.5550	356.1011.01
C22	CC 3,6PF+-0,25PF50V2NPO CAPACITOR VITRAMON VJ0805A3R6CFA	CC 093.5614	356.1011.01
C23	CK 100NF+-5%63V5RM MKT CAPACITOR WIMA MKS/2/63/0,1UF/5%	CK 099.2930	356.1011.01
C24	CC 3,9PF+-0,25PF3X4NPO CAPACITOR VALVO 2222 678 09398	CC 087.6370	356.1011.01
C25	CK 100NF+-5%63V5RM MKT CAPACITOR WIMA MKS/2/63/0,1UF/5%	CK 099.2930	356.1011.01
C26	CE 10UF -10+50% 63V 9X13 ELECTROLYTIC CAPACITOR ROEDERST ELKOEK10/63	CE 022.7650	356.1011.01
C27	CE 10UF -10+50% 63V 9X13 ELECTROLYTIC CAPACITOR ROEDERST ELKOEK10/63	CE 022.7650	356.1011.01
C30	CE 1,0UF+-20%35V 5X 4X 7 ELECTROLYTIC CAPACITOR ERO-TANTAL TA-ELKOETR1-1/35	CE 022.8185	356.1011.01
C31	CK 100NF+-5%63V5RM MKT CAPACITOR WIMA MKS/2/63/0,1UF/5%	CK 099.2930	356.1011.01
C32	CK 100NF+-5%63V5RM MKT CAPACITOR WIMA MKS/2/63/0,1UF/5%	CK 099.2930	356.1011.01
C34	CC 150PF+-2%6X9N150 CAPACITOR VALVO 2222 678 34151	CC 087.6735	356.1011.01
C35	CC 10NF-20+50%7X8R6000 CAPACITOR VALVO 2222 63051 64051103	CC 087.7525	356.1011.01
C37	CE 22UF-10+50% 63V 9X13 ELECTROLYTIC CAPACITOR ROEDERST EK 00 CB 222 J	CE 006.7120	356.1011.01
C38	CC 390PF+-10%3X4R2000 CAPACITOR VALVO 2222 63051 391	CC 087.6987	356.1011.01
C39	CE 22UF-10+50% 63V 9X13 ELECTROLYTIC CAPACITOR ROEDERST EK 00 CB 222 J	CE 006.7120	356.1011.01
C40	CC 4,7NF+-10%6X9R2000 CAPACITOR VALVO 2222 63051 472	CC 087.7102	356.1011.01
C41	CE 22UF-10+50% 63V 9X13 ELECTROLYTIC CAPACITOR ROEDERST EK 00 CB 222 J	CE 006.7120	356.1011.01

356.0980.01 SA BL 2+

**ROHDE & SCHWARZ**

ÄZ	Datum
05	0686

Schaltteilliste für Parts list for ED PHASENREGELUNG
--

Sachnummer Stock No.
356.0980.01 SA

Blatt Page
3

Kennzeichen Component No.	Benennung/Beschreibung Designation	Sachnummer Stock No.	enthalten in contained in
C42	CK 330NF+-5%63V5RM MKT CAPACITOR WIMA MKS2/63/0,33UF/5%	CK 099.2969	356.1011.01
C43	CC 22PF+-2%3X4N150 CAPACITOR VALVO 2222 678 34229	CC 087.6635	356.1011.01
C44	CK 330NF+-5%63V5RM MKT CAPACITOR WIMA MKS2/63/0,33UF/5%	CK 099.2969	356.1011.01
C45	CC 4,7NF+-10%6X9R2000 CAPACITOR VALVO 2222 63051 472	CC 087.7102	356.1011.01
C46	CE 22UF-10+50% 63V 9X13 ELECTROLYTIC CAPACITOR ROEDERST EK 00 CB 222 J	CE 006.7120	356.1011.01
C60	CC 68PF+-2%5X6N150 CAPACITOR VALVO 2222 678 34689	CC 087.6693	356.1011.01
C61	CC 6,8PF+-0,25PF3X4N150 CAPACITOR VALVO 2222 678 33688	CC 087.6570	356.1011.01
C62	CC 120PF+-2%6X9N150 CAPACITOR VALVO 2222 678 34121	CC 087.6729	356.1011.01
C63	CC 10PF+-0,25PF3X4N150 CAPACITOR VALVO 2222 678 33109	CC 087.6593	356.1011.01
C64	CC 56PF+-2%5X6N150 CAPACITOR VALVO 2222 678 34569	CC 087.6687	356.1011.01
C65	CC 15PF+-2%3X4N150 CAPACITOR VALVO 2222 678 34159	CC 087.6612	356.1011.01
C66	CC 33PF+-2%4X5N150 CAPACITOR VALVO 2222 678 34339	CC 087.6658	356.1011.01
C67	CC 12PF+-2%3X4N150 CAPACITOR VALVO 2222 678 34129	CC 087.6606	356.1011.01
C68	CC 6,8PF+-0,25PF3X4N150 CAPACITOR VALVO 2222 678 33688	CC 087.6570	356.1011.01
D1	LD 35DB/200M-10GHZ PI-FIL CHOKE ERIE. 1214-038	LD 300.6818	356.0996.01
BIS/T0 D4			
GL1	AE 5082-0833 25V STEPR.DI DIODE	AE 343.0086	356.1011.01
GL20	HEWLETT-P. 5082-0833 AD 1N4448 75V 0,15A UDI DIODE VALVO 1N4448	AD 012.0700	356.1011.01

356.0980.01 SA BL 3+

Für diese Unterlage behalten wir  
uns alle Rechte vor



ROHDE & SCHWARZ

ÄZ Datum  
Date  
05 0686

Schaltteilliste für  
Parts list for  
ED PHASENREGELUNG

Sachnummer  
Stock No.

356.0980.01 SA

Blatt  
Page

4

Kennzeichen Component No.	Benennung/Beschreibung Designation	Sachnummer Stock No.	enthalten in contained in
L1	SPULE	356.1063	356.1011.01
L2	LD 10,0UH10%3,300HMO,144A CHOKE	LD 026.4184	356.1011.01
L20	DELEVAN DROSSEL1025-44 ENTHALTEN IN/INCLUDED IN 356.1011/PCB		356.1011.01
L21	LD 10,0UH10%3,300HMO,144A CHOKE	LD 026.4184	356.1011.01
L22	DELEVAN DROSSEL1025-44 LD 10,0UH10%3,300HMO,144A CHOKE	LD 026.4184	356.1011.01
L50	DELEVAN DROSSEL1025-44 LD 10,0UH10%3,300HMO,144A CHOKE	LD 026.4184	356.1011.01
L51	DELEVAN DROSSEL1025-44 LD 10,0UH10%3,300HMO,144A CHOKE	LD 026.4184	356.1011.01
L60	DELEVAN DROSSEL1025-44 LD 0,82UH 5%,850HMO,420A HIGH FREQUENCY CHOKE	355.9890	356.1011.01
L61	DELEVAN 1025-18 +-5% LD 0,47 UH +-5%/,8A0,30HM CHOKE	067.3230	356.1011.01
L62	INDUSTRIA DROSSEL1025-12+5% LD 0,82UH 5%,850HMO,420A HIGH FREQUENCY CHOKE	355.9890	356.1011.01
L63	DELEVAN 1025-18 +-5% LD 0,47 UH +-5%/,8A0,30HM CHOKE	067.3230	356.1011.01
L64	INDUSTRIA DROSSEL1025-12+5% LD 0,82UH 5%,850HMO,420A HIGH FREQUENCY CHOKE	355.9890	356.1011.01
R1	RL 0,35W22,10 OHM+-1%TK50 RESISTOR	RL 082.9188	356.1011.01
R2	DRALORIC SMA0207/22,10HM-F-D RL 0,35W 68,1 OHM+-1%TK50 RESISTOR	RL 082.9636	356.1011.01
R3	DRALORIC SMA0207/68,10HM-F-D RL 0,35W 10,0KOHM+-1%TK50 RESISTOR	RL 083.1297	356.1011.01
R4	DRALORIC SMA0207/10K-F-D RL 0,35W 47,5KOHM+-1%TK50 RESISTOR	RL 083.1800	356.1011.01
R5	DRALORIC SMA/207/47,5K-F-C RL 0,35W 11,3KOHM+-1%TK50 RESISTOR	RL 082.2202	356.1011.01
R6	DRALORIC SMA0207/11,3K-F-C RL 0,35W 221 OHM+-1%TK50 RESISTOR	RL 083.0084	356.1011.01
R7	DRALORIC SMA0207/2210HM-F-D RL 0,21W 100 OHM2% UNGEW. RESISTOR	RL 092.5956	356.1011.01
	RESISTA MK1 100OHM 2% UNGEW.		

356.0980.01 SA BL 4+

**ROHDE & SCHWARZ**

ÄZ	Datum
05	0686

Schaltteilliste für Parts list for ED PHASENREGELUNG
--

Sachnummer Stock No.
356.0980.01 SA

Blatt Page
5

Kennzeichen Component No.	Benennung/Beschreibung Designation	Sachnummer Stock No.	enthalten in contained in
R8	RL 0,21W 1,0KOHM2% UNGEW. RESISTOR RESISTA MK1 1K 2% UNGEW.	RL 092.6075	356.1011.01
R9	RL 0,35W 1,50KOHM+-1%TK50 RESISTOR DRALORIC SMA0207/1,50K-F-D	RL 083.0732	356.1011.01
R20	RL 0,35W6,81KOHM+-0,1%T25 RESISTOR DRALORIC SMA0207/6,81K-B-E	RL 084.2745	356.1011.01
R21	RL 0,35W825 OHM+-0,1%TK25 RESISTOR DRALORIC SMA0207	RL 083.8985	356.1011.01
R22	RL 0,21W 180 OHM2% UNGEW. RESISTOR RESISTA MK1 180OHM 2% UNGEW.	RL 092.5985	356.1011.01
R23	RL 0,21W 33 OHM2% UNGEW. RESISTOR RESISTA MK1 33OHM 2% UNGEW.	RL 092.5891	356.1011.01
R24	RL 0,21W 180 OHM2% UNGEW. RESISTOR RESISTA MK1 180OHM 2% UNGEW.	RL 092.5985	356.1011.01
R25	RL 0,35W 10,0KOHM+-1%TK50 RESISTOR DRALORIC SMA0207/10K-F-D	RL 083.1297	356.1011.01
R26	RL 0,35W 4,75KOHM+-1%TK50 RESISTOR DRALORIC SMA0207/4,75K-F-D	RL 083.1097	356.1011.01
R27	RL 0,35W 10,0KOHM+-1%TK50 RESISTOR DRALORIC SMA0207/10K-F-D	RL 083.1297	356.1011.01
R28	RL 0,35W 4,75KOHM+-1%TK50 RESISTOR DRALORIC SMA0207/4,75K-F-D	RL 083.1097	356.1011.01
R29	RL 0,35W 4,75KOHM+-1%TK50 RESISTOR DRALORIC SMA0207/4,75K-F-D	RL 083.1097	356.1011.01
R30	RL 0,35W 4,75KOHM+-1%TK50 RESISTOR DRALORIC SMA0207/4,75K-F-D	RL 083.1097	356.1011.01
R31	RL 0-WIDERSTAND DIN 0204 0-OHM RESISTOR DRALORIC OMA 0204	RL 069.0000	356.1011.01
R35	RL 0,35W796 OHM+-0,1%TK25 RESISTOR DRALORIC SMA0207	RL 083.8956	356.1011.01
R36	RL 0,35W9,65KOHM+-1%T25 RESISTOR DRALORIC SMA0207/9,65K-B-E	RL 084.3035	356.1011.01
R37	RL 0,35W 100 OHM+-1%TK50 METALFILM-RESISTOR DRALORIC SMA0207/100/HM-F-D	RL 082.6543	356.1011.01
R39	RL 0,35W 100KOHM+-1%TK50 RESISTOR DRALORIC SMA0207/100K-F-C	RL 082.1764	356.1011.01
R40	RL 0,35W 100KOHM+-1%TK50 RESISTOR DRALORIC SMA0207/100K-F-C	RL 082.1764	356.1011.01

356.0980.01 SA BL 5+

Für diese Unterlage behalten wir  
uns alle Rechte vor



Kennzeichen Component No.	Benennung/Beschreibung Designation	Sachnummer Stock No.	enthalten in contained in
R41	RL 0,35W 2.74MOHM+-1%TK50 METALFILMRESISTOR	RL 099.8980	356.1011.01
R42	RESISTA MK2 2.74MOHM+-1%TK50 RL 0,35W 100KOHM+-1%TK50 RESISTOR	RL 082.1764	356.1011.01
R43	DRALORIC SMA0207/100K-F-C RL 0,35W 100KOHM+-1%TK50 RESISTOR	RL 082.1764	356.1011.01
R44	DRALORIC SMA0207/100K-F-C RL 0,35W 475 OHM+-1%TK50 RESISTOR	RL 083.0390	356.1011.01
R45	DRALORIC SMA0207/475OHM-F-D RL 0,35W 2,61KOHM+-1%TK50 RESISTOR	RL 083.0903	356.1011.01
R46	DRALORIC SMA0207/2,61K-F-D RL 0,35W 2,61KOHM+-1%TK50 RESISTOR	RL 083.0903	356.1011.01
R47	DRALORIC SMA0207/2,61K-F-D RL 0,35W 475 OHM+-1%TK50 RESISTOR	RL 083.0390	356.1011.01
R48	DRALORIC SMA0207/475OHM-F-D RL 0,35W 825 OHM+-1%TK50 RESISTOR	RL 082.2502	356.1011.01
R49	DRALORIC SMA 0207/825OHM-F-C RL 0,35W 221 OHM+-1%TK50 RESISTOR	RL 083.0084	356.1011.01
R50	DRALORIC SMA0207/221OHM-F-D RL 0,35W 221 OHM+-1%TK50 RESISTOR	RL 083.0084	356.1011.01
R51	DRALORIC SMA0207/221OHM-F-D RL 0,35W 110 OHM+-1%TK50 RESISTOR	RL 082.9813	356.1011.01
R52	DRALORIC SMA0207/110OHM-F-D RL 0-WIDERSTAND DIN 0204 0-OHM RESISTOR	RL 069.0000	356.1011.01
R53	DRALORIC OMA 0204 RL 0,35W 2,21KOHM+-1%TK50 RESISTOR	RL 082.2477	356.1011.01
R54	DRALORIC SMA 0207/2,21K-F-C RL 0,35W 2,21KOHM+-1%TK50 RESISTOR	RL 082.2477	356.1011.01
R55	DRALORIC SMA 0207/2,21K-F-C RL 0,35W 68,1 OHM+-1%TK50 RESISTOR	RL 082.9636	356.1011.01
R56	DRALORIC SMA0207/68,1OHM-F-D RL 0,35W 1KOHM+-1%TK50 RESISTOR	RL 082.2160	356.1011.01
R57	DRALORIC SMA0207/1K-F-C RL 0,35W 1MOHM+-1%TK50 RESISTOR	RL 082.7862	356.1011.01
R58	DRALORIC SMA0207/1M-F-D RL 0,35W 1KOHM+-1%TK50 RESISTOR	RL 082.2160	356.1011.01
R60	DRALORIC SMA0207/1K-F-C RL 0,35W 22,10 OHM+-1%TK50 RESISTOR	RL 082.9188	356.1011.01
	DRALORIC SMA0207/22,10HM-F-D		

**ROHDE & SCHWARZ**

ÄZ	Datum
05	0686

Schaltteilliste für Parts list for
ED PHASENREGELUNG

Sachnummer Stock No.
356.0980.01 SA

Blatt Page
7

Kennzeichen Component No.	Benennung/Beschreibung Designation	Sachnummer Stock No.	enthalten in contained in
ST1	FP EINZELKONTAKTSTIFT SINGLE-CONTACT PIN ULMIC R&S.ZCHNG.300.8804	300.8804	356.0996.01
BIS/T0 ST4 ST140	ENTHALTEN IN/INCLUDED IN 356.0996/PCB		356.0996.01
ST141	FJ EINBAUWINKELST. SMC ANGLE CONNECTOR RADIALL R 112 669	FJ 249.9684	356.1011.01
BIS/T0 ST145			
T1	AK BCY79IX PNP 45V 200MA TRANSISTOR SIEMENS BCY79IX	AK 010.3777	356.1011.01
T2	AK BFR96 NPN 15V 5GHZ TRANSISTOR VALVO BFR96	AK 093.2738	356.1011.01
T21	AK 2N2907A PNP 60V 600MA TRANSISTOR VALVO 2N2907A	AK 010.3583	356.1011.01
T22	AK 2N2907A PNP 60V 600MA TRANSISTOR VALVO 2N2907A	AK 010.3583	356.1011.01
T23	AK BCY59IX NPN 45V 200MA TRANSISTOR SIEMENS BCY59IX	AK 010.5163	356.1011.01
T30	AM U440 NKAN-DUAL-FET FET SILICONIX U440	AM 336.4696	356.1011.01
T31	AK 2N2907A PNP 60V 600MA TRANSISTOR VALVO 2N2907A	AK 010.3583	356.1011.01
T32	AK 2N2907A PNP 60V 600MA TRANSISTOR VALVO 2N2907A	AK 010.3583	356.1011.01
T33	AK 2N2222A NPN 40V 800MA TRANSISTOR VALVO 2N2222A	AK 010.5405	356.1011.01
T34	AK 2N2222A NPN 40V 800MA TRANSISTOR VALVO 2N2222A	AK 010.5405	356.1011.01
TR1	LU UEBERTRAGER	356.1057	356.1011.01
TR2	LU UEBERTRAGER	356.1040	356.1011.01
			- ENDE -

356.0980.01 SA BL 7-

Für diese Unterlage behalten wir  
uns alle Rechte vor



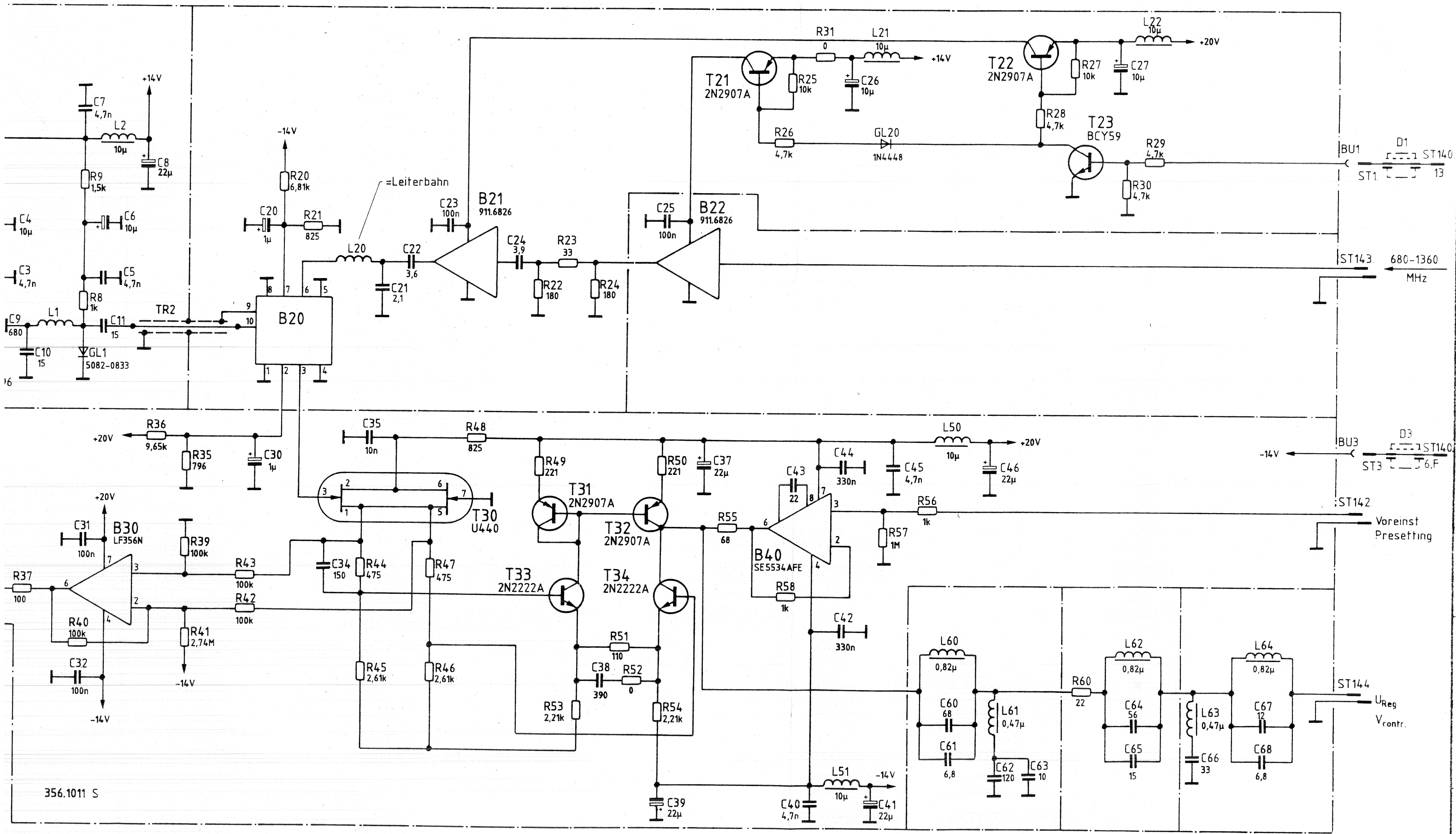

356.1011 S

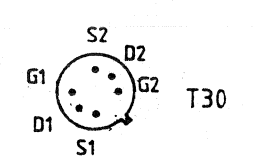
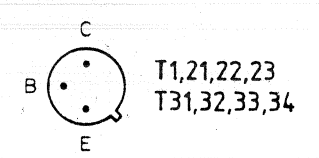
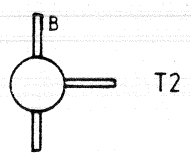

	Stromlauf zu		Z	Zeichn.-Nr	Blatt-Nr
	Phasenregelung / Phase control				
SMPC	reg I V	355.9519 V	erste Z	300.1000	356.0980 S
					v Bl

Name	
Datum	
Nr.	
zust.	
Name	
Datum	
Nr.	
zust.	
wir uns alle Rechte vor	
<b>ROHDE &amp; SCHWARZ</b>	
Name	
Datum	
Nr.	
zust.	
Zeichn.-Nr.	330.V700.3
1KGA	L.w.d.m
gezeichnet	12.83
geprüft	12.83
bearbeitet	gs
normgepr.	

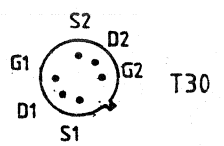
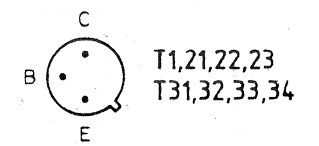
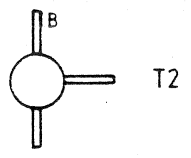
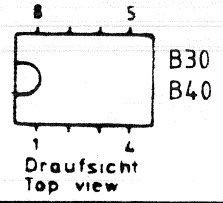
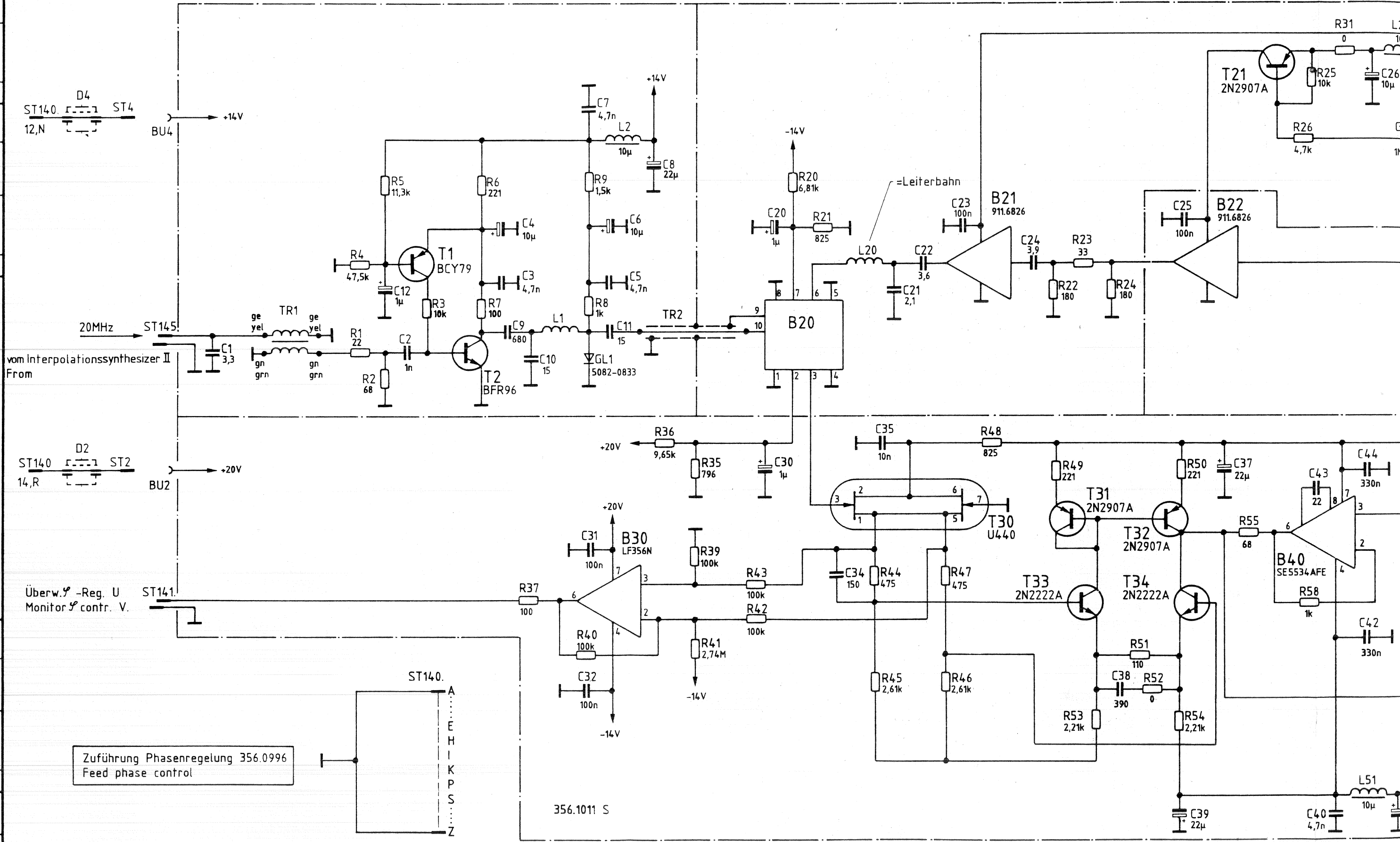

Für diese Unterlage behalten wir uns alle Rechte vor.

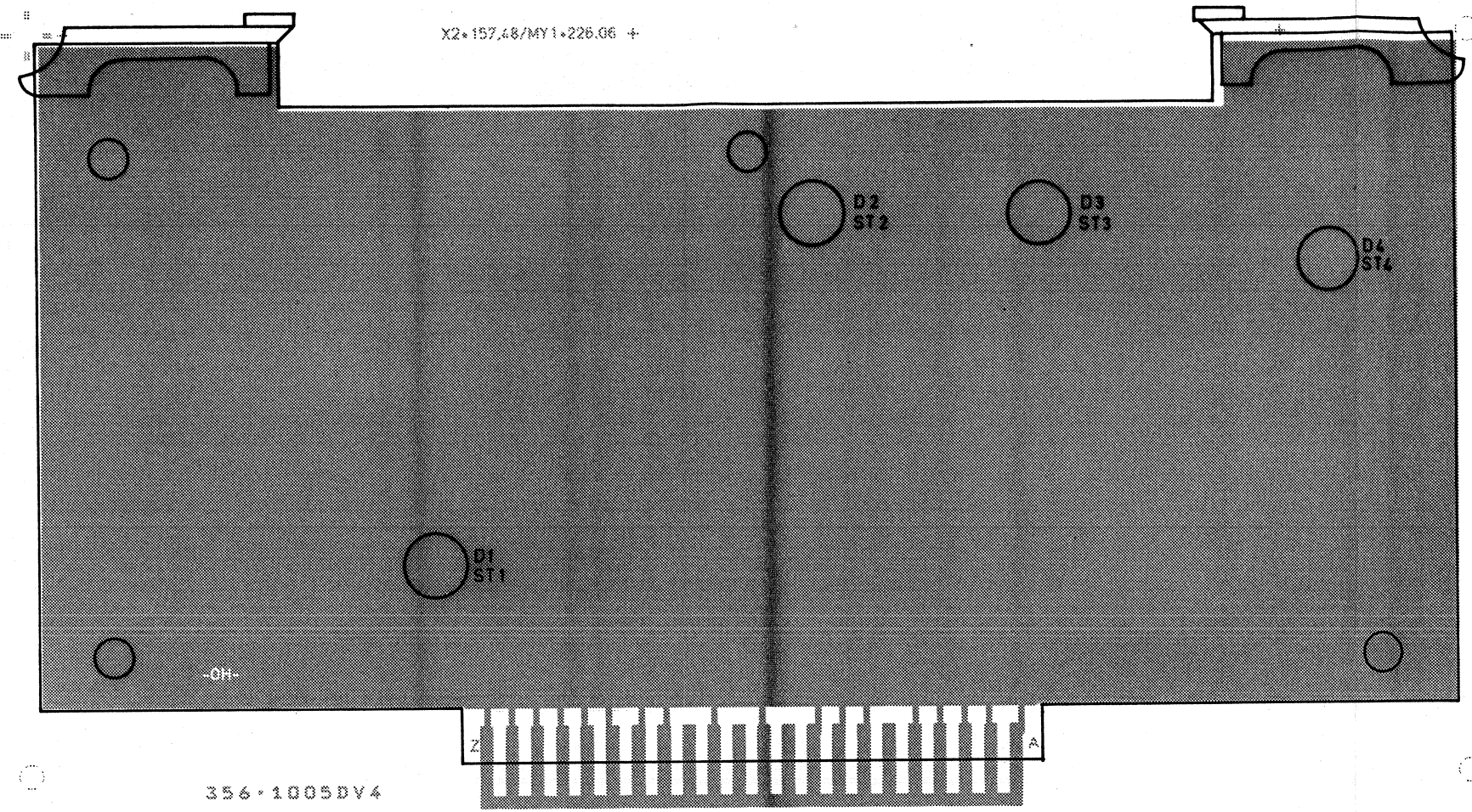

Ansicht und Leitungsführung Bauteilseite  
View of tracks on component side

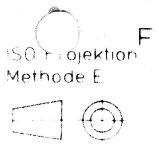

		Maße ohne Toleranzangabe		Maßstab 1:1		Halbzeug, Werkstoff	
		1KGA	Tag	Name	Benennung		Z
		Bearb	12.83	GS	Zuführ. Phasenregelung FEED PHASE CONTROL		
		Gepr					
		Norm					
				Zeichn. Nr.		Blatt-Nr.	
		zu Gerät SMPC		356.0996		2	
And. Zust.	Anderungs-Mitteilung	Tag	Name	reg. V	355.9519 V	erste Z	356.0980



Für diese Unterlage behalten wir uns alle Rechte vor.

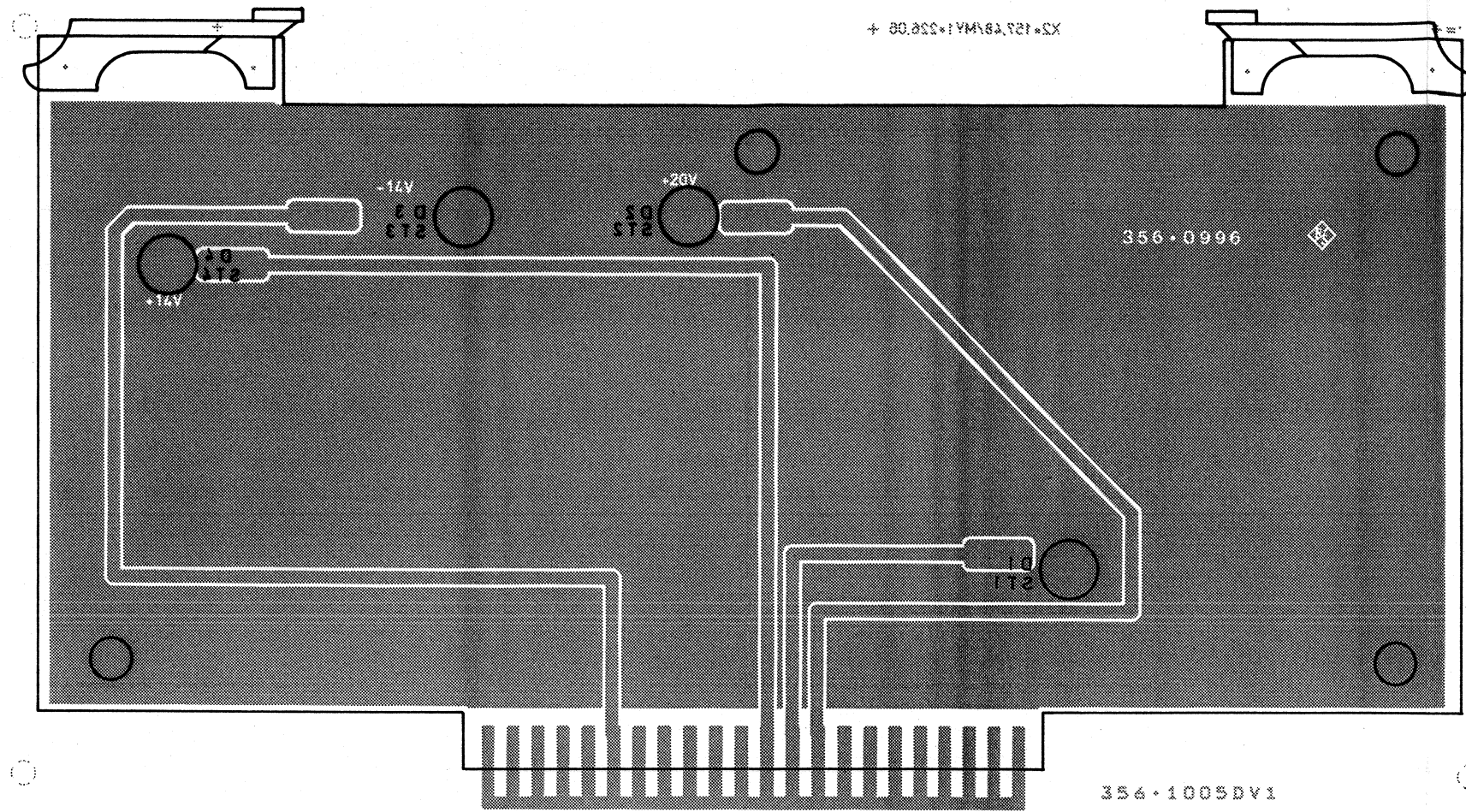

Ansicht und Leitungsführung Lötseite  
View of tracks on solder side



				Maße ohne Toleranzangabe		Maßstab 1:1	
						Halbzeug, Werkstoff	
				1KGA	Tag	Name	Benennung
				Bearb	12.83	GS	Zuführ. Phasenregelung FEED PHASE CONTROL
				Gepr			Z
				Norm			
				<b>ROHDE &amp; SCHWARZ</b>		Zeichn.-Nr.	
						356.0996	
				zu Gerät SMPC		reg. V 355.9519 V erste Z 356.0980	
And. Zust.	Anderungs-Mittelung	Tag	Name			Blatt Nr. 3	
						v. Bl.	





**ROHDE & SCHWARZ**

SERVICE INSTRUCTIONS FOR  
Amplitude Modulator + ALC  
300.7414.02 (Y12)

# Table of Contents

		Page
<u>5</u>	<u>Service Instructions for</u> <u>Amplitude Modulator + ALC 300.7414.02 (Y12)</u> .....	5.1
5.1	Circuit Description .....	5.1
5.2	Checking and Adjustment Procedures .....	5.2
5.2.1	Checking the Reference Modulator .....	5.2
5.2.2	Checking the Electronic Attenuator .....	5.2
5.2.3	Adjustment .....	5.3
5.3	Troubleshooting .....	5.3
5.3.1	Reference Modulator .....	5.3
5.3.2	Interfaces .....	5.4

Parts list  
Circuit diagram  
Components location plans

### 5.1 Circuit Description

(See circuit diagram 300.7414.02 S and Fig. 5-2)

The high-precision reference modulator (B7, analog multiplier) of Y12 produces a 10-MHz signal the envelope of which represents the desired output signal characteristic. It is controlled by subassembly Y3. A multiplying D/A converter provides the fine resolution of the amplitude setting. Equivalent rectifiers in the output stage III (Y15) for this reference signal and the RF to be controlled eliminate any effects from linearity and temperature drifts. The rectified voltages are applied as nominal and actual values via BU161 and BU162 to the control amplifier B50 which controls the PIN modulator. The time constant can be switched over to slow down the control action in unmodulated operation and with modulating frequencies up to 3 kHz (internal). If the control voltage assumes extreme values, B52 sends an alarm signal to the CPU Y1 (L = alarm).

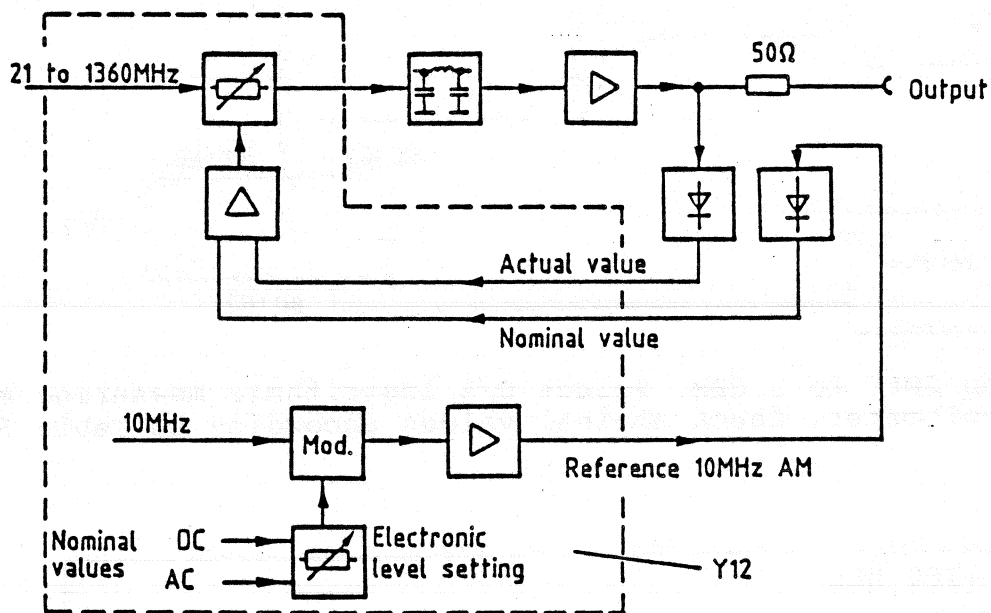

Fig. 5-1 Functional diagram of AM/ALC control circuit



## 5.2 Checking and Adjustment Procedures

### 5.2.1 Checking the Reference Modulator

Feed 10-MHz signal with level of  $6 \pm 1$  dBm into BU165. Connect power meter (range 20 dBm) to BU163. Measure level at 13 dBm setting ( $\approx 17.4$  dBm). Check that the level decreases by  $3 \pm 0.1$  dB at a setting of 10 dBm, by  $4.9 \pm 0.1$  dB at a setting of 8.1 dBm, by  $10 \pm 0.2$  dB at a setting of  $-137$  dBm and by  $16 \pm 0.3$  dB at a setting of  $-143$  dBm.

### 5.2.2 Checking the Electronic Attenuator

Connect MP50 to BU161.  
Feed DC voltage of  $-4$  to  $+10$  V into BU162.

Test setup:

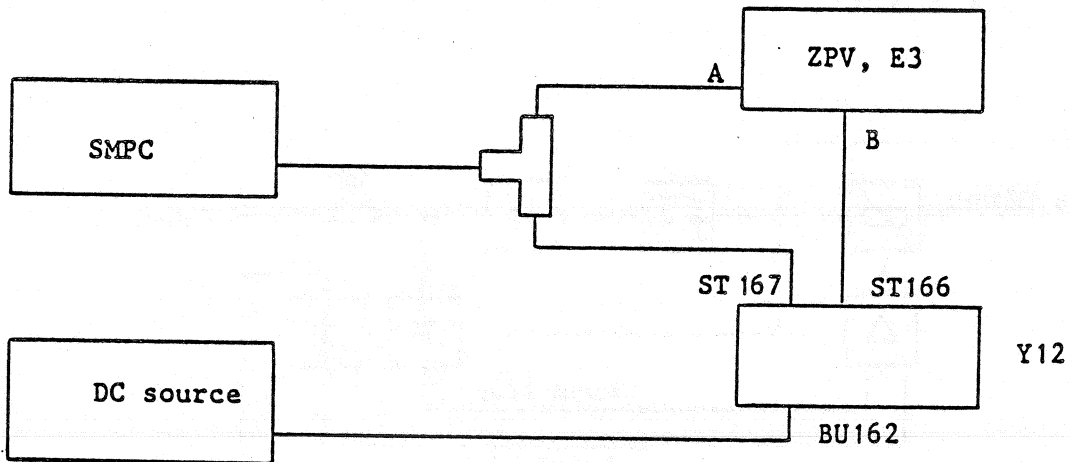

Set level on SMPC to 3 dBm. Select B/A logarithmic measuring mode on vector voltmeter. Check nominal values according to Table 5-1.

Table 5-1

Frequency 1360 MHz							
BU162	$+10 \pm 1$	$-0.4 \pm 0.1$	$-2 \pm 0.05$	$-2.7 \pm 0.05$	$-3 \pm 0.05$	$-4 \pm 0.2$	VDC
B/A	$> 5$	$0 \pm 2$	$-10 \pm 3$	$-20 \pm 5$	$-30 \pm 7$	$< -50$	dB

Frequency 22 MHz							
BU162	$+10 \pm 1$	$-1 \pm 0.1$	$-2.5 \pm 0.05$	$-2.95 \pm 0.05$	$-3.1 \pm 0.05$	$-4 \pm 0.2$	VDC
B/A.	$> 7$	$0 \pm 2$	$-10 \pm 3$	$-20 \pm 5$	$-30 \pm 7$	$< -55$	dB

### 5.2.3 Adjustment

For adjustment see section 4.3.

### 5.3 Troubleshooting

(For signature analysis see CPU Y1)

#### 5.3.1 Reference Modulator

DC test points

MP1	4.21	±0.04	V		
MP2	-4.21	±0.05	V	with	13 dBm
	-2.39	±0.05	V	with	8.1 dBm
	-0.67	±0.05	V	with	-143 dBm
MP3	7.5	±0.1	V		
MP4	13.4	±0.2	V		
Coll. T20	9.8	±0.3	V		
MP21	7	±0.5	V		

### 5.3.2 Interfaces

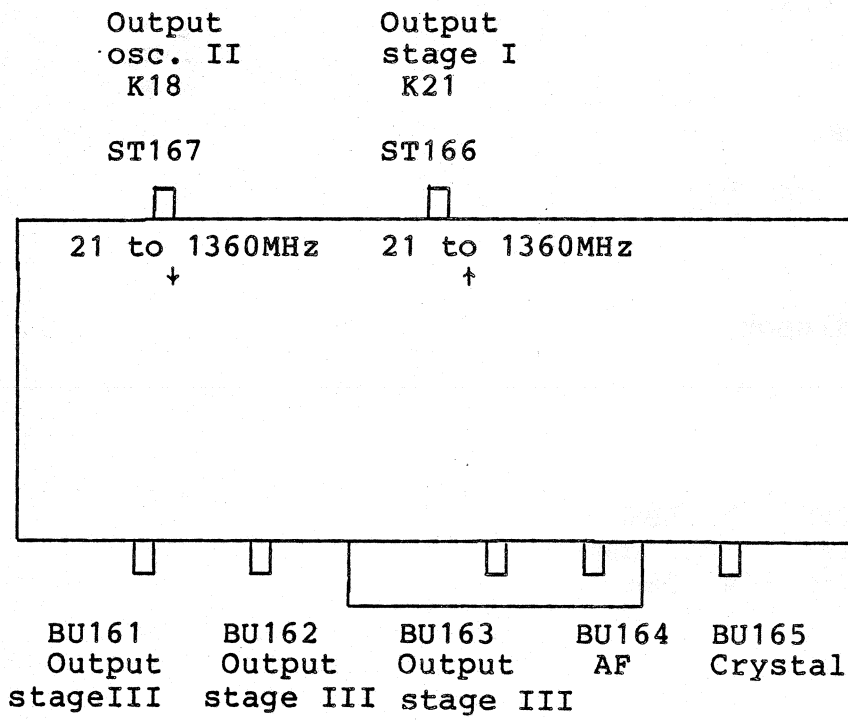

ST/BU	161	162	163	164
f	DC + AF	DC + AF	10 MHz	DC to 50 kHz
Level	0.2 to 2.5 V	0.2 to 2.5 V	to 2 V <sub>rms</sub>	to 3 V <sub>rms</sub>
Z	2.2 kΩ	high impedance	15 Ω	10 kΩ
AC-DC	DC	DC	AC	DC
Shape of curve	DC + AF	DC + AF	sinusoidal	sinusoidal

ST/BU	165	166	167
f	10 MHz	21 to 1360 MHz	21 to 1360 MHz
Level	1.4 ± 0.2 V <sub>SS</sub>	3 to 11 dBm	9 to 13 dBm
Z	56 Ω	50 Ω	50 Ω
AC-DC	AC	AC	AC
Shape of curve	rectangular	rectangular	rectangular

## Digital interface

2 strobes, data: nominal level with 12-bit resolution  
time constant switchover

	D7	6	5	4	3	2	1	0	
Strobe 1	x	a	MSB	-	-	-	-	-	Data for
Strobe 2	x	x	-	-	-	-	-	LSB	D/A converter

a: 1 corresponding to mod. slow, AM off  
0 corresponding to mod. fast, AM on

The binary number 4095 (all bits at "1") corresponds to the maximum level of 1000 mV into 50  $\Omega$  (mechanical attenuator at 0 dB).

Other levels are expressed by

$$P = \frac{\text{level in mV}}{1000} \cdot 4095.$$

The binary data for P are sent from the CPU (Y1) to Y12 in two 6-bit words.

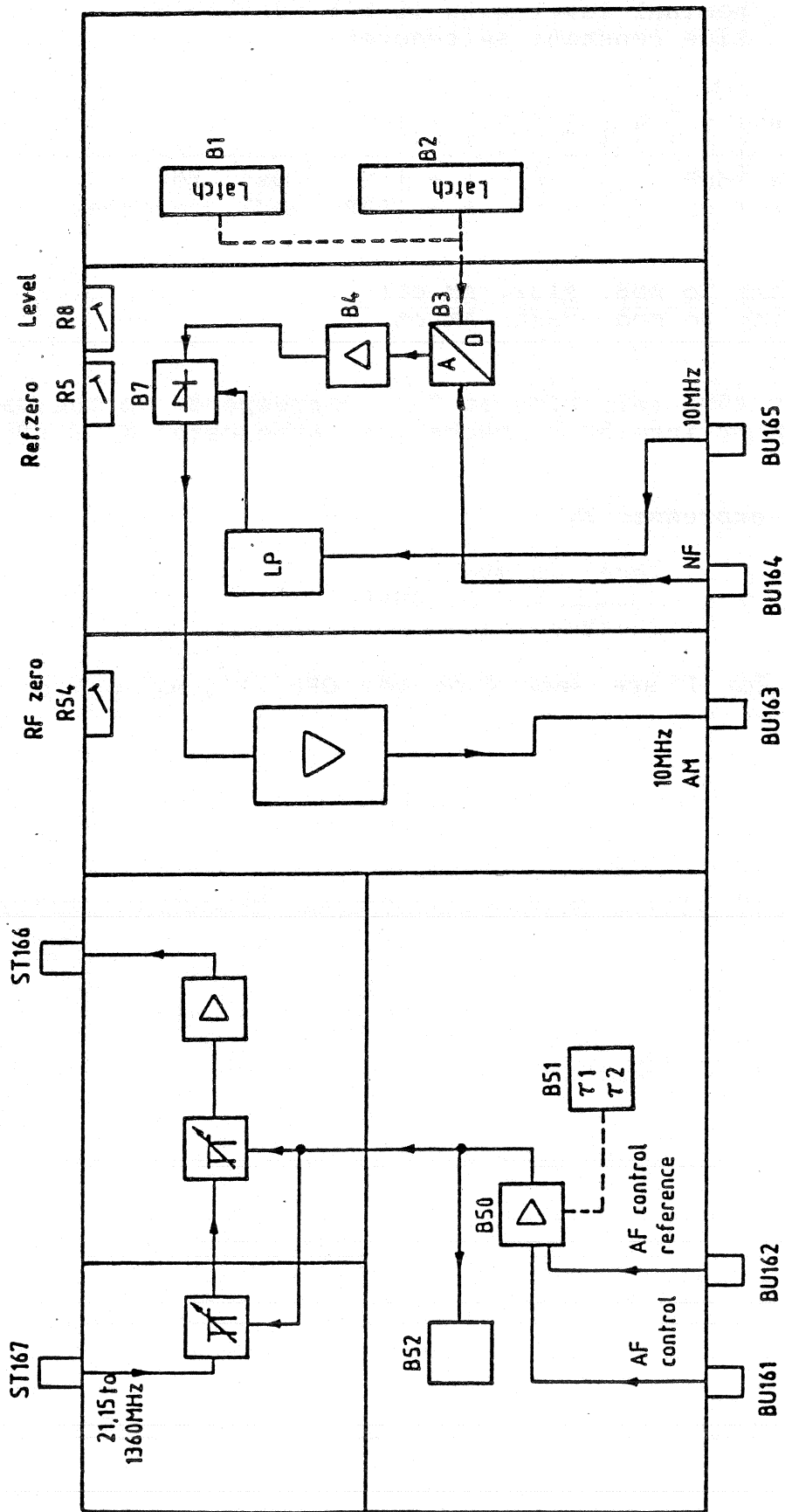

Fig. 5-2 Block diagram of amplitude modulator + ALC



ROHDE & SCHWARZ  
MÜNCHEN

Schalteillisten  
Stromläufe  
Bestückungspläne  
Parts lists  
Circuit diagrams  
Components plans



ROHDE & SCHWARZ

ÄZ Datum  
Date 23 1185

Schaltteilliste für  
Parts list for  
ZE AM-MODULATOR + ALC

Sachnummer  
Stock No. 300.7414.01 SA

Blatt  
Page 1

Kennzeichen Component No.	Benennung/Beschreibung Designation	Sachnummer Stock No.	enthalten in contained in
B1	BL SN74LS174N 6/D-FLIPFL. IC FLIP-FLOP SN74LS174N TEXAS SN74LS174N	BL 266.7970	300.5434.01
B2	BL SN74LS273N 8BIT-D-REG. 8BIT-D-REGISTER TEXAS SN74LS273N	BL 214.8998	300.5434.01
B3	BJ AD7531KD 12B.D/A-CONV D/A-CONVERTER ANALOG-DEV AD7531KD	BJ 300.9369	300.5434.01
B4	BO LF156AH BIFET OPAMP OPERATIONAL AMPLIFIER PMI PM156AJ	BO 296.8380	300.5434.01
B5	BO AD581J 10V 10MA VREF NUR VAR : 03 VOLTAGE REFERENCE ANALOG-DEV AD581J FUER VAR 03/FOR MOD.03	BO 300.6347	300.5434.01
B6	BO LM210H VOLT.FOLLOW NUR VAR : 03 VOLTAGE FOLLOWER NSC LM210H FUER VAR 03/FOR MOD.03	BO 300.9398	300.5434.01
B7	BO LM1596 MOD/DEMOM MODULATOR/DEMOMULATOR NSC LM1596H	BO 417.0419	300.5434.01
B50	BO LF156AH BIFET OPAMP OPERATIONAL AMPLIFIER PMI PM156AJ	BO 296.8380	300.5434.01
B51	BJ DG300BP 2X ANALOGSCH ANALOG SWITCH SILICONIX DG300BP	BJ 300.9375	300.5434.01
B52	BO TCA965 FENSTER-DISKIM DISCRIMINATOR SIEMENS TCA965	BO 279.2213	300.5434.01
BU1	FP BUCHSE VERTIKAL P.V.1P SOCKET BERG 75377-001	FP 278.5577	300.5434.01
BU2	FP BUCHSE VERTIKAL P.V.1P SOCKET BERG 75377-001	FP 278.5577	300.5434.01
BU3	FP BUCHSE VERTIKAL P.V.1P SOCKET BERG 75377-001	FP 278.5577	300.5434.01
BU4	FP BUCHSE VERTIKAL P.V.1P SOCKET BERG 75377-001	FP 278.5577	300.5434.01
BU5	FP BUCHSE VERTIKAL P.V.1P SOCKET BERG 75377-001	FP 278.5577	300.5434.01
BU6	FP BUCHSE VERTIKAL P.V.1P SOCKET BERG 75377-001	FP 278.5577	300.5434.01
BU7	FP BUCHSE VERTIKAL P.V.1P SOCKET BERG 75377-001	FP 278.5577	300.5434.01

300.7414.01 SA BL 1+

Für diese Unterlage behalten wir  
uns alle Rechte vor



ROHDE & SCHWARZ

AZ Datum Date  
23 1185

Schaltteilliste für  
Parts list for  
ZE AM-MODULATOR + ALC

Sachnummer  
Stock No.  
300.7414.01 SA

Blatt  
Page  
2

Kennzeichen Component No.	Benennung/Beschreibung Designation	Sachnummer Stock No.	enthalten in contained in
BU8	FP BUCHSE VERTIKAL P.V.1P SOCKET BERG 75377-001	FP 278.5577	300.5434.01
BU9	FP BUCHSE VERTIKAL P.V.1P SOCKET BERG 75377-001	FP 278.5577	300.5434.01
BU10	FP BUCHSE VERTIKAL P.V.1P SOCKET BERG 75377-001	FP 278.5577	300.5434.01
BU11	FP BUCHSE VERTIKAL P.V.1P SOCKET BERG 75377-001	FP 278.5577	300.5434.01
BU12	FP BUCHSE VERTIKAL P.V.1P SOCKET BERG 75377-001	FP 278.5577	300.5434.01
BU13	FP BUCHSE VERTIKAL P.V.1P SOCKET BERG 75377-001	FP 278.5577	300.5434.01
BU161	FJ EINBAUBUCHSE SYST.SMS FIXED SOCKET RADIALL R.299 012	300.6876	
BIS/TO BU165			
C1	CC 10NF-20+50%7X8R6000 CAPACITOR VALVO 2222 63051 64051103	CC 087.7525	300.5434.01
C2	CC 10NF-20+50%7X8R6000 CAPACITOR VALVO 2222 63051 64051103	CC 087.7525	300.5434.01
C3	CC 10NF-20+50%7X8R6000 CAPACITOR VALVO 2222 63051 64051103	CC 087.7525	300.5434.01
C4	CC 10NF-20+50%7X8R6000 CAPACITOR VALVO 2222 63051 64051103	CC 087.7525	300.5434.01
C5	CC 10NF-20+50%7X8R6000 NUR VAR : 03 CAPACITOR VALVO 2222 63051 64051103	CC 087.7525	300.5434.01
C6	FUER VAR 03/FOR MOD.03 CC 560PF+-10%3X4R2000 CAPACITOR VALVO 2222 63051 561	CC 087.7002	300.5434.01
C7	CC 820PF+-10%4X5R2000 CAPACITOR VALVO 2222 63051 821	CC 087.7025	300.5434.01
C8	CC 560PF+-10%3X4R2000 CAPACITOR VALVO 2222 63051 561	CC 087.7002	300.5434.01
C9	CE 47UF -10+100%16V 9X13 NUR VAR : 03 ELECTROLYTIC CAPACITOR ROEDERST ELKO EK47/16 FUER VAR 03/FOR MOD.03	022.7543	300.5434.01

300.7414.01 SA BL 2+



**ROHDE & SCHWARZ**

ÄZ	Datum
23	1185

 Schalteilliste für  
 Parts list for  
**ZE AM-MODULATOR + ALC**

Sachnummer	Blatt
Stock No.	Page
300.7414.01 SA	3

Sachnummer	Blatt
Stock No.	Page
300.7414.01 SA	3

Kennzeichen Component No.	Benennung/Beschreibung Designation	Sachnummer Stock No.	enthalten in contained in
C10	CC 47PF+-2%3X4N750 CAPACITOR VALVO 2222 678 58479	CC 087.6864	300.5434.01
C11	CC 47PF+-2%5X6NPO CAPACITOR VALVO 2222 678 10479	CC 087.6506	300.5434.01
C12	CC 56PF+-2%5X6NPO CAPACITOR VALVO 2222 678 10569	CC 087.6512	300.5434.01
C13	CC 18PF+-2%3X4NPO CAPACITOR VALVO 2222 678 10189	CC 087.6458	300.5434.01
C14	CC 10NF-20+50%7X8R6000 CAPACITOR VALVO 2222 63051 64051103	CC 087.7525	300.5434.01
C16	CC 10NF-20+50%7X8R6000 CAPACITOR VALVO 2222 63051 64051103	CC 087.7525	300.5434.01
C20	CC 1NF+-10%63V K2000 CERAMIC CAPACITOR VALVO 2222 63051 102	CC 022.0784	300.5434.01
C21	CC 4,7NF+-10%6X9R2000 CAPACITOR VALVO 2222 63051 472	CC 087.7102	300.5434.01
C23	CC 4,7NF+-10%6X9R2000 CAPACITOR VALVO 2222 63051 472	CC 087.7102	300.5434.01
C24	CC 4,7NF+-10%6X9R2000 CAPACITOR VALVO 2222 63051 472	CC 087.7102	300.5434.01
C25	CC 4,7NF+-10%6X9R2000 CAPACITOR VALVO 2222 63051 472	CC 087.7102	300.5434.01
C26	CC 4,7NF+-10%6X9R2000 CAPACITOR VALVO 2222 63051 472	CC 087.7102	300.5434.01
C27	CC 3,3PF+-0,25PF4X5P100 CAPACITOR VALVO 2222 678 03338	CC 087.6235	300.5434.01
C28	CC 4,7NF+-10%6X9R2000 CAPACITOR VALVO 2222 63051 472	CC 087.7102	300.5434.01
C29	CC 10NF-20+50%7X8R6000 CAPACITOR VALVO 2222 63051 64051103	CC 087.7525	300.5434.01
C30	CC 10NF-20+50%7X8R6000 CAPACITOR VALVO 2222 63051 64051103	CC 087.7525	300.5434.01
C31	CE 2,2UF-10+50% 63V 9X13 ELECTROLYTIC CAPACITOR ROEDERST ELKO EK 2/63	CE 022.7637	300.5434.01
C32	CC 10NF-20+50%7X8R6000 CAPACITOR VALVO 2222 63051 64051103	CC 087.7525	300.5434.01
C50	CC 220PF+-2%6X7N750 CAPACITOR VALVO 2222 678 58221	CC 087.6941	300.5434.01

300.7414.01 SA BL 3+

Für diese Unterlage behalten wir  
uns alle Rechte vor

**ROHDE & SCHWARZ**

ÄZ

Datum  
DateSchaltteilliste für  
Parts list for  
ZE AM-MODULATOR + ALCSachnummer  
Stock No.Blatt  
Page

23

1185

300.7414.01 SA

4

Kennzeichen Component No.	Benennung/Beschreibung Designation	Sachnummer Stock No.	enthalten in contained in
C51	CC 470PF+-10%3X4R2000 CAPACITOR VALVO 2222 63051 471	CC 087.6993	300.5434.01
C52	CC 2,2NF+-10%5X6R2000 CAPACITOR VALVO 2222 63051 222	CC 087.7060	300.5434.01
C54	CC 10NF-20+50%7X8R6000 CAPACITOR VALVO 2222 63051 64051103	CC 087.7525	300.5434.01
C55	CC 100NF+-10%50V5K1200VIE CAPACITOR UNION CARB M39014/01-1433	CC 084.5350	300.5434.01
C56	CC 1,5NF+-10%4X5R2000 CAPACITOR VALVO 2222 63051 152	CC 087.7048	300.5434.01
C58	CC 10NF-20+50%7X8R6000 CAPACITOR VALVO 2222 63051 64051103	CC 087.7525	300.5434.01
C59	CC 10NF-20+50%7X8R6000 CAPACITOR VALVO 2222 63051 64051103	CC 087.7525	300.5434.01
C61	CC 180PF+-10% R700 TRAP CAPACITOR DRALORIC TRE7LOE180/10R700	CC 086.7496	300.5434.01
C62	CC 180PF+-10% R700 TRAP CAPACITOR DRALORIC TRE7LOE180/10R700	CC 086.7496	300.5434.01
C63	CC 180PF+-10% R700 TRAP CAPACITOR DRALORIC TRE7LOE180/10R700	CC 086.7496	300.5434.01
C64	CC 180PF+-10% R700 TRAP CAPACITOR DRALORIC TRE7LOE180/10R700	CC 086.7496	300.5434.01
C65	CC 680PF+-10%100V3K1200 C CAPACITOR VITRAMON VJ1005Y681KFB	CC 082.3209	300.5434.01
C66	CC 1NF+80-20%R4000 TRAP CERAMIC CAPACITOR DRALORIC TRE7LOE1000/2080%R40	CC 086.7515	300.5434.01
C67	CC 1NF+80-20%R4000 TRAP CERAMIC CAPACITOR DRALORIC TRE7LOE1000/2080%R40	CC 086.7515	300.5434.01
C68	CC 680PF+-10%100V3K1200 C CAPACITOR VITRAMON VJ1005Y681KFB	CC 082.3209	300.5434.01
C69	CC 4,7PF+-0,5PF100V3NPO C CAPACITOR VITRAMON VJ1005A4R7DFB	CC 082.2977	300.5434.01
C70	CC 10NF+-10% 50V3K1200 CH CAPACITOR VITRAMON VJ1005Y103KFB	CC 082.3344	300.5434.01
C71	CC 4,7NF+-20%100V3K1200 C CERAMIC CAPACITOR VITRAMON VJ1005Y472MFB	CC 022.4450	300.5434.01
C72	CC 10NF-20+50%7X8R6000 CAPACITOR VALVO 2222 63051 64051103	CC 087.7525	300.5434.01

300.7414.01 SA BL 4+



ROHDE & SCHWARZ

ÄZ Datum  
Date  
23 1185

Schaltteilliste für  
Parts list for  
ZE AM-MODULATOR + ALC

Sachnummer  
Stock No.  
300.7414.01 SA

Blatt  
Page  
5

Kennzeichen Component No.	Benennung/Beschreibung Designation	Sachnummer Stock No.	enthalt in contained in
C73	CC 10NF-20+50%7X8R6000 CAPACITOR VALVO 2222 63051 64051103	CC 087.7525	300.5434.01
C80	CE 100UF-10+50% 25V 13X13 ELECTROLYTIC CAPACITOR ROEDERST ELKOEK100/25	CE 208.4007	300.5434.01
C81	CE 100UF-10+50% 25V 13X13 ELECTROLYTIC CAPACITOR ROEDERST ELKOEK100/25	CE 208.4007	300.5434.01
C520	CC 10NF-20+50%7X8R6000 CAPACITOR VALVO 2222 63051 64051103	CC 087.7525	300.5434.01
C590	CE 22UF -10+100%40V 9X13 ELECTROLYTIC CAPACITOR SIEMENS B41316-A7226-V	022.7572	300.5434.01
D1	LD 35DB/200M-10GHZ PI-FIL CHOKE ERIE 1214-038	LD 300.6818	300.5457
BIS/TO D13			
GL20	AD 1N4448 75V 0,15A UDI DIODE VALVO 1N4448	AD 012.0700	300.5434.01
GL21	AD 1N4448 75V 0,15A UDI DIODE VALVO 1N4448	AD 012.0700	300.5434.01
GL22	AD 1N4448 75V 0,15A UDI DIODE VALVO 1N4448	AD 012.0700	300.5434.01
GL60	BO TDA1053 PIN-D.PI-GLIED DIODE ARRAY INTERMETAL TDA1053A	302.5477	300.5434.01
GL61	BO TDA1053 PIN-D.PI-GLIED DIODE ARRAY INTERMETAL TDA1053A	302.5477	300.5434.01
L10	LD 180 UH10%17,00HMO,057A CHOKE DELEVAN DROSSEL1025-74	LD 067.3130	300.5434.01
L11	LD 22,0UH10%3,300HMO,114A CHOKE DELEVAN DROSSEL1025-52	LD 067.3024	300.5434.01
L12	LD 15,0UH10%2,800HMO,157A CHOKE DELEVAN DROSSEL1025-48	LD 067.3001	300.5434.01
L13	LD 0,82UH10%0,850HMO,420A CHOKE DELEVAN DROSSEL1025-18	LD 067.2857	300.5434.01
L14	LD 0,82UH10%0,850HMO,420A CHOKE DELEVAN DROSSEL1025-18	LD 067.2857	300.5434.01
L20	LD 47,0UH10%4,500HMO,110A CHOKE DELEVAN DROSSEL1025-60	LD 067.3060	300.5434.01

300.7414.01 SA BL 5+

Für diese Unterlage behalten wir  
uns alle Rechte vor

**ROHDE & SCHWARZ**

ÄZ	Datum
23	1185

 Schaltteilliste für  
 Parts list for  
 ZE AM-MODULATOR + ALC

Sachnummer	Stock No.
300.7414.01	SA

Blatt	Page
	6

Kennzeichen Component No.	Benennung/Beschreibung Designation	Sachnummer Stock No.	enthalten in contained in
L21	LD 15,0UH10%2,800HMO,157A CHOKE DELEVAN DROSSEL1025-48	LD 067.3001	300.5434.01
L50	LD 120 UH 10% 54,5 MIA CHOKE DELEVAN	LD 092.3401	300.5434.01
L51	LD 120 UH 10% 54,5 MIA CHOKE DELEVAN	LD 092.3401	300.5434.01
L52	LD 68,0UH10%6,700HMO,092A CHOKE DELEVAN DROSSEL1025-64	LD 067.3082	300.5434.01
L60	LD 47,0UH10%4,500HMO,110A CHOKE DELEVAN DROSSEL1025-60	LD 067.3060	300.5434.01
L61	LD SPULE COIL	300.9400	300.5434.01
L62	ENTHALTEN IN/INCLUDED IN LEITERPLATTE/PCB		300.5434.01
L63	LD 47,0UH10%4,500HMO,110A CHOKE DELEVAN DROSSEL1025-60	LD 067.3060	300.5434.01
L70	LD 27,0UH10%3,500HMO,140A CHOKE DELEVAN DROSSEL1025-54	LD 067.3030	300.5434.01
L80	LD 2,70UH10%0,550HMO,355A CHOKE DELEVAN DROSSEL1025-30	LD 067.2911	300.5434.01
MP1	VL WIRE-WRAP PIN BERG NR. 75 403-001	VL 088.4507	300.5434.01
BIS/TO MP4 MP20	VL WIRE-WRAP PIN BERG NR. 75 403-001	VL 088.4507	300.5434.01
MP21	VL WIRE-WRAP PIN BERG NR. 75 403-001	VL 088.4507	300.5434.01
MP50	VL WIRE-WRAP PIN BERG NR. 75 403-001	VL 088.4507	300.5434.01
R1	RL 0,35W15,0KOHM+-0,1%T25 NUR VAR : 03 RESISTOR DRALORIC SMA0207/15,0K-B-E FUER VAR 03/FOR MOD.03	RL 084.3406	300.5434.01
R2	RL 0,35W11,0KOHM+-0,1%T25 NUR VAR : 03 RESISTOR DRALORIC SMA0207/11K-B-E FUER VAR 03/FOR MOD.03	RL 084.3141	300.5434.01
R3	RL 0,35W 100 OHM+-1%TK50 DEPOS.-CARBON RESISTOR DRALORIC SMA0207/100/HM-F-D	RL 082.6543	300.5434.01
R4	RL 0,35W 4,75KOHM+-1%TK50 RESISTOR DRALORIC SMA0207/4,75K-F-D	RL 083.1097	300.5434.01

300.7414.01 SA BL 6+



RONDE & SCHWARZ

ÄZ Datum  
Date  
23 1185

Schaltteilleiste für  
Parts list for  
ZE AM-MODULATOR + ALC

Sachnummer  
Stock No.  
300.7414.01 SA

Blatt  
Page  
7

Kennzeichen Component No.	Benennung/Beschreibung Designation	Sachnummer Stock No.	enthalten in contained in
R5	RS 0,5W100KOHM+-10%10X10X CERMET POTENTIOMETER T BOURNS 3386X-1-104	RS 087.7683	300.5434.01
R6	RL 0,35W 4,75KOHM+-1%TK50 RESISTOR DRALORIC SMA0207/4,75K-F-D	RL 083.1097	300.5434.01
R7	RL 0,35W 4,75KOHM+-1%TK50 RESISTOR DRALORIC SMA0207/4,75K-F-D	RL 083.1097	300.5434.01
R8	RS 0,5W5KOHM+-10%10X10X5 CERMET POTENTIOMETER BOURNS 3386X-1-502	RS 247.7978	300.5434.01
R9	RL 0,35W 12,1KOHM+-1%TK50 RESISTOR DRALORIC SMA0207/12,1K-F-D	RL 083.1351	300.5434.01
R10	RL 0,35W 47,5 OHM+-1%TK50 RESISTOR DRALORIC SMA0207/47,5OHM-F-D	RL 082.9507	300.5434.01
R12	RL 0,35W 39,2 OHM+-1%TK50 RESISTOR DRALORIC SMA0207/39,2OHM-F-D	RL 082.9420	300.5434.01
R13	RL 0,35W 6,81KOHM+-1%TK50 RESISTOR DRALORIC SMA 0207/6,81K-F-C	RL 082.2560	300.5434.01
R14	RL 0,35W 8,25KOHM+-1%TK50 RESISTOR DRALORIC SMA0207/8,25K-F-D	RL 083.1239	300.5434.01
R15	RL 0,35W 1KOHM+-1%TK50 RESISTOR DRALORIC SMA0207/1K-F-C	RL 082.2160	300.5434.01
R16	RL 0,35W 33,2 OHM+-1%TK50 RESISTOR DRALORIC SMA0207/33,2OHM-F-D	RL 082.9359	300.5434.01
R20	RL 0,35W 392 OHM+-1%TK50 RESISTOR DRALORIC SMA0207/392K-F-C	RL 082.2183	300.5434.01
R21	RL 0,35W 681 OHM+-1%TK50 RESISTOR DRALORIC SMA0207/681OHM-F-D	RL 083.0490	300.5434.01
R22	RL 0,35W 681 OHM+-1%TK50 RESISTOR DRALORIC SMA0207/681OHM-F-D	RL 083.0490	300.5434.01
R23	RL 0,35W 681 OHM+-1%TK50 RESISTOR DRALORIC SMA0207/681OHM-F-D	RL 083.0490	300.5434.01
R24	RL 0,35W 182 OHM+-1%TK50 RESISTOR DRALORIC SMA0207/182OHM-F-D	RL 083.0010	300.5434.01
R25	RL 0,35W 182 OHM+-1%TK50 RESISTOR DRALORIC SMA0207/182OHM-F-D	RL 083.0010	300.5434.01
R26	RL 0,35W 274 OHM+-1%TK50 RESISTOR DRALORIC SMA0207/274OHM-F-D	RL 083.0178	300.5434.01
R27	RL 0,35W 3,32KOHM+-1%TK50 RESISTOR DRALORIC SMA0207/3,32K-F-D	RL 083.0990	300.5434.01

300.7414.01 SA BL 7+

Für diese Unterlage behalten wir  
uns alle Rechte vor

Kennzeichen Component No.	Benennung/Beschreibung Designation	Sachnummer Stock No.	enthalten in contained in
R28	RL 0,35W 15,0KOHM+-1%TK50 RESISTOR DRALORIC SMA0207/15K-F-D	RL 083.1400	300.5434.01
R29	RL 0,35W 15,0KOHM+-1%TK50 RESISTOR DRALORIC SMA0207/15K-F-D	RL 083.1400	300.5434.01
R30	RL 0,35W 3,32KOHM+-1%TK50 RESISTOR DRALORIC SMA0207/3,32K-F-D	RL 083.0990	300.5434.01
R31	RL 0,35W 68,1 OHM+-1%TK50 RESISTOR DRALORIC SMA0207/68,10HM-F-D	RL 082.9636	300.5434.01
R32	RL 0,35W 68,1 OHM+-1%TK50 RESISTOR DRALORIC SMA0207/68,10HM-F-D	RL 082.9636	300.5434.01
R33	RL 0,35W 825 OHM+-1%TK50 RESISTOR DRALORIC SMA0207/825OHM-F-C	RL 082.2502	300.5434.01
R34	RL 0,35W 39,2 OHM+-1%TK50 RESISTOR DRALORIC SMA0207/39,20HM-F-D	RL 082.9420	300.5434.01
R35	RL 0,35W 10,0 OHM+-1%TK50 RESISTOR DRALORIC SMA0207/100HM-F-D	RL 082.8852	300.5434.01
R50	RL 0,35W 12,1KOHM+-1%TK50 RESISTOR DRALORIC SMA0207/12,1K-F-D	RL 083.1351	300.5434.01
R51	RL 0,35W 2,00KOHM+-1%TK50 RESISTOR DRALORIC SMA0207/2,00K-F-D	RL 083.0826	300.5434.01
R54	RS 0,5W100KOHM+-10%10X10X CERMET POTENTIOMETER T BOURNS 3386X-1-104	RS 087.7683	300.5434.01
R57	RL 0,35W 150 OHM+-1%TK50 RESISTOR DRALORIC SMA0207/150OHM-F-D	RL 082.9942	300.5434.01
R60	RL 0,35W 5,62KOHM+-1%TK50 RESISTOR DRALORIC SMA0207/5,62K-F-C	RL 082.2190	300.5434.01
R61	RL 0,35W 12,1KOHM+-1%TK50 RESISTOR DRALORIC SMA0207/12,1K-F-D	RL 083.1351	300.5434.01
R62	RL 0,35W 15,0KOHM+-1%TK50 RESISTOR DRALORIC SMA0207/15K-F-D	RL 083.1400	300.5434.01
R63	RL 0,35W 15,0KOHM+-1%TK50 RESISTOR DRALORIC SMA0207/15K-F-D	RL 083.1400	300.5434.01
R64	RL 0,35W 182 OHM+-1%TK50 RESISTOR DRALORIC SMA0207/182OHM-F-D	RL 083.0010	300.5434.01
R65	RL 0,35W 15,0KOHM+-1%TK50 RESISTOR DRALORIC SMA0207/15K-F-D	RL 083.1400	300.5434.01
R66	RL 0,35W 15,0KOHM+-1%TK50 RESISTOR DRALORIC SMA0207/15K-F-D	RL 083.1400	300.5434.01



ROHDE & SCHWARZ

ÄZ Datum  
Date  
23 1185

Schaltteilliste für  
Parts list for  
ZE AM-MODULATOR + ALC

Sachnummer  
Stock No.

300.7414.01 SA

Blatt  
Page

9

Kennzeichen Component No.	Benennung/Beschreibung Designation	Sachnummer Stock No.	enthalten in contained in
R67	RL 0,35W 5,62KOHM+-1%TK50 RESISTOR DRALORIC SMA0207/5,62K-F-C	RL 082.2190	300.5434.01
R68	RL 0,35W 12,1KOHM+-1%TK50 RESISTOR DRALORIC SMA0207/12,1K-F-D	RL 083.1351	300.5434.01
R69	RG 0,125W 33 OHM+-1% CHIP CHIP RESISTOR MSI WA-4 330HM 1% PG-T	337.8214	300.5434.01
R70	RL 0,35W 182 OHM+-1%TK50 RESISTOR DRALORIC SMA0207/182OHM-F-D	RL 083.0010	300.5434.01
R71	RL 0,35W 150 OHM+-1%TK50 RESISTOR DRALORIC SMA0207/150OHM-F-D	RL 082.9942	300.5434.01
R72	RL 0,35W 1,50KOHM+-1%TK50 RESISTOR DRALORIC SMA0207/1,50K-F-D	RL 083.0732	300.5434.01
R73	RL 0,35W 47,5KOHM+-1%TK50 RESISTOR DRALORIC SMA/207/47,5K-F-C	RL 083.1800	300.5434.01
R74	RL 0,35W 68,1KOHM+-1%TK50 RESISTOR DRALORIC SMA 0207/68,1K-F-C	RL 082.2602	300.5434.01
R520	RL 0,35W 56,2KOHM+-1%TK50 RESISTOR DRALORIC SMA0207/56,2K-F-C	RL 082.2231	300.5434.01
R521	RL 0,35W 39,2KOHM+-1%TK50 RESISTOR DRALORIC SMA/207/39,2K-F-C	RL 083.1745	300.5434.01
R522	RL 0,35W 47,5KOHM+-1%TK50 RESISTOR DRALORIC SMA/207/47,5K-F-C	RL 083.1800	300.5434.01
R523	RL 0,35W 33,2KOHM+-1%TK50 RESISTOR DRALORIC SMA0207/33,2K-F-C	RL 083.1674	300.5434.01
R524	RL 0,35W 1KOHM+-1%TK50 RESISTOR DRALORIC SMA0207/1K-F-C	RL 082.2160	300.5434.01
R525	RL 0,35W 33,2KOHM+-1%TK50 RESISTOR DRALORIC SMA0207/33,2K-F-C	RL 083.1674	300.5434.01
R526	RL 0,35W 1,50KOHM+-1%TK50 RESISTOR DRALORIC SMA0207/1,50K-F-D	RL 083.0732	300.5434.01
ST1	FP EINZELKONTAKTSTIFT SINGLE-CONTACT PIN ULMIC R&S.ZCHNG.300.8804	300.8804	300.5457
BIS/TO ST13 ST160	ENTHALTEN IN/INCLUDED IN LEITERPLATTE/PCB		300.5457
ST166	FJ EINBAUWINKELST. SMC ANGLE CONNECTOR RADIALL R 112 669	FJ 249.9684	300.5434.01

300.7414.01 SA BL 9+

Für diese Unterlage behalten wir  
uns alle Rechte vor



ROHDE & SCHWARZ

ÄZ Datum  
Date  
23 1185

Schaltteilliste für  
Parts list for  
ZE AM-MODULATOR + ALC

Sachnummer  
Stock No.

300.7414.01 SA

Blatt  
Page

10

Kennzeichen Component No.	Benennung/Beschreibung Designation	Sachnummer Stock No.	enthalten in contained in
ST167	FJ EINBAUWINKELST. SMC ANGLE CONNECTOR RADIALL R 112 669	FJ 249.9684	300.5434.01
T20	AK 2N2369A NPN 15V 200MA TRANSISTOR VALVO 2N2369A	AK 010.4680	300.5434.01
T21	AK 2N2369A NPN 15V 200MA TRANSISTOR VALVO 2N2369A	AK 010.4680	300.5434.01
T22	AK 2N3209 PNP 20V 100MA TRANSISTOR SGS 2N3209	AK 010.3590	300.5434.01
T23	AK 2N2369A NPN 15V 200MA TRANSISTOR VALVO 2N2369A	AK 010.4680	300.5434.01
T24	AK 2N2369A NPN 15V 200MA TRANSISTOR VALVO 2N2369A	AK 010.4680	300.5434.01
T25	AK 2N3209 PNP 20V 100MA TRANSISTOR SGS 2N3209	AK 010.3590	300.5434.01
T60	AK NE02135 NPN 12V 5GHZ TRANSISTOR NEC NE02135	300.6147	300.5434.01
T61	AK BCY79IX PNP 45V 200MA TRANSISTOR SIEMENS BCY79IX	AK 010.3777	300.5434.01

- ENDE -



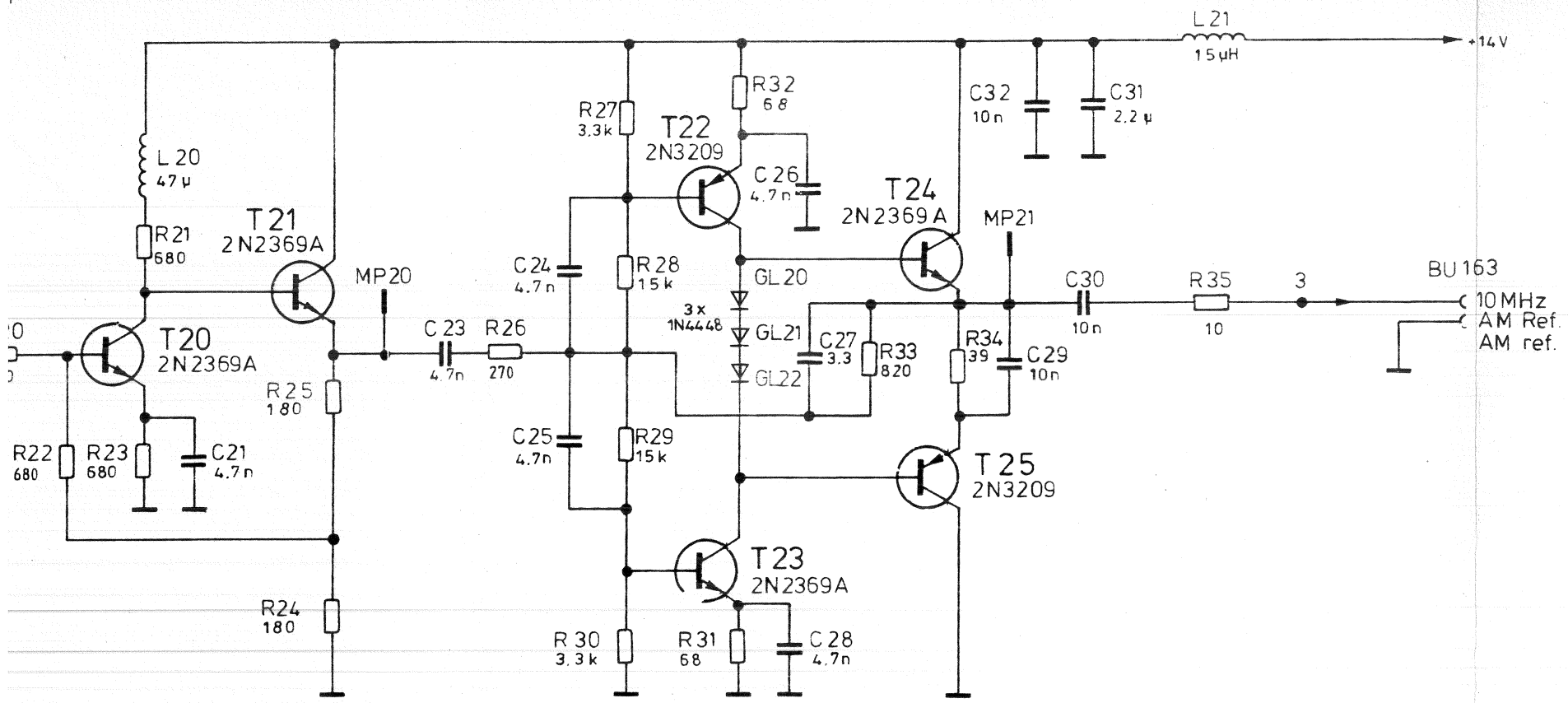

(Platte) AM Modulator+ ALC  
 (PcB) AM modulator and ALC  
 300.5434

---

Zuführung AM-Mod. ALC  
 Feed AM modulator ALC  
 300.5457

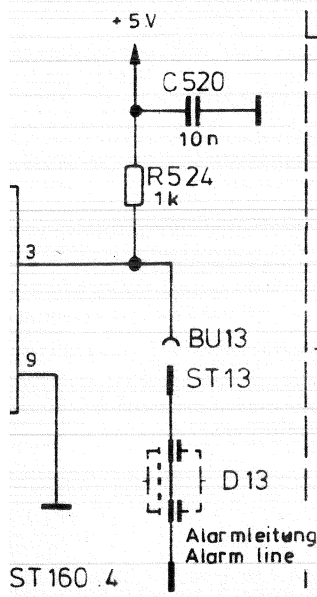
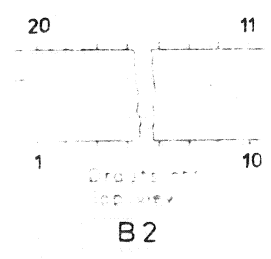
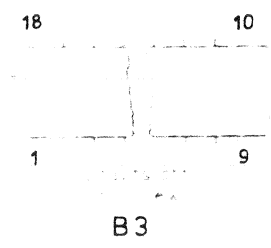
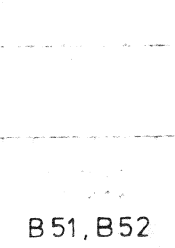
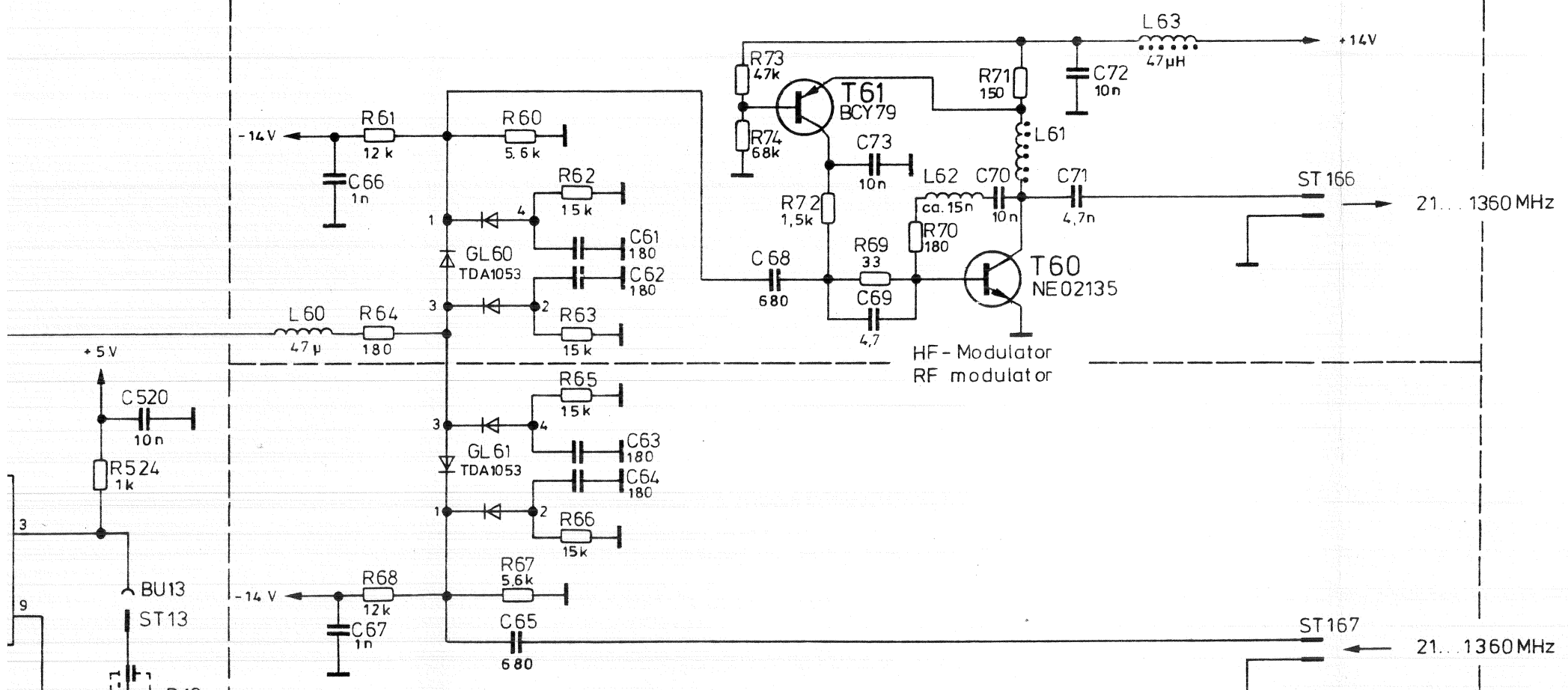
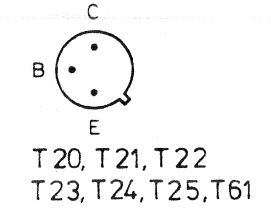
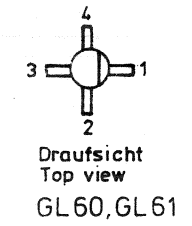
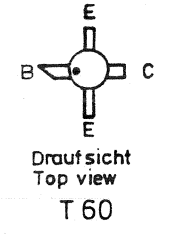
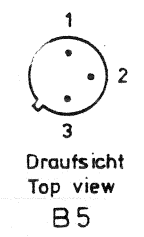

Stromlauf zu  
 AM-Modulator + ALC  
 AM modulator and ALC

Zeichn. Nr. 300.7414 S  
 300.1000 V 300.1000

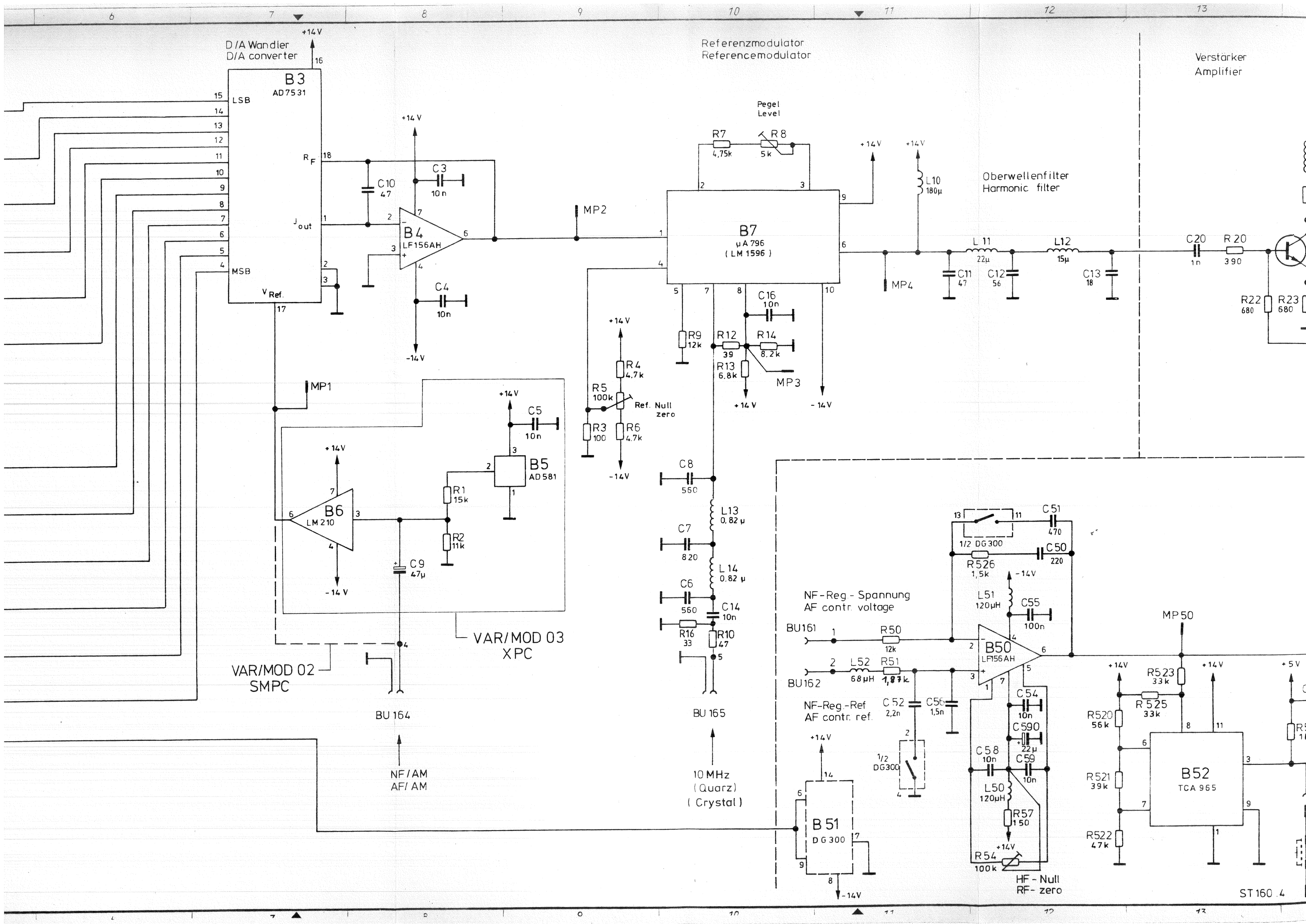

Nr.		zust.		gs		gs		gs		H°	
30063		4.83		30455		9.83		31057		11.83	
H		J		K		L					
32942		12.85									
Diese Zeichnung ist unser Eigentum. Vervielfältigung, unbefugte Verwertung, Mitteilung an andere ist strafbar und schadenersatzpflichtig.											
<b>ROHDE &amp; SCHWARZ · MÜNCHEN</b>											
Nr.		zust.		Bg		Bg		LS		LS	
4		4		79		79		12.80		7.81	
A		B		C		D		G			
27499		27860									
1.2.79		Gü		Di		2.5/1					
1.2.79											
gezeichnet		bearbeitet		geprüft		normgepr.					

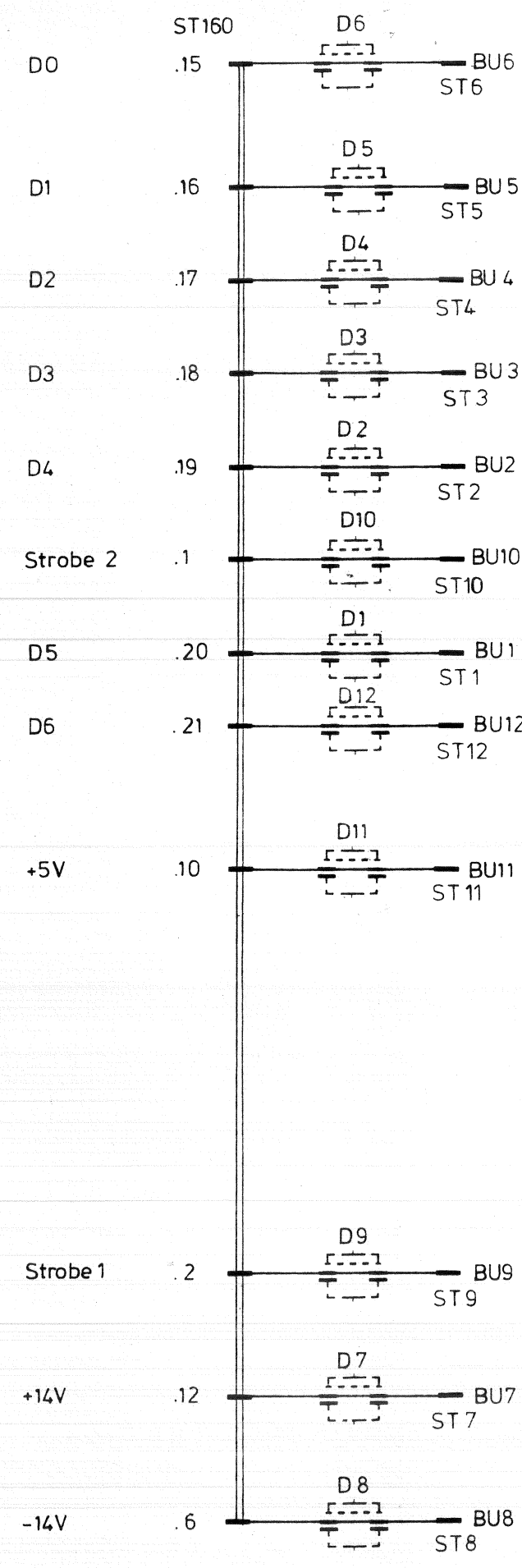
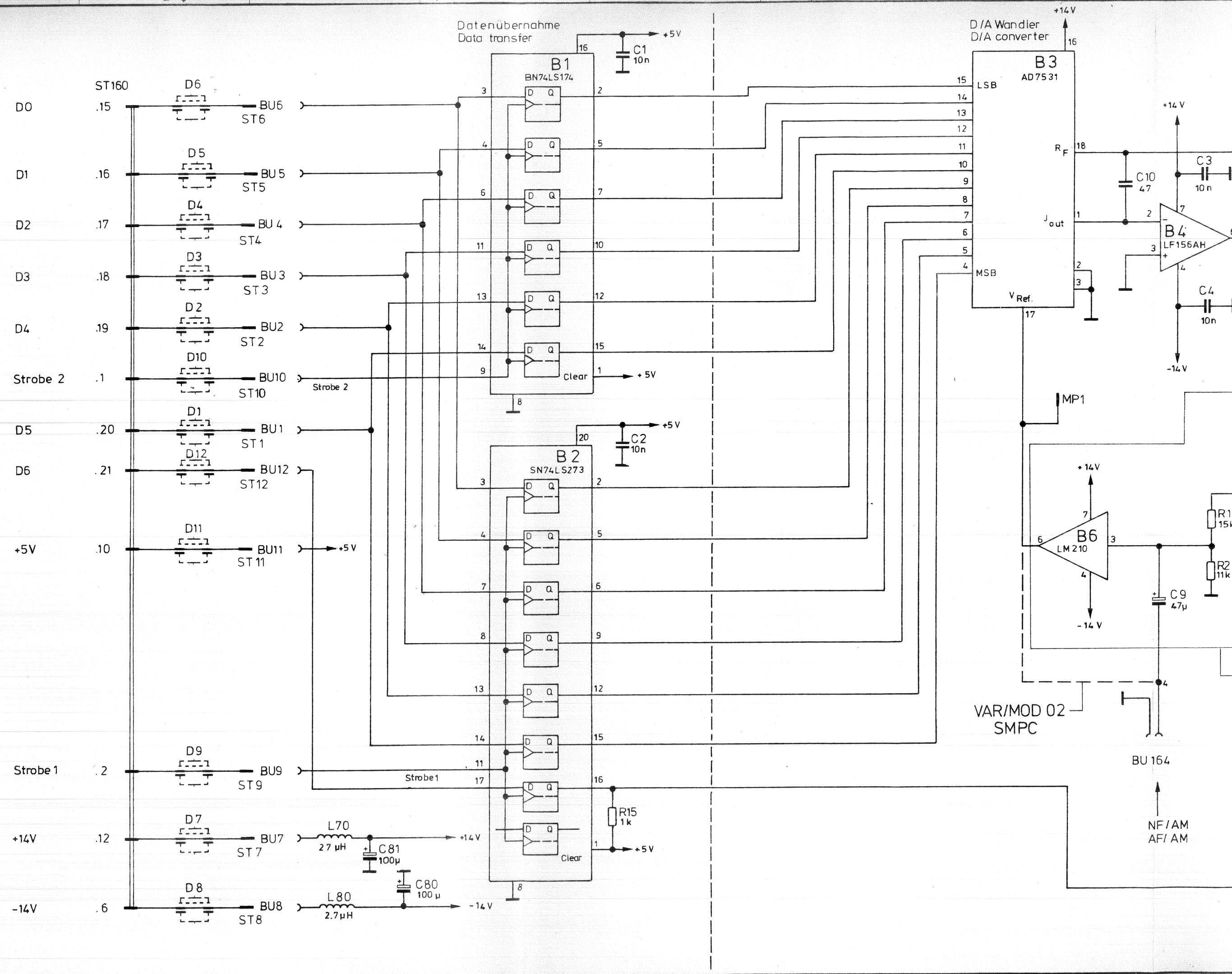



Ansicht und Leitungsführung Bauteilseite  
View of tracks on component side

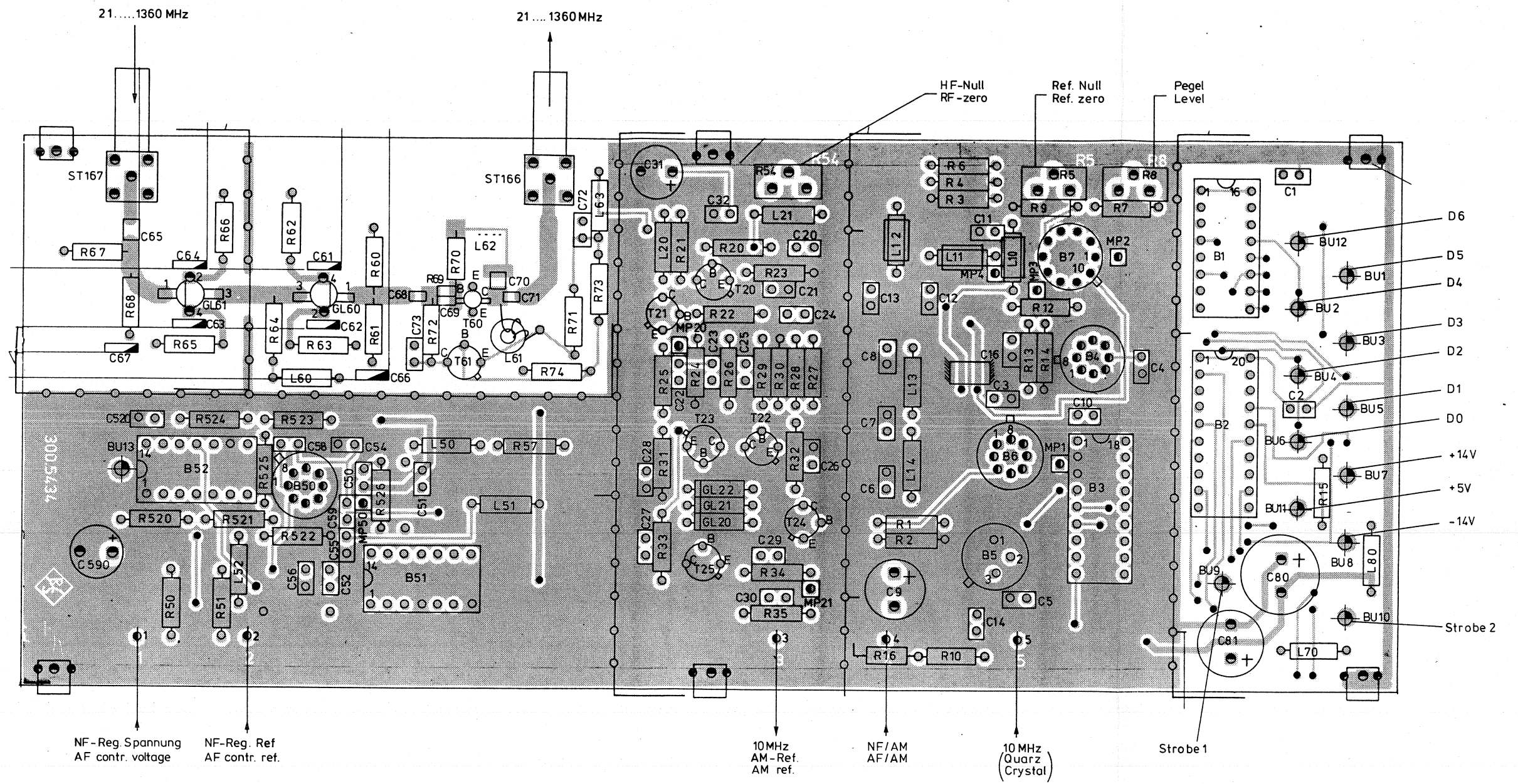

F	27499	24.781	LS	Male ohne Schutzkappe	Maßstab 2:1 Halbzeug Werkstoff															
J	27860	11.82	LS																	
K	30063	4.83	gs																	
L	30455	9.83	gs																	
M	31057	11.83	gs																	
<table border="1"> <tr> <td>IGME</td> <td>Tag</td> <td>Name</td> <td>Benennung</td> </tr> <tr> <td>Bezt</td> <td>24.7.81</td> <td>LS</td> <td>AM-Modulator + ALC</td> </tr> <tr> <td>Gepr</td> <td></td> <td></td> <td>AM modulator and ALC</td> </tr> <tr> <td>Norm</td> <td></td> <td></td> <td></td> </tr> </table>				IGME	Tag	Name	Benennung	Bezt	24.7.81	LS	AM-Modulator + ALC	Gepr			AM modulator and ALC	Norm				Z
IGME	Tag	Name	Benennung																	
Bezt	24.7.81	LS	AM-Modulator + ALC																	
Gepr			AM modulator and ALC																	
Norm																				
<b>ROHDE &amp; SCHWARZ</b>				Zeichn. Nr.	300.5434															
SMPC				Blatt Nr.	2															
300.1000V				erste	300.7414															

Ansicht und Leitungsführung Lötseite  
View of tracks on solder side

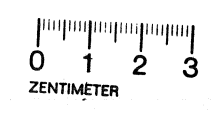
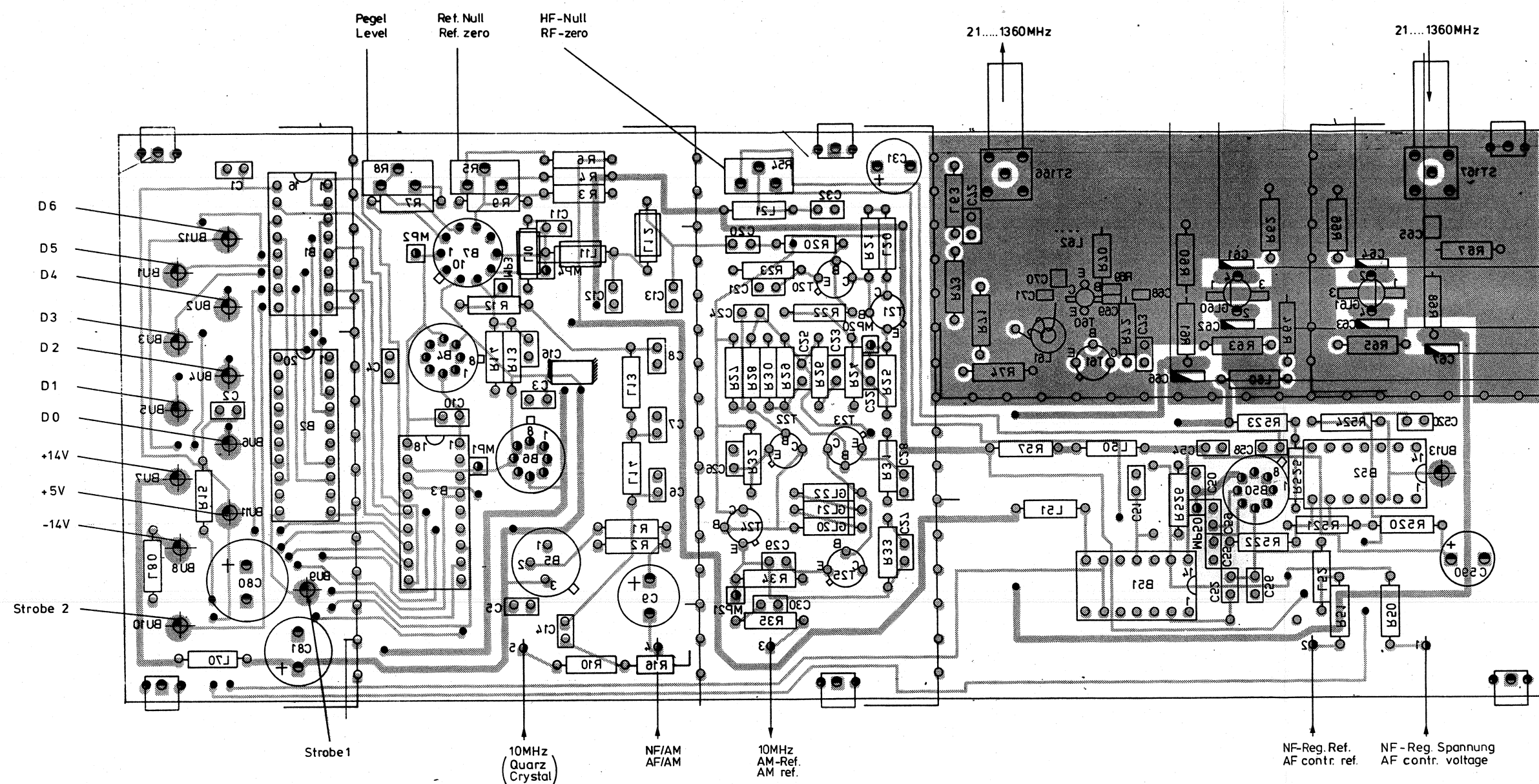

F	27499	24.781	LS	Maße ohne Toleranzangabe	Maßstab 2:1	Haftzeug Werkstoff	Benennung	AM Modulator+ALC AM modulator and ALC	Z	
J	27860	11.82	LS							
K	30063	4.83	gs							
L	30455	9.83	gs							
M	31057	11.83	gs							
				Tag	Name	Benennung				
				Bearb	24.781	LS				
				Gepr						
				Norm						
				ROHDE & SCHWARZ		Zeichn. Nr.		300.5434		Blatt Nr.
				SMPC		reg. 300.1000V		erste Z. 300.741V		3







**ROHDE & SCHWARZ**

SERVICE INSTRUCTIONS FOR

Output Stage I

300.2612 (Y13)

# Table of Contents

		Page
<u>5</u>	<u>Service Instructions for Output Stage I</u>	
	<u>300.2612 (Y13)</u> .....	5.1
5.1	Circuit Description .....	5.1
5.2	Checking and Adjustment Procedures .....	5.1
5.2.1	Checking the Low-pass Filters .....	5.1
5.2.2	Checking the Diode Switches .....	5.1
5.3	Troubleshooting .....	5.1
5.3.1	Interfaces .....	5.3

Parts list  
Circuit diagram  
Components location plans



### 5.1 Circuit Description

(See circuit diagram 300.2612 S and Fig. 5-1)

The Y13 contains eight switchable low-pass filters spaced one-half octave apart for separation of harmonics. Altogether twelve low-pass filters are provided in Y13 and Y14 which are combined in three groups of four filters each.

### 5.2 Checking and Adjustment Procedures

#### 5.2.1 Checking the Low-pass Filters

Connect sweep test assembly: sweep generator to ST171 and detector to ST174. Trace filter curves and compare with the nominal data listed in Table 5-2. To switch on the filter to be measured set frequency on XPC/SMPC to between  $f_1$  and  $f_{pass}$ . For control voltages see Table 5-1.

#### 5.2.2 Checking the Diode Switches

Connect sweep test assembly: sweep generator to ST171 and detector to ST172. Set frequency on XPC/SMPC to 40 MHz. The pass-band attenuation should be  $< 3$  dB from 20 to 100 MHz. Set frequency on XPC/SMPC to 100 MHz. The stop-band attenuation should be  $> 40$  dB from 20 to 100 MHz. Repeat measurement with sweep generator connected to ST173 and detector to ST174.

### 5.3 Troubleshooting

Check function of diode switches with reference to control voltages according to Table 5-1.

Table 5-1 Control voltages for filter test

Filter (Code)	ST 170													
	J	7	11	5	3	2	H	1	9	4	K	M	P	13
4		1			1		1							
5		1			1			1						
6		1			1				1					
7		1			1					1				
8			1			1					1			
9			1			1						1		
10			1			1							1	
11			1			1								1

"1" stands for +18 ±1 V, otherwise -5 ±1 V applies.

Table 5-2 Nominal filter curves

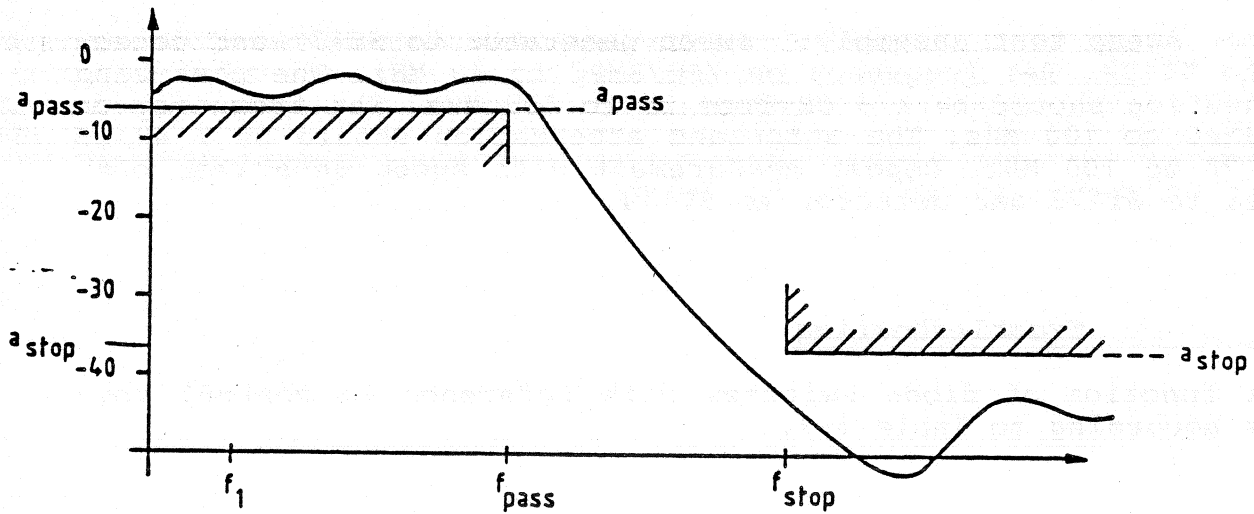

Filter (Code)	f <sub>1</sub> /MHz	f <sub>pass</sub> /MHz	f <sub>stop</sub> /MHz	a <sub>pass</sub> /dB	a <sub>stop</sub> /dB
4	85	120	170	-7	-37
5	120	170	240	-7	-37
6	170	240	340	-7	-37
7	240	340	481	-7	-37
8	340	481	680	-9	-39
9	481	680	962	-9	-39
10	680	962	1360	-10	-40
11	962	1360	1924	-12	-37

### 5.3.1 Interfaces

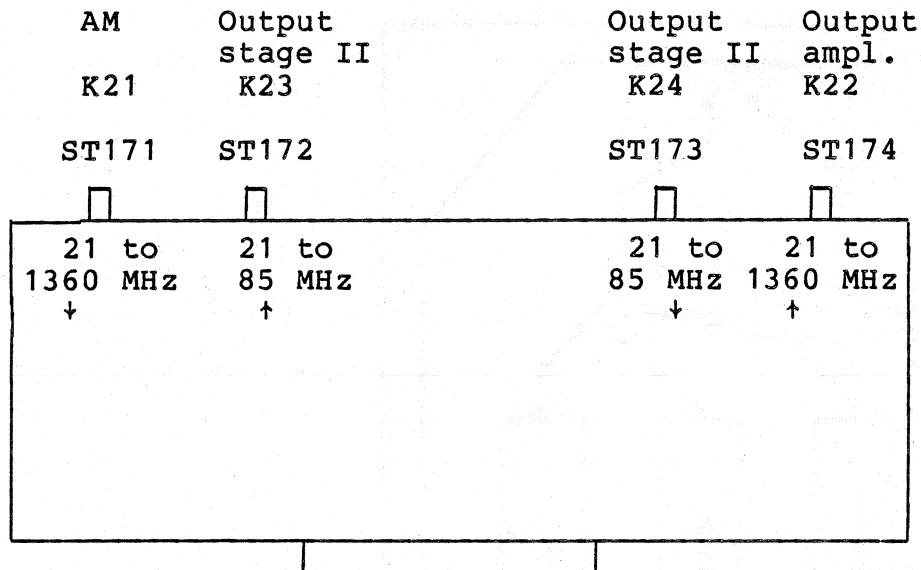

ST/BU	171	172	173	174
f	21 to 1360 MHz	21 to 85 MHz	21 to 85 MHz	21 to 1360 MHz
Level	3 to 11 dBm	3 to 11 dBm	0 to 8 dBm	0 to 8 dBm
Z	50 $\Omega$	50 $\Omega$	50 $\Omega$	50 $\Omega$
AC-DC	AC	AC	AC	AC
Shape of curve	rectangular	rectangular	sinusoidal	sinusoidal

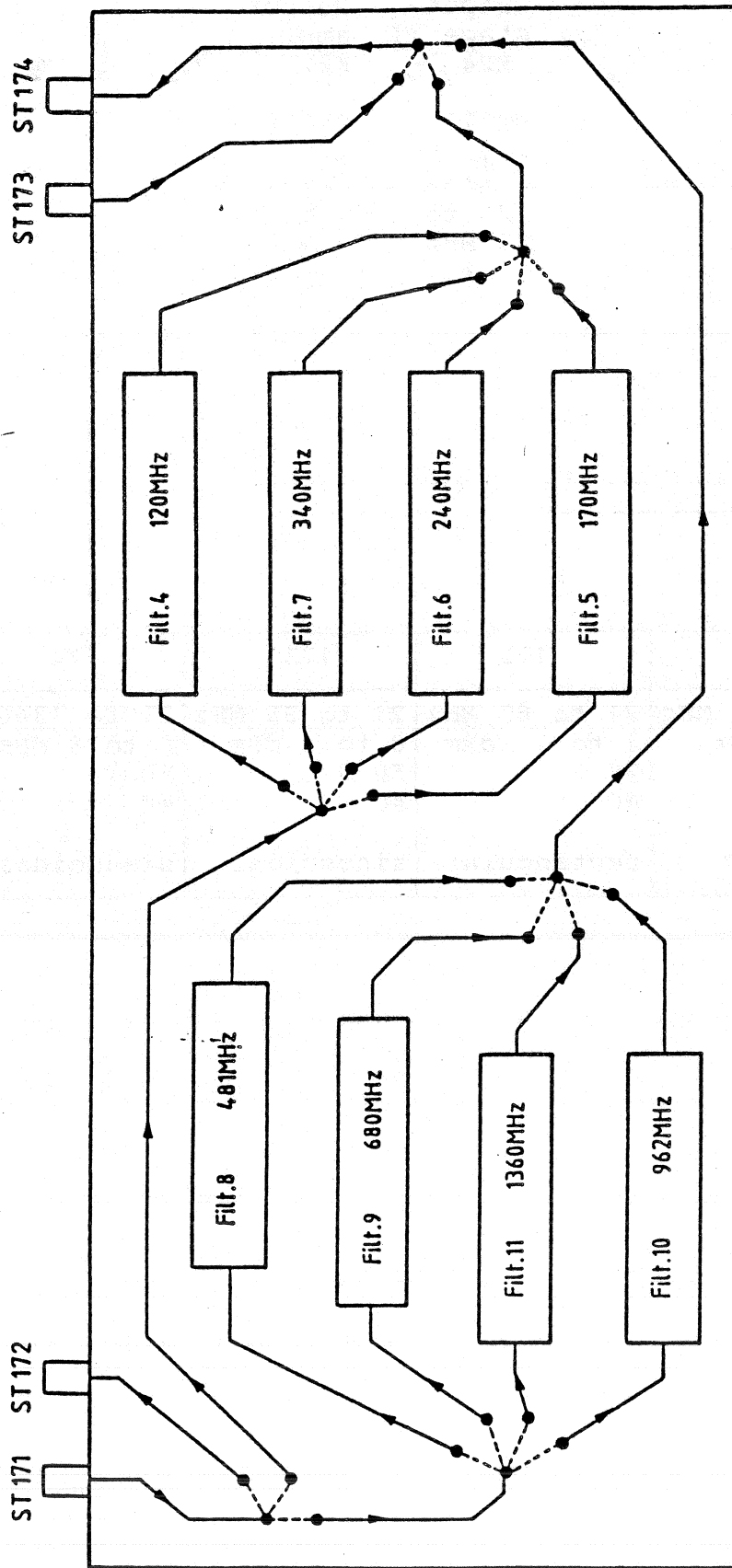

Fig. 5-1 Block diagram of output stage I



ROHDE & SCHWARZ  
MÜNCHEN

Schaltteillisten  
Stromläufe  
Bestückungspläne  
Parts lists  
Circuit diagrams  
Components plans

Kennzeichen Component No.	Benennung/Beschreibung Designation	Sachnummer Stock No.	enthalten in contained in
BU1	FP BUCHSE VERTIKAL P.V.1P SOCKET BERG 75377-001	FP 278.5577	300.5470
BIS/TO BU14			
C1	CC 1,5NF+-10%100V3K1200 C CAPACITOR VITRAMON VJ1005Y152K FB	CC 082.3244	300.5470
C2	CC 10NF-20+50%7X8R6000 CAPACITOR VALVO 2222 63051 64051103	CC 087.7525	300.5470
C3	CC 6,8NF+-10% 50V3K1200 C CAPACITOR VITRAMON VJ1005Y682K FB	CC 082.3321	300.5470
C4	CC 10PF+-5% N150 TRAPEZ CAPACITOR STETTNER TEFK7,10PF5%,N150	CC 249.9284	300.5470
C5	CC 15PF+-5% N470 TRAPEZ CAPACITOR STETTNER TEFK7,15PF5%,N470	CC 249.9303	300.5470
C6	CC 15PF+-5% N470 TRAPEZ CAPACITOR STETTNER TEFK7,15PF5%,N470	CC 249.9303	300.5470
C7	CC 10PF+-5% N150 TRAPEZ CAPACITOR STETTNER TEFK7,10PF5%,N150	CC 249.9284	300.5470
C8	CC 6,8PF+-0,5PF NPO TRAP CAPACITOR STETTNER TEFK7-6,8/0,5NPO	CC 249.9261	300.5470
C9	CC 10PF+-5% N150 TRAPEZ CAPACITOR STETTNER TEFK7,10PF5%,N150	CC 249.9284	300.5470
C10	CC 10PF+-5% N150 TRAPEZ CAPACITOR STETTNER TEFK7,10PF5%,N150	CC 249.9284	300.5470
C11	CC 6,8PF+-0,5PF NPO TRAP CAPACITOR STETTNER TEFK7-6,8/0,5NPO	CC 249.9261	300.5470
C12	CC 3,3PF+-0,25PF P100TRAP CAPACITOR SIEMENS B38280-A5030-D302	CC 083.6630	300.5470
C13	CC 5,6PF+-0,5PF7NPO TRAP. CAPACITOR STETTNER TEFK7,NP05,6PF0,5PF	CC 249.9378	300.5470
C14	CC 5,6PF+-0,5PF7NPO TRAP. CAPACITOR STETTNER TEFK7,NP05,6PF0,5PF	CC 249.9378	300.5470
C15	CC 3,3PF+-0,25PF P100TRAP CAPACITOR SIEMENS B38280-A5030-D302	CC 083.6630	300.5470
C16	CC 4,7PF+-0,5PF7NPO TRAP CAPACITOR STETTNER TEFK7,4,7PF/0,5PF,NP	CC 417.8603	300.5470
		300.2612.00 SA	BL 1+

 Für diese Unterlage behalten wir  
 uns alle Rechte vor

**ROHDE & SCHWARZ**

ÄZ

Datum  
Date

12

0686

Schaltteilliste für  
Parts list for  
ZM AUSGANGSTEIL I  
OUTPUT STAGE ISachnummer  
Stock No.

300.2612.00 SA

Blatt  
Page

2

Kennzeichen Component No.	Benennung/Beschreibung Designation	Sachnummer Stock No.	enthalten in contained in
C17	CC 6,8PF+-0,5PF NPO TRAP CAPACITOR STETTNER TEFK7-6,8/0,5NPO	CC 249.9261	300.5470
C18	CC 6,8PF+-0,5PF NPO TRAP CAPACITOR STETTNER TEFK7-6,8/0,5NPO	CC 249.9261	300.5470
C19	CC 4,7PF+-0,5PF7NPO TRAP CAPACITOR STETTNER TEFK7,4,7PF/0,5PF,NP	CC 417.8603	300.5470
C30	CC 4,7NF+-10%6X9R2000 CAPACITOR	CC 087.7102	300.5470
C31	VALVO 2222 63051 472 CC 39PF+-2%4X5NPO CAPACITOR	CC 087.6493	300.5470
C32	VALVO 2222 678 10399 CC 56PF+-2%5X6N150 CAPACITOR	CC 087.6687	300.5470
C33	VALVO 2222 678 34569 CC 56PF+-2%5X6N150 CAPACITOR	CC 087.6687	300.5470
C34	VALVO 2222 678 34569 CC 39PF+-2%4X5NPO CAPACITOR	CC 087.6493	300.5470
C35	VALVO 2222 678 10399 CC 12PF+-2%3X4NPO CAPACITOR	CC 087.6435	300.5470
C36	VALVO 2222 678 10129 CC 22PF+-2%3X4N150 CAPACITOR	CC 087.6635	300.5470
C37	VALVO 2222 678 34229 CC 22PF+-2%3X4N150 CAPACITOR	CC 087.6635	300.5470
C38	VALVO 2222 678 34229 CC 12PF+-2%3X4NPO CAPACITOR	CC 087.6435	300.5470
C39	VALVO 2222 678 10129 CC 18PF+-2%3X4NPO CAPACITOR	CC 087.6458	300.5470
C40	VALVO 2222 678 10189 CC 27PF+-2%4X5N150 CAPACITOR	CC 087.6641	300.5470
C41	VALVO 2222 678 34279 CC 27PF+-2%4X5N150 CAPACITOR	CC 087.6641	300.5470
C42	VALVO 2222 678 34279 CC 18PF+-2%3X4NPO CAPACITOR	CC 087.6458	300.5470
C43	VALVO 2222 678 10189 CC 27PF+-2%4X5N150 CAPACITOR	CC 087.6641	300.5470
C44	VALVO 2222 678 34279 CC 39PF+-2%4X5NPO CAPACITOR	CC 087.6493	300.5470
C45	VALVO 2222 678 10399 CC 39PF+-2%4X5NPO CAPACITOR	CC 087.6493	300.5470
	VALVO 2222 678 10399		

300.2612.00 SA BL 2+

**ROHDE & SCHWARZ**

ÄZ	Datum
12	0686

Schalteilliste für
Parts list for
ZM AUSGANGSTEIL I
OUTPUT STAGE I

Sachnummer
Stock No.
300.2612.00 SA

Blatt
Page
3

Kennzeichen Component No.	Benennung/Beschreibung Designation	Sachnummer Stock No.	enthalten in contained in
C46	CC 27PF+-2%4X5N150 CAPACITOR VALVO 2222 678 34279	CC 087.6641	300.5470
C47	CC 10NF-20+50%7X8R6000 CAPACITOR VALVO 2222 63051 64051103	CC 087.7525	300.5470
C48	CC 10NF+-10% 50V3K1200 CH CAPACITOR VITRAMON VJ1005Y103KFB	CC 082.3344	300.5470
C49	CC 4,7NF+-10%6X9R2000 CAPACITOR VALVO 2222 63051 472	CC 087.7102	300.5470
C50	CC 6,8NF+-10% 50V3K1200 C CAPACITOR VITRAMON VJ1005Y682KFB	CC 082.3321	300.5470
C55	CC 220PF+-2%6X7N750 CAPACITOR VALVO 2222 678 58221	CC 087.6941	300.5470
D1	LD 35DB/200M-10GHZ PI-FIL CHOKE ERIE 1214-038	LD 300.6818	300.5492
BIS/TO D14			
GL1	AE BA379 PIN DIODE	300.6918	300.5470
GL2	AE BA379 PIN DIODE	300.6918	300.5470
GL3	AE BA379 PIN DIODE	300.6918	300.5470
GL4	AE BA379 PIN DIODE	300.6918	300.5470
GL5	AE BA379 PIN DIODE	300.6924	300.5470
GL6	AE BA379 PIN DIODE	300.6918	300.5470
GL7	AE BA379 PIN DIODE	300.6924	300.5470
GL8	AE BA379 PIN DIODE	300.6918	300.5470
GL9	AE BA379 PIN DIODE	300.6924	300.5470
GL10	AE BA379 PIN DIODE	300.6918	300.5470
GL11	AE BA379 PIN DIODE	300.6924	300.5470
GL12	AE BA379 PIN DIODE	300.6918	300.5470
GL13	AE BA379 PIN DIODE	300.6918	300.5470
GL14	AE BA379 PIN DIODE	300.6918	300.5470
GL15	AE BA379 PIN DIODE	300.6918	300.5470
		300.2612.00 SA	BL 3+

Für diese Unterlage behalten wir  
uns alle Rechte vor



**ROHDE & SCHWARZ**

ÄZ

Datum  
Date

12

0686

Schaltteilliste für  
Parts list for  
ZM AUSGANGSTEIL I  
OUTPUT STAGE ISachnummer  
Stock No.

300.2612.00 SA

Blatt  
Page

4

Kennzeichen Component No.	Benennung/Beschreibung Designation	Sachnummer Stock No.	enthalten in contained in
GL25	AE BA379 PIN DIODE	300.6918	300.5470
GL26	AE BA379 PIN DIODE	300.6924	300.5470
GL27	AE BA379 PIN DIODE	300.6918	300.5470
GL28	AE BA379 PIN DIODE	300.6924	300.5470
GL29	AE BA379 PIN DIODE	300.6918	300.5470
GL30	AE BA379 PIN DIODE	300.6924	300.5470
GL31	AE BA379 PIN DIODE	300.6918	300.5470
GL32	AE BA379 PIN DIODE	300.6924	300.5470
GL33	AE BA379 PIN DIODE	300.6918	300.5470
GL34	AE BA379 PIN DIODE	300.6918	300.5470
GL35	AE BA379 PIN DIODE	300.6918	300.5470
GL36	AE BA379 PIN DIODE	300.6918	300.5470
GL37	AE BA379 PIN DIODE	300.6918	300.5470
GL38	AE BA379 PIN DIODE	300.6918	300.5470
GL39	AE BA379 PIN DIODE	300.6918	300.5470
BIS/TO GL43			
GL52	AE BA379 PIN DIODE	300.6918	300.5470
GL53	AE BA379 PIN DIODE	300.6918	300.5470
GL54	AE BA379 PIN DIODE	300.6918	300.5470
GL56	AE BA379 PIN DIODE	300.6918	300.5470
L7 BIS/TO L12	ENTHALTEN IN/INCLUDED IN		300.5470
L20	LEITERPLATTE / PCB LL SPULE 104NH COIL	300.6518	300.5470
L21	LL SPULE 116NH COIL	300.6524	300.5470
L22	LL SPULE 104NH COIL	300.6518	300.5470
L23	LL SPULE 30NH COIL	300.6530	300.5470
L24	LL SPULE 28 NH COIL	300.6547	300.5470
		300.2612.00 SA	BL 4+

uns alle Rechte vor

**ROHDE & SCHWARZ**

ÄZ	Datum
12	0686

Schaltteilliste für  
Parts list for  
ZM AUSGANGSTEIL I  
OUTPUT STAGE I

Sachnummer  
Stock No.

300.2612.00 SA

Blatt  
Page

5

Kennzeichen Component No.	Benennung/Beschreibung Designation	Sachnummer Stock No.	enthalten in contained in
L25	LL SPULE 30NH COIL	300.6530	300.5470
L26	LL SPULE 49 NH COIL	300.6553	300.5470
L27	LL SPULE 55NH COIL	300.6560	300.5470
L28	LL SPULE 49 NH COIL	300.6553	300.5470
L29	LL SPULE 80 NH COIL	300.6576	300.5470
L30	RADIALL R.299 017 LL SPULE 90 NH COIL	300.6582	300.5470
L31	LL SPULE 80 NH COIL	300.6576	300.5470
L55	RADIALL R.299 017 LD 1,2UH 2%0,180HMO,62A CHOKE DELEVAN 1025-22 +-2%	337.8795	300.5470
R1	RL 0,21W 1,0KOHM2% UNGEW. RESISTOR RESISTA MK1 1K 2% UNGEW.	RL 092.6075	300.5470
BIS/TO R10 R20	RL 0,21W 1,0KOHM2% UNGEW. RESISTOR RESISTA MK1 1K 2% UNGEW.	RL 092.6075	300.5470
BIS/TO R29			
ST1	FP EINZELKONTAKTSTIFT SINGLE-CONTACT PIN ULMIC R&S.ZCHNG.300.8804	300.8804	300.5492
BIS/TO ST14 ST170	ENTHALTEN IN/INCLUDED IN LEITERPLATTE/PCB		300.5492
ST171	FJ EINBAUWINKELST. SMC ANGLE CONNECTOR RADIALL R 112 669	FJ 249.9684	300.5470
BIS/TO ST174			
			- ENDE -

300.2612.00 SA BL 5-

1z  
72

21-85 MHz

21-1360 MHz

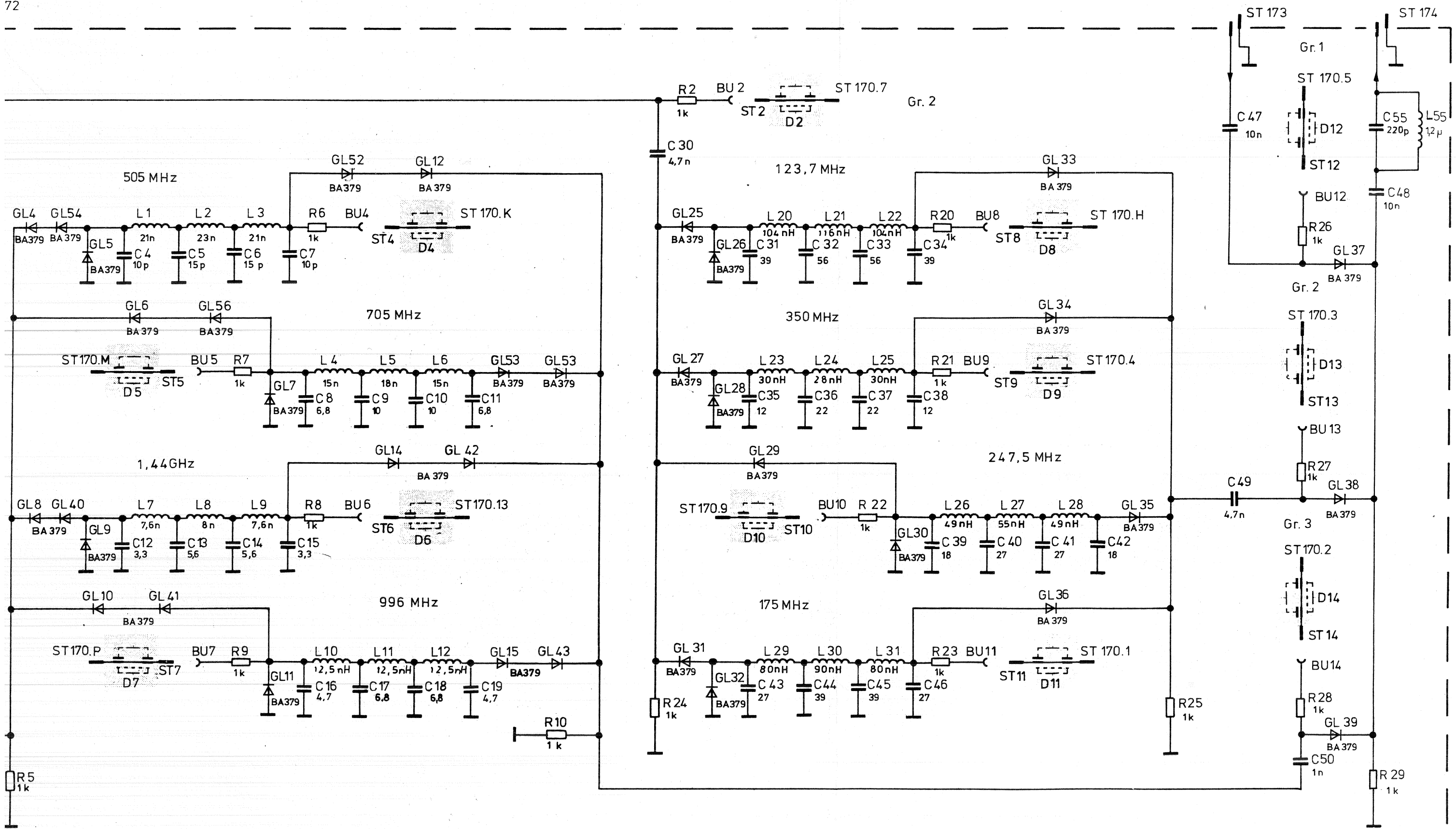

300.5470

Stromlauf zu  
AUSGANGSTEIL I  
Output stage I

Z	Zeichn. Nr. 300.2612 S	
	300.1000 V	300.1000



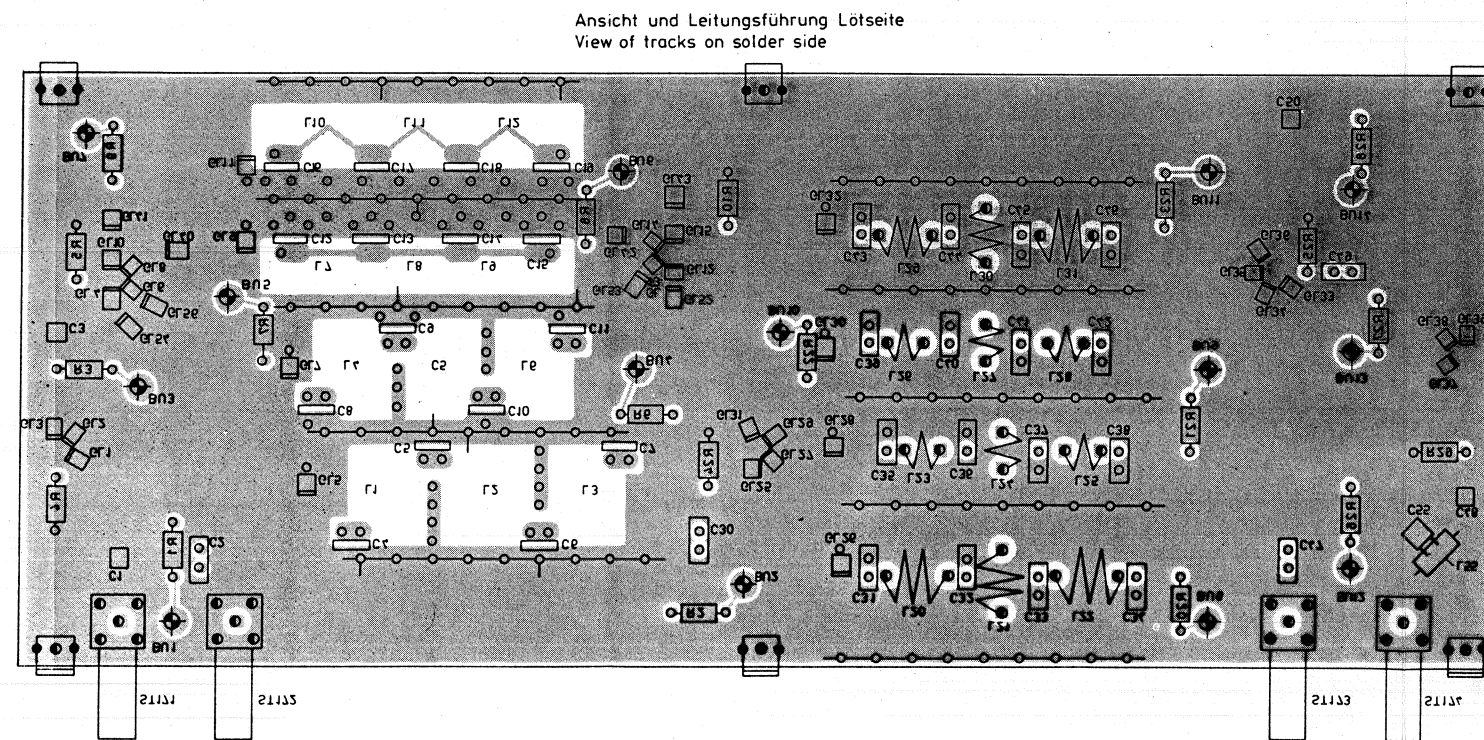
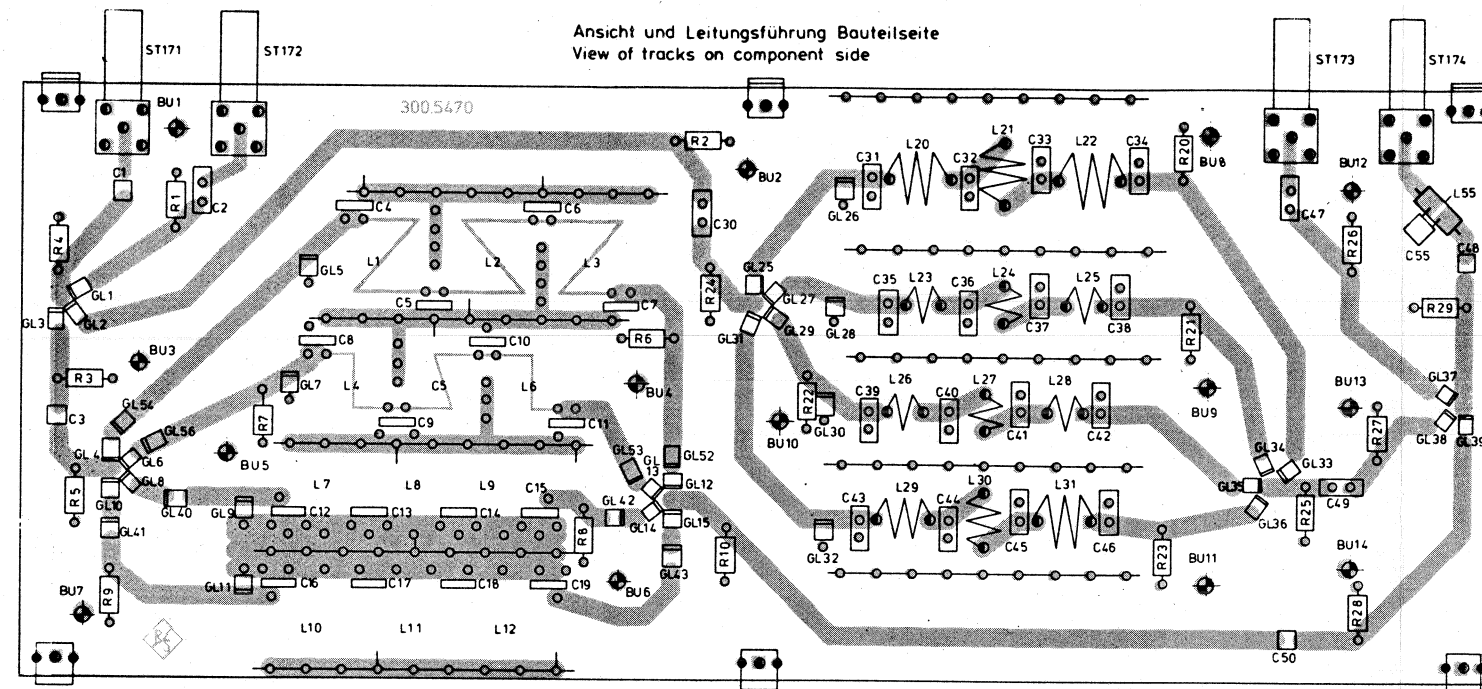

0 1 2 3  
ZENTIMETER

D	30.4.79	Er	Maße ohne	Maßstab	2 1
E	27.9.99	LS	Toleranzangabe		
G	27.8.60	LS			Maßzeug Werkstoff
			IGMA	Tag	Name
			Bearb.	30.4.79	Er
			Gepr.	2.70	
			Norm		
					Benennung
					Ausgangsteil I
					Output stage I
					Zeichn. Nr.
					300.5470
					Blatt Nr.
					2
					von
					300.100.00
					Seite 2 von 2



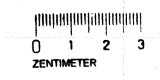
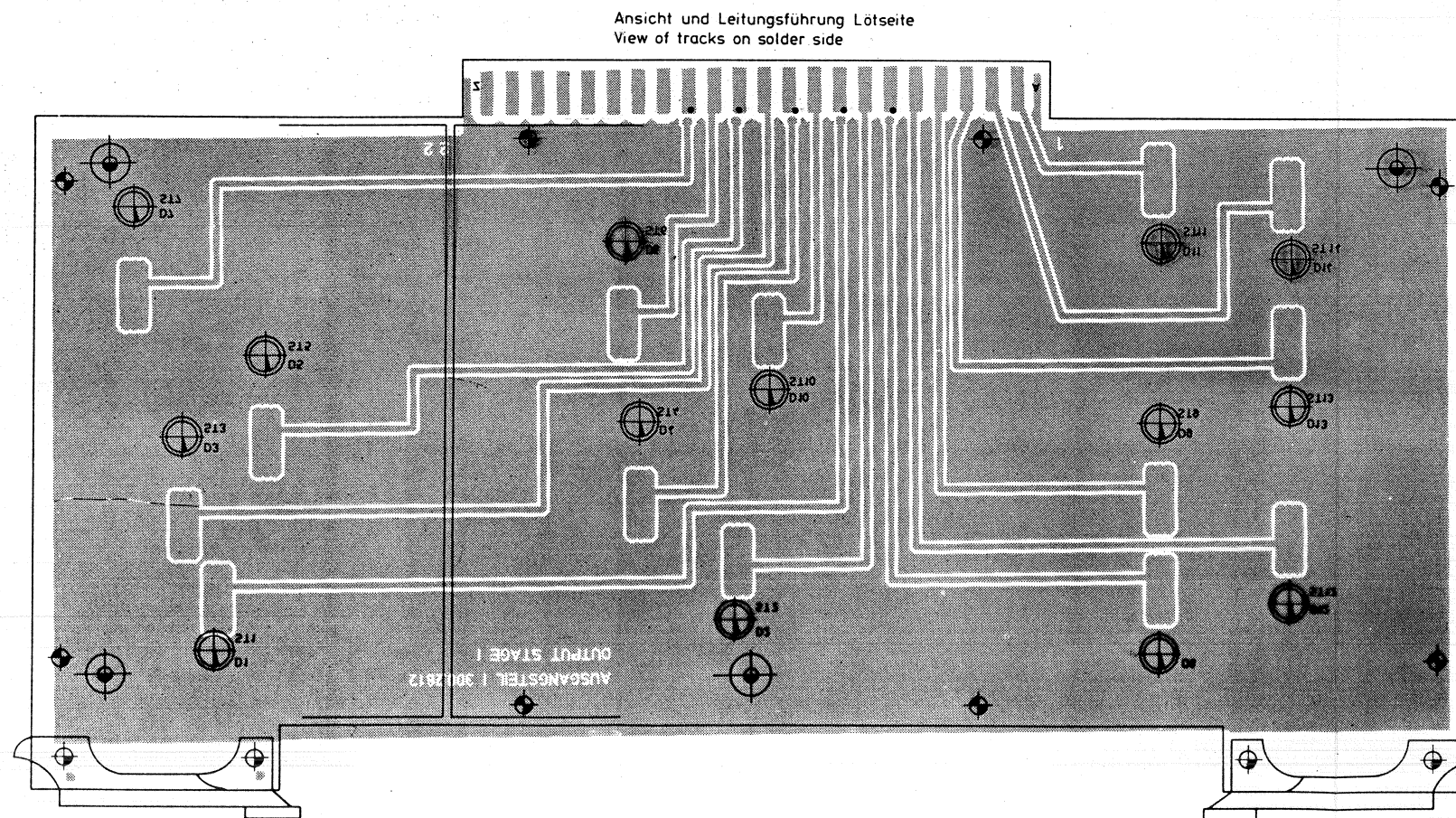
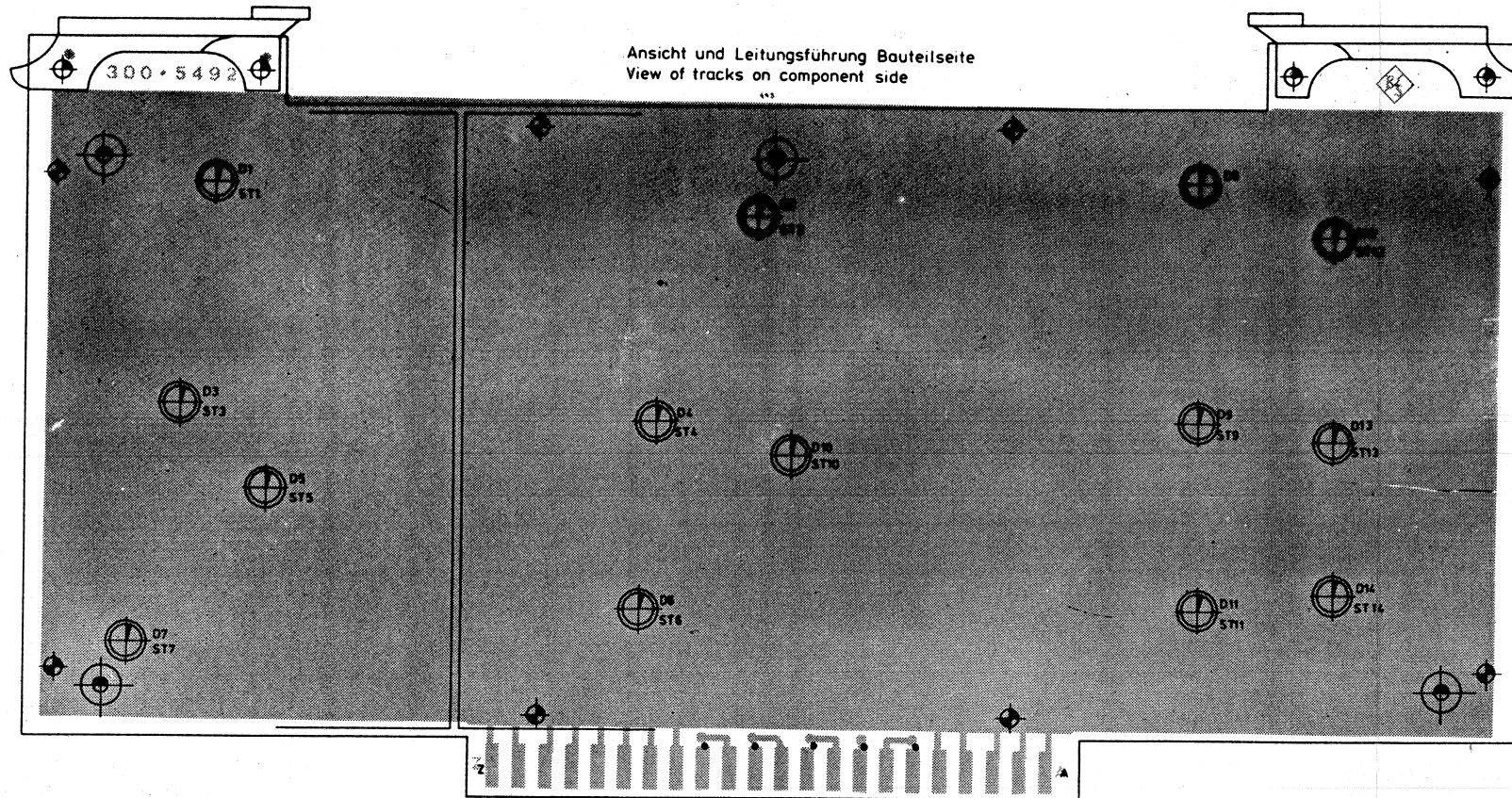

0	12.2.79	Wm	Maße ohne Toleranzangabe	Maßstab	
				Halbzeug, Werkstoff	
			IGME Tag Name	Benennung	Z
			Bearb. 12.2.79 Wm	Zuf - Ausgangsteil I	
			Gepr. S. 22	Feed-output stage I	
			Norm.		
			<b>ROHM &amp; SCHAUB</b>	Zechn.-Nr.	Blatt-Nr.
			zu Gerät S.M.P.C.	300.5492	2
				reg. V 300.1000V	1. erste Z. 300.2612



**ROHDE & SCHWARZ**

SERVICE INSTRUCTIONS FOR

Output Stage II

300.3560 (Y14)

# Table of Contents

	Page	
<u>5</u>	<u>Service Instructions for Output Stage II</u>	
	<u>300.3560 (Y14)</u> .....	5.1
5.1	Circuit Description .....	5.1
5.2	Checking and Adjustment Procedures .....	5.1
5.2.1	Checking the Low-pass Filters .....	5.1
5.2.2	Checking the Control Circuit .....	5.2
5.3	Troubleshooting .....	5.3
5.3.1	Interfaces .....	5.3

Parts list  
Circuit diagram  
Components location plans



### 5.1 Circuit Description

(See circuit diagram 300.3560 S and Fig. 5-1)

Y14 comprises the digital control circuit and the drivers for Y13 to Y15. According to the code number sent from the CPU (Y1) one of twelve filter ranges or the mixer range is selected. The lower four electronically switched low-pass filters are located on the Y14.

### 5.2 Checking and Adjustment Procedures

#### 5.2.1 Checking the Low-pass Filters

Connect sweep test assembly: sweep generator to ST181 and detector to ST182. Trace filter curves and compare with the nominal data listed in Table 5-1. To switch on the filter to be checked set frequency on XPC/SMPC to between  $f_1$  and  $f_{pass}$ .

Table 5-1 Nominal filter curves

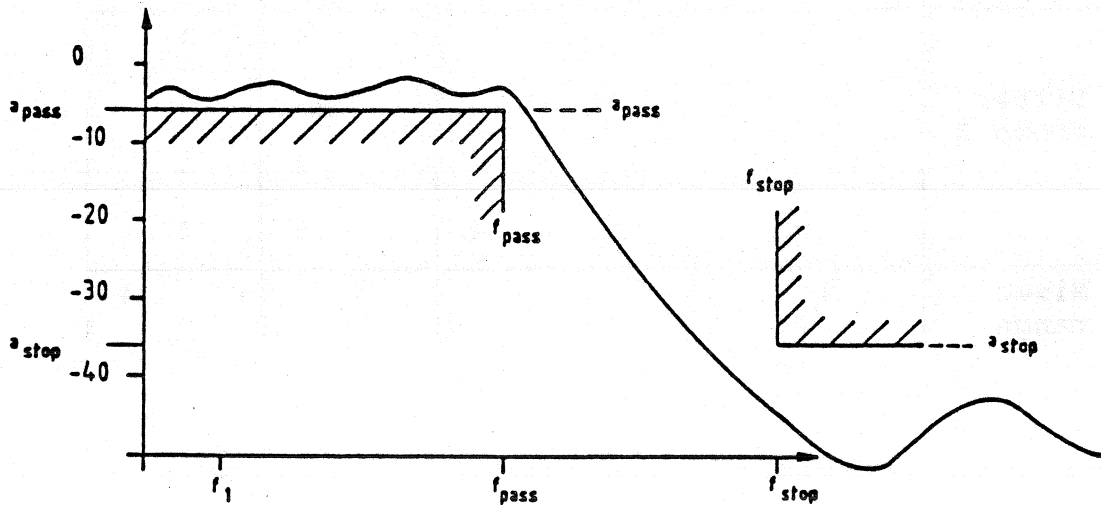

Filter (Code)	$f_1$ /MHz	$f_{pass}$ /MHz	$f_{stop}$ /MHz	$a_{pass}$ /dB	$a_{stop}$ /dB
0	21.25	30	42.5	-5	-35
1	30	42.5	60	-5	-35
2	42.5	60	85	-5	-35
3	60	85	120	-5	-35

**5.2.2 Checking the Control Circuit**

Measure voltages according to Table 5-2.

Table 5-2

At ST180: 1 corresponds to  $18 \pm 1.5$  V, otherwise  $-6 \pm 1$  V applies.

Status code		ST180													
		11	J	7	9	E	D	5	H	2	1	A	C	3	B
0	Filter group 1 (in output stage II)									1				1	
1										1				1	
2										1				1	
3										1				1	
4	Filter group 2	1									1			1	
5			1								1			1	
6				1							1			1	
7					1						1			1	
8	Filter group 3					1						1		1	
9							1					1		1	
10								1				1		1	
11									1			1		1	
12	Mixer range		1								1		1		1

### 5.3 Troubleshooting

For signature analysis see CPU (Y1).

#### 5.3.1 Interfaces

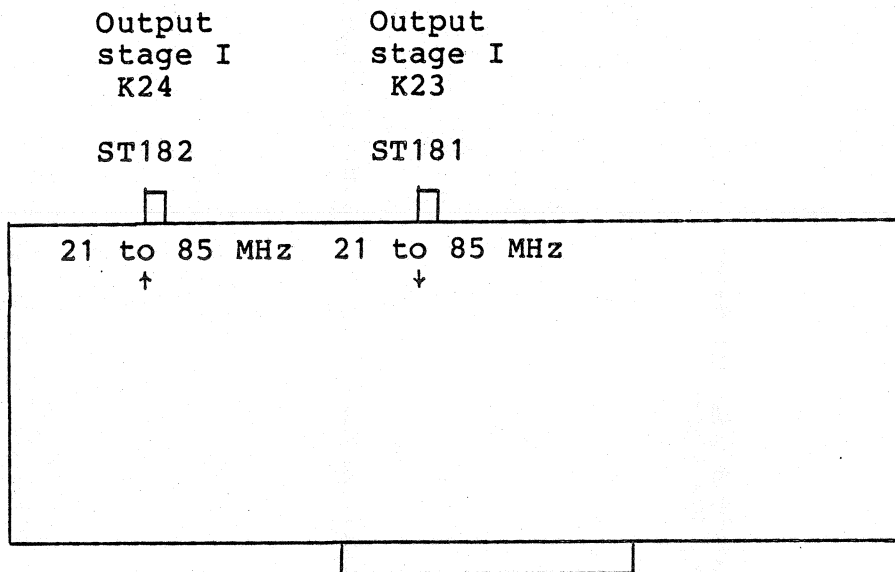

ST/BU	181	182
f	21 to 85 MHz	21 to 85 MHz
Level	3 to 11 dBm	0 to 8 dBm
Z	50 Ω	50 Ω
AC-DC	AC	AC
Shape of curve	rectangular	sinusoidal

#### Digital Interface

1 strobe, data: 12 filter ranges,  
1 mixer range,  
binary digit 4 bits.

	D7	6	5	4	3	2	1	0
Strobe 1	x	x	x	x	MSB	-----	LSB	
	Binary status code							

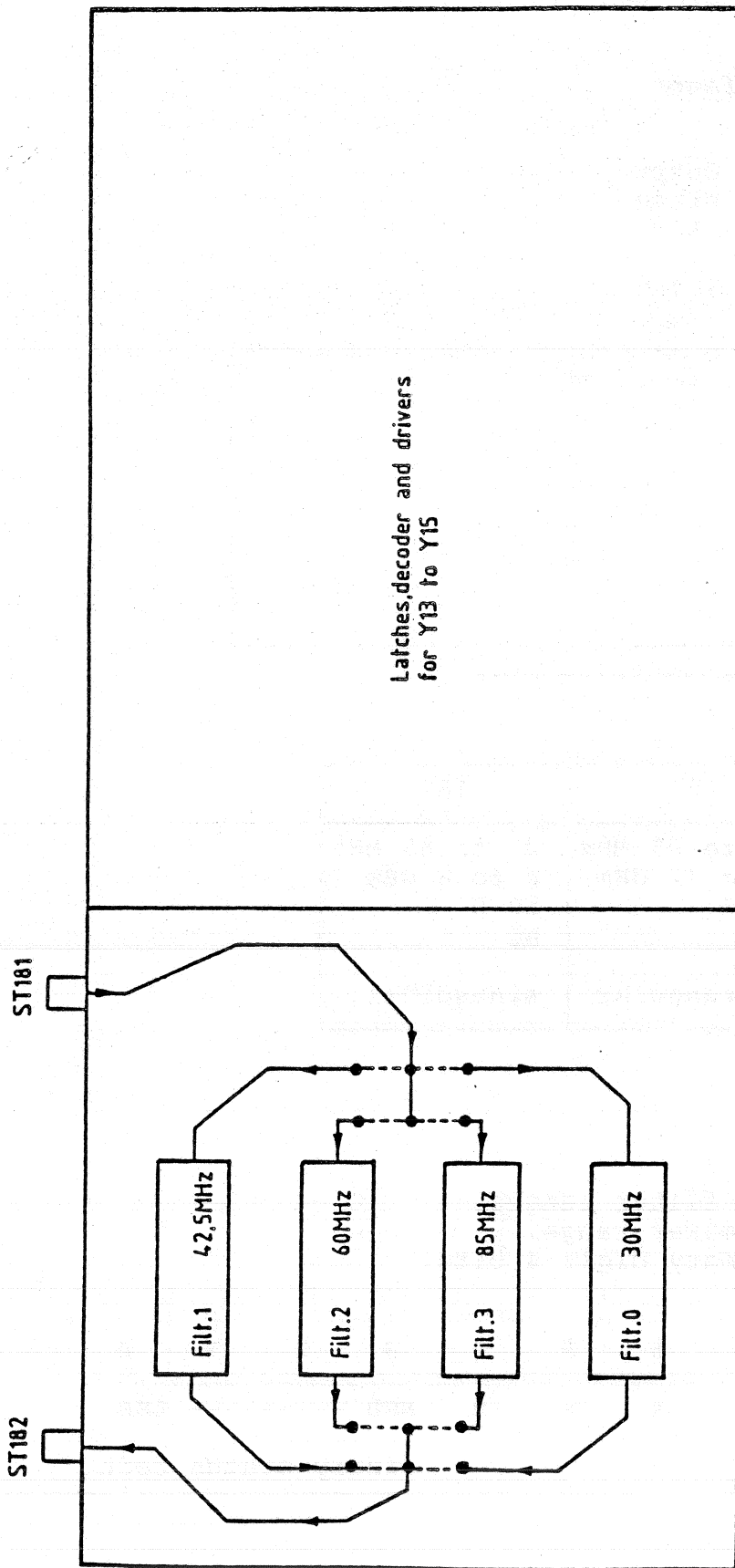

Fig. 5-1 Block diagram of output stage II



ROHDE & SCHWARZ  
MÜNCHEN

Schalteillisten  
Stromläufe  
Bestückungspläne  
Parts lists  
Circuit diagrams  
Components plans

**ROHDE & SCHWARZ**AZ Datum  
Date  
05 0686Schaltteilliste für  
Parts list for  
ZE AUSGANGSTEIL II  
OUTPUT STAGE IISachnummer  
Stock No.  
300.3560.00 SABlatt  
Page  
1

Kennzeichen Component No.	Benennung/Beschreibung Designation	Sachnummer Stock No.	enthalten in contained in
B1	BL SN74LS175N 4/D-FLIPFLO IC FLIP FLOP SN74LS175N TEXAS SN74LS175N	291.5048	300.5511
B2	BL SN74154N 1AUF16-DECOD. IC DECODER SN74154N TEXAS SN74154N	244.8509	300.5511
B3	BO LM124J 4XL.P.OPAMP OPERATIONAL AMPLIFIER NSC LM124J	BO 300.6353	300.5511
BIS/TO B7			
B8	BL SN74LS11N 3/3INP.AND IC AND GATE SN74LS11N TEXAS SN74LS11N	266.4135	300.5511
BU1	FP BUCHSE VERTIKAL P.V.1P SOCKET BERG 75377-001	FP 278.5577	300.5511
BIS/TO BU7			
BU12	FP BUCHSE VERTIKAL P.V.1P SOCKET BERG 75377-001	FP 278.5577	300.5511
BIS/TO BU27			
C1	CC 10NF-20+50%7X8R6000 CAPACITOR VALVO 2222 63051 64051103	CC 087.7525	300.5511
BIS/TO C8			
C13	CC 10NF-20+50%7X8R6000 CAPACITOR VALVO 2222 63051 64051103	CC 087.7525	300.5511
BIS/TO C17			
C20	CC 10NF-20+50%7X8R6000 CAPACITOR VALVO 2222 63051 64051103	CC 087.7525	300.5511
C30	CC 100PF+-2%6X7N150 CAPACITOR VALVO 2222 678 34101	CC 087.6712	300.5511
C31	CC 22PF+-2%3X4N150 CAPACITOR VALVO 2222 678 34229	CC 087.6635	300.5511
C32	CC 150PF+-2%6X9N150 CAPACITOR VALVO 2222 678 34151	CC 087.6735	300.5511
C33	CC 150PF+-2%6X9N150 CAPACITOR VALVO 2222 678 34151	CC 087.6735	300.5511
C34	CC 22PF+-2%3X4N150 CAPACITOR VALVO 2222 678 34229	CC 087.6635	300.5511
C35	CC 100PF+-2%6X7N150 CAPACITOR VALVO 2222 678 34101	CC 087.6712	300.5511

300.3560.00 SA BL 1+

Für diese Unterlage behalten wir  
uns alle Rechte vor



ROHDE & SCHWARZ

AZ Datum  
Date  
05 0686

Schaltteilliste für  
Parts list for  
ZE AUSGANGSTEIL II  
OUTPUT STAGE II

Sachnummer  
Stock No.  
300.3560.00 SA

Blatt  
Page  
2

Kennzeichen Component No.	Benennung/Beschreibung Designation	Sachnummer Stock No.	enthalten in contained in
C40	CC 82PF+-2%6X7N150 CAPACITOR VALVO 2222 678 34829	CC 087.6706	300.5511
C41	CC 10PF+-0,25PF3X4N150 CAPACITOR VALVO 2222 678 33109	CC 087.6593	300.5511
C42	CC 120PF+-2%6X9N150 CAPACITOR VALVO 2222 678 34121	CC 087.6729	300.5511
C43	CC 120PF+-2%6X9N150 CAPACITOR VALVO 2222 678 34121	CC 087.6729	300.5511
C44	CC 10PF+-0,25PF3X4N150 CAPACITOR VALVO 2222 678 33109	CC 087.6593	300.5511
C45	CC 82PF+-2%6X7N150 CAPACITOR VALVO 2222 678 34829	CC 087.6706	300.5511
C50	CC 56PF+-2%5X6N150 CAPACITOR VALVO 2222 678 34569	CC 087.6687	300.5511
C51	CC 82PF+-2%6X7N150 CAPACITOR VALVO 2222 678 34829	CC 087.6706	300.5511
C52	CC 82PF+-2%6X7N150 CAPACITOR VALVO 2222 678 34829	CC 087.6706	300.5511
C53	CC 56PF+-2%5X6N150 CAPACITOR VALVO 2222 678 34569	CC 087.6687	300.5511
C60	CC 150PF+-2%6X9N150 CAPACITOR VALVO 2222 678 34151	CC 087.6735	300.5511
C61	CC 120PF+-2%6X9N150 CAPACITOR VALVO 2222 678 34121	CC 087.6729	300.5511
BIS/TO C64 C65	CC 150PF+-2%6X9N150 CAPACITOR VALVO 2222 678 34151	CC 087.6735	300.5511
C70	CC 10NF-20+50%7X8R6000 CAPACITOR VALVO 2222 63051 64051103	CC 087.7525	300.5511
C80	CC 10NF-20+50%7X8R6000 CAPACITOR VALVO 2222 63051 64051103	CC 087.7525	300.5511
BIS/TO C83			
D1	LD 35DB/200M-10GHZ PI-FIL CHOKE ERIE 1214-038	LD 300.6818	300.5534
BIS/TO D7			

300.3560.00 SA BL 2+

**ROHDE & SCHWARZ**

AZ

Datum  
Date  
05 0686Schaltteilliste für  
Parts list for  
ZE AUSGANGSTEIL II  
OUTPUT STAGE IISachnummer  
Stock No.  
300.3560.00 SABlatt  
Page  
3Für diese Unterlage behalten wir  
uns alle Rechte vor

Kennzeichen Component No.	Benennung/Beschreibung Designation	Sachnummer Stock No.	enthalten in contained in
D12	LD 35DB/200M-10GHZ PI-FIL CHOKE ERIE 1214-038	LD 300.6818	300.5534
BIS/T0 D27			
GL30	AE 5082-3188 35V PINDI PIN DIODE HEWLETT-P. 5082-3188	AE 086.9118	300.5511
GL31	AE 5082-3188 35V PINDI PIN DIODE HEWLETT-P. 5082-3188	AE 086.9118	300.5511
GL32	AE 5082-3188 35V PINDI PIN DIODE HEWLETT-P. 5082-3188	AE 086.9118	300.5511
GL40	AE 5082-3188 35V PINDI PIN DIODE HEWLETT-P. 5082-3188	AE 086.9118	300.5511
GL41	AE 5082-3188 35V PINDI PIN DIODE HEWLETT-P. 5082-3188	AE 086.9118	300.5511
GL42	AE 5082-3188 35V PINDI PIN DIODE HEWLETT-P. 5082-3188	AE 086.9118	300.5511
GL50	AE 5082-3188 35V PINDI PIN DIODE HEWLETT-P. 5082-3188	AE 086.9118	300.5511
GL51	AE 5082-3188 35V PINDI PIN DIODE HEWLETT-P. 5082-3188	AE 086.9118	300.5511
GL52	AE 5082-3188 35V PINDI PIN DIODE HEWLETT-P. 5082-3188	AE 086.9118	300.5511
GL60	AE 5082-3188 35V PINDI PIN DIODE HEWLETT-P. 5082-3188	AE 086.9118	300.5511
GL61	AE 5082-3188 35V PINDI PIN DIODE HEWLETT-P. 5082-3188	AE 086.9118	300.5511
GL62	AE 5082-3188 35V PINDI PIN DIODE HEWLETT-P. 5082-3188	AE 086.9118	300.5511
L30	LD 0,22UH10%,140HM1,045A CHOKE DELEVAN DROSSEL1025-04	LD 067.2786	300.5511
L31	LD 0,27UH10%,160HM0,975A CHOKE DELEVAN DROSSEL1025-06	LD 067.2792	300.5511
L32	LD 0,22UH10%,140HM1,045A CHOKE DELEVAN DROSSEL1025-04	LD 067.2786	300.5511
L40	LD 0,15UH10%,100HM1,230A CHOKE DELEVAN DROSSEL1025-00	LD 067.2763	300.5511
		300.3560.00 SA	BL 3+



**ROHDE & SCHWARZ**

ÄZ	Datum
05	06 86

Schaltteilliste für Parts list for ZE AUSGANGS TEIL II OUTPUT STAGE II
---

Sachnummer Stock No.
300.3560.00 SA

Blatt Page
4

Kennzeichen Component No.	Benennung/Beschreibung Designation	Sachnummer Stock No.	enthalten in contained in
L41	LD 0,18UH10%,120HM1,120A CHOKE DELEVAN DROSSEL1025-02	LD 067.2770	300.5511
L42	LD 0,15UH10%,100HM1,230A CHOKE DELEVAN DROSSEL1025-00	LD 067.2763	300.5511
L50	LD 0,12UH10%,090HM1,300A CHOKE DELEVAN DROSSEL1025-96	LD 067.2757	300.5511
L51	LD 0,15UH10%,100HM1,230A CHOKE DELEVAN DROSSEL1025-00	LD 067.2763	300.5511
L52	LD 0,12UH10%,090HM1,300A CHOKE DELEVAN DROSSEL1025-96	LD 067.2757	300.5511
L60	LD 0,33UH10%,220HM0,830A CHOKE DELEVAN DROSSEL1025--08	LD 067.2805	300.5511
L61	LD 0,39UH10%,300HM0,710A CHOKE DELEVAN DROSSEL1025-10	LD 067.2811	300.5511
L62	LD 0,33UH10%,220HM0,830A CHOKE DELEVAN DROSSEL1025--08	LD 067.2805	300.5511
R2	RL 0,35W 3,92KOHM+-1%TK50 RESISTOR RESISTA MK2	RL 083.1039	300.5511
R3	RL 0,35W 1,50KOHM+-1%TK50 RESISTOR DRALORIC SMA0207/1,50K-F-D	RL 083.0732	300.5511
R4	RL 0,35W 47,5 OHM+-1%TK50 RESISTOR DRALORIC SMA0207/47,50HM-F-D	RL 082.9507	300.5511
R5	RL 0,35W 47,5 OHM+-1%TK50 RESISTOR DRALORIC SMA0207/47,50HM-F-D	RL 082.9507	300.5511
R6	RL 0,35W 47,5 OHM+-1%TK50 RESISTOR DRALORIC SMA0207/47,50HM-F-D	RL 082.9507	300.5511
R20	RL 0,21W 1,0KOHM2% UNGEW. RESISTOR RESISTA MK1 1K 2% UNGEW.	RL 092.6075	300.5511
R30	RL 0,21W 1,0KOHM2% UNGEW. RESISTOR RESISTA MK1 1K 2% UNGEW.	RL 092.6075	300.5511
BIS/TO R33 R70	RL 0,21W 1,0KOHM2% UNGEW. RESISTOR RESISTA MK1 1K 2% UNGEW.	RL 092.6075	300.5511
ST1	FP EINZELKONTAKTSTIFT SINGLE-CONTACT PIN ULMIC R&S.ZCHNG.300.8804	300.8804	300.5534

300.3560.00 SA BL 4+



ROHDE & SCHWARZ

ÄZ Datum  
Date  
05 0686

Schaltteilliste für  
Parts list for  
ZE AUSGANGSTEIL II  
OUTPUT STAGE II

Sachnummer  
Stock No.  
300.3560.00 SA

Blatt  
Page  
5

Kennzeichen Component No.	Benennung/Beschreibung Designation	Sachnummer Stock No.	enthalten in contained in
BIS/T0 ST7 ST12	FP EINZELKONTAKTSTIFT SINGLE-CONTACT PIN ULMIC R&S.ZCHNG.300.8804	300.8804	300.5534
BIS/T0 ST27 ST180	ENTHALTEN IN/INCLUDED IN LEITERPLATTE/PCB		300.5534
ST181	FJ EINBAUWINKELST. SMC ANGLE CONNECTOR RADIALL R 112 669	FJ 249.9684	300.5511
ST182	FJ EINBAUWINKELST. SMC ANGLE CONNECTOR RADIALL R 112 669	FJ 249.9684	300.5511
T1	AK BCY59IX NPN 45V 200MA TRANSISTOR SIEMENS BCY59IX	AK 010.5163	300.5511
T2	AK BCY79IX PNP 45V 200MA TRANSISTOR SIEMENS BCY79IX	AK 010.3777	300.5511
T3	AK BCY59IX NPN 45V 200MA TRANSISTOR SIEMENS BCY59IX	AK 010.5163	300.5511
T4	AK BCY79IX PNP 45V 200MA TRANSISTOR SIEMENS BCY79IX	AK 010.3777	300.5511
T5	AK BCY59IX NPN 45V 200MA TRANSISTOR SIEMENS BCY59IX	AK 010.5163	300.5511
T6	AK BCY79IX PNP 45V 200MA TRANSISTOR SIEMENS BCY79IX	AK 010.3777	300.5511
			- ENDE -

300.3560.00 SA BL 5-

Für diese Unterlage behalten wir  
uns alle Rechte vor

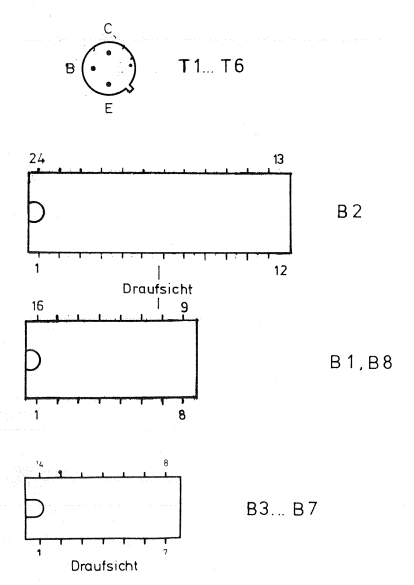
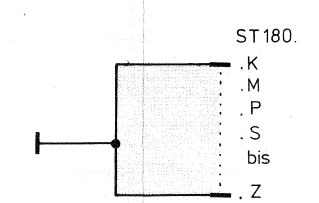
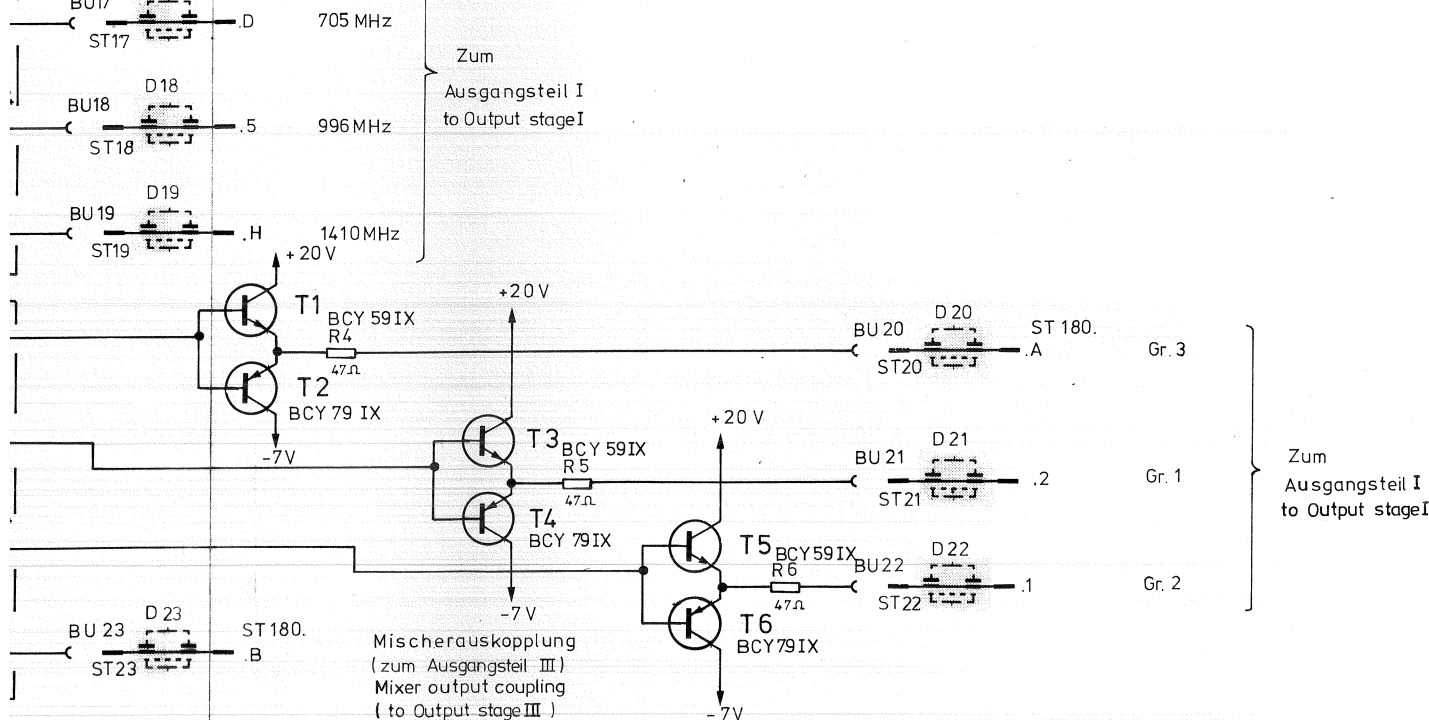
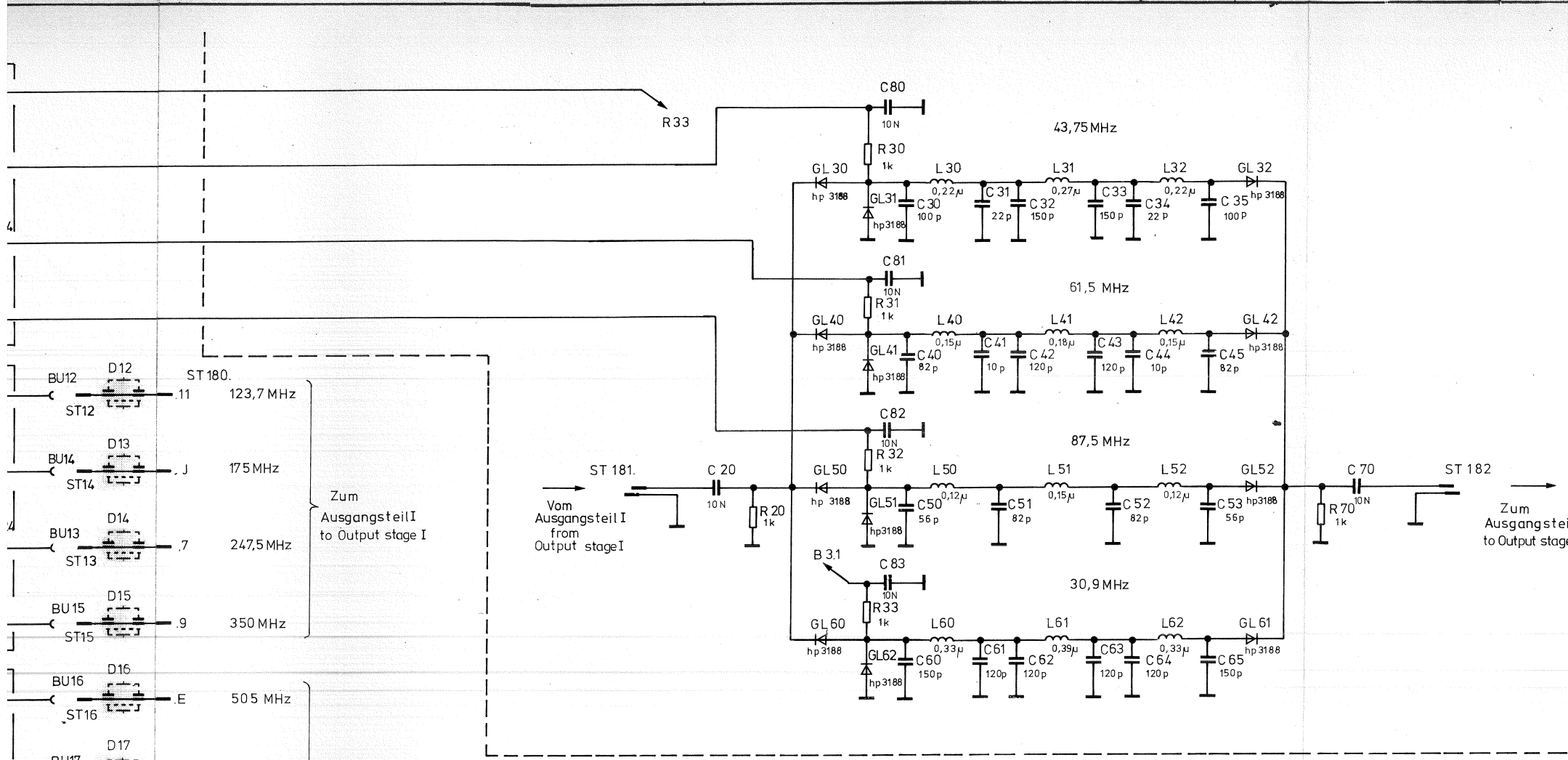

RECHNER W.A.R.		300.3560 S	
1GME		300.1000 V	300.1000
12.77	Sd	A — 10.78	Bg
2.80	Bg	B — 11.80	LS
Ausgangsteil II Output stage II			Z

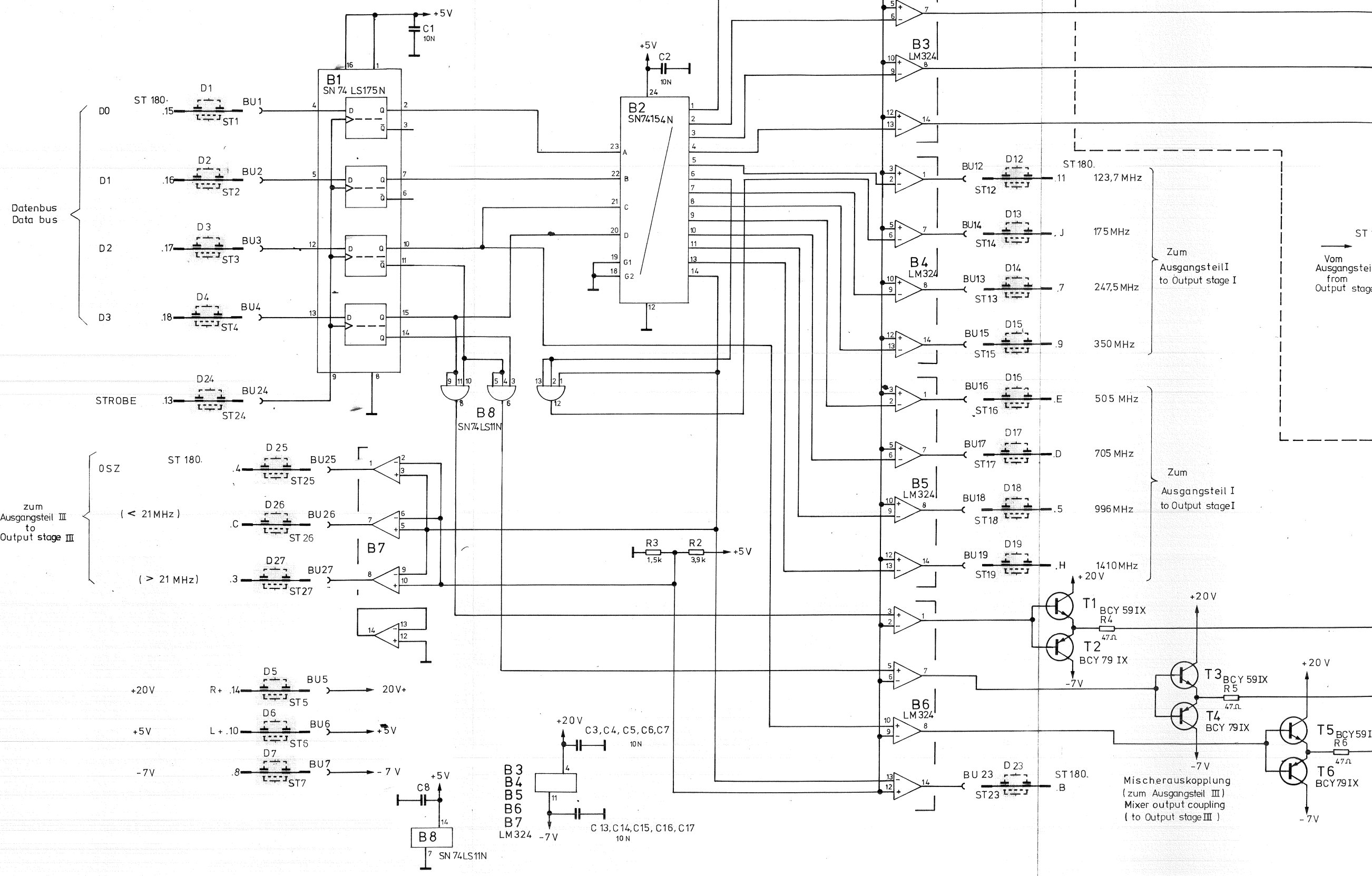

Datenbus  
Data bus

zum  
Ausgangsteil III  
to  
Output stage III

Zum  
Ausgangsteil I  
to Output stage I

Zum  
Ausgangsteil I  
to Output stage I

Mischerauskopplung  
(zum Ausgangsteil III)  
Mixer output coupling  
(to Output stage III)

Platte) Ausgangsteil II	300.5511
(B) Output stage II	
Führung Ausgangsteil II	300.5534
ed Output stage II	

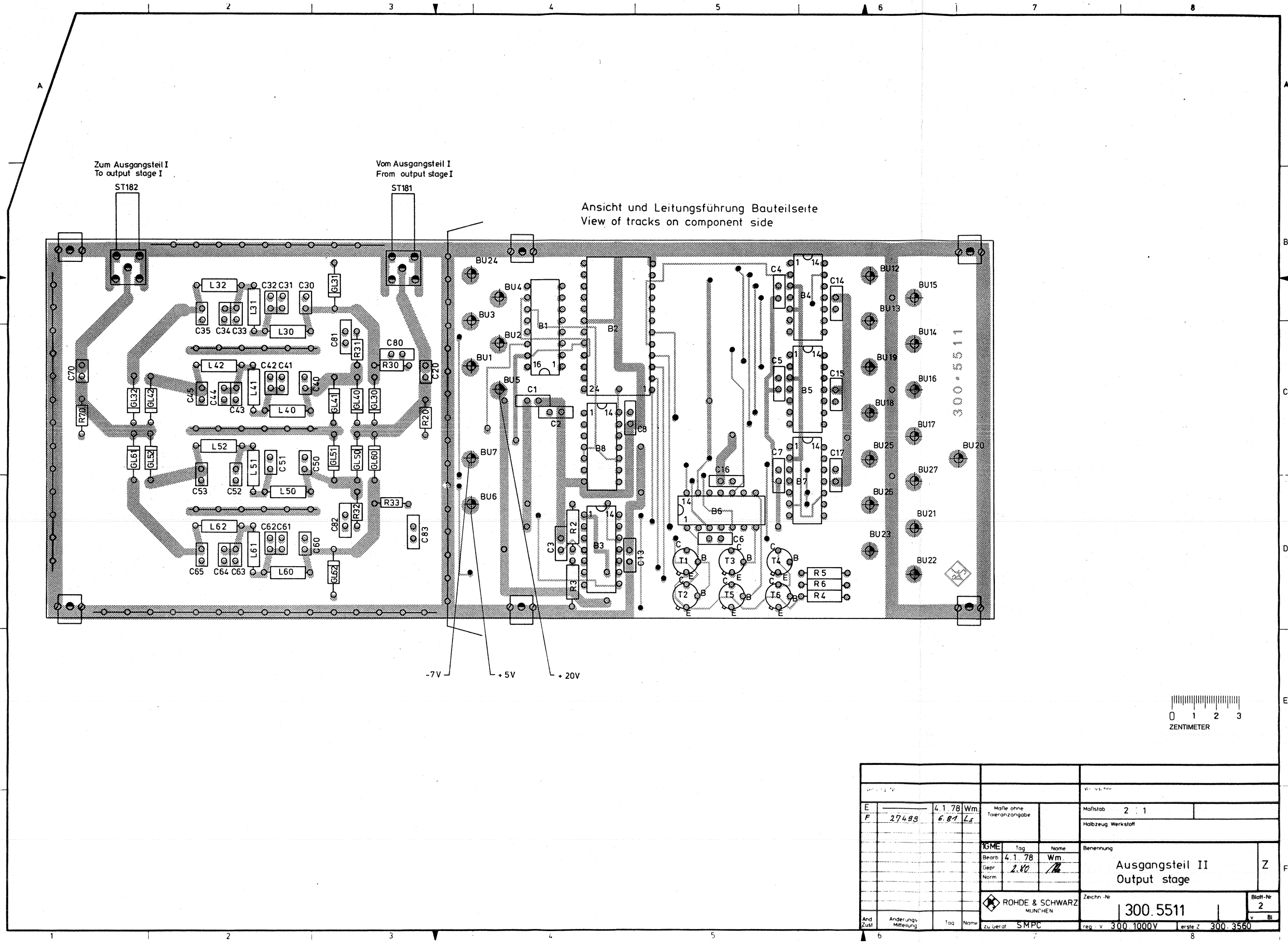

Ansicht und Leitungsführung Bauteilseite  
View of tracks on component side

Für diese Zeichnung behalten wir uns alle Rechte vor

E		4.1.78 Wm.		Maße ohne Toleranzangabe		Maßstab 2 : 1	
F		27493 6.81 Ls				Halbzeug Werkstoff	
		IGME Tag Name		Benennung			
		Bearb. 4.1.78 Wm.		Ausgangsteil II		Z	
		Gepr. 2.80		Output stage			
		Norm		ROHDE & SCHWARZ MÜNCHEN		Blatt-Nr 2	
And Zust		Anderungs-Mitteilung		Zu Verfert. SMPIC		reg. V 300.1000V erste Z 300.3560	
		Tag Name		Zeichn.-Nr 300.5511		v. Bl	



Ansicht und Leitungsführung Lötseite  
View of tracks on solder side

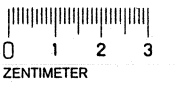
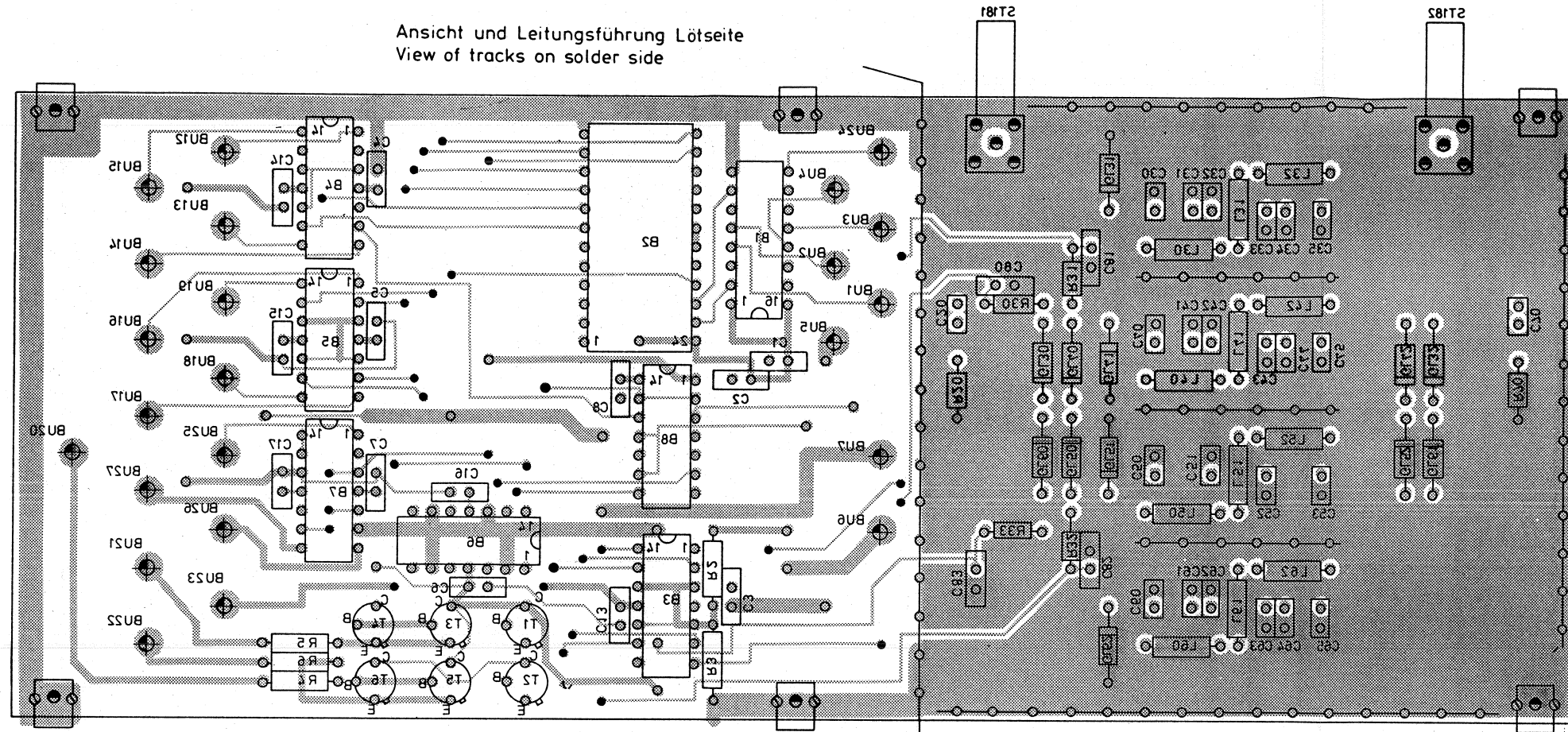

E		4.1.78	Wm.	Menge		Maststab 2 : 1	
F		27.4.88	Lz	Menge		Maststab	
				IGME		Herstellung	
				4.1.78		Ausgangsteil II	
				2.80		Output stage	
				ROHDE & SCHWARZ		Blatt Nr. 3	
				SMPC		300.5511	
				300.1000V		300.3560	

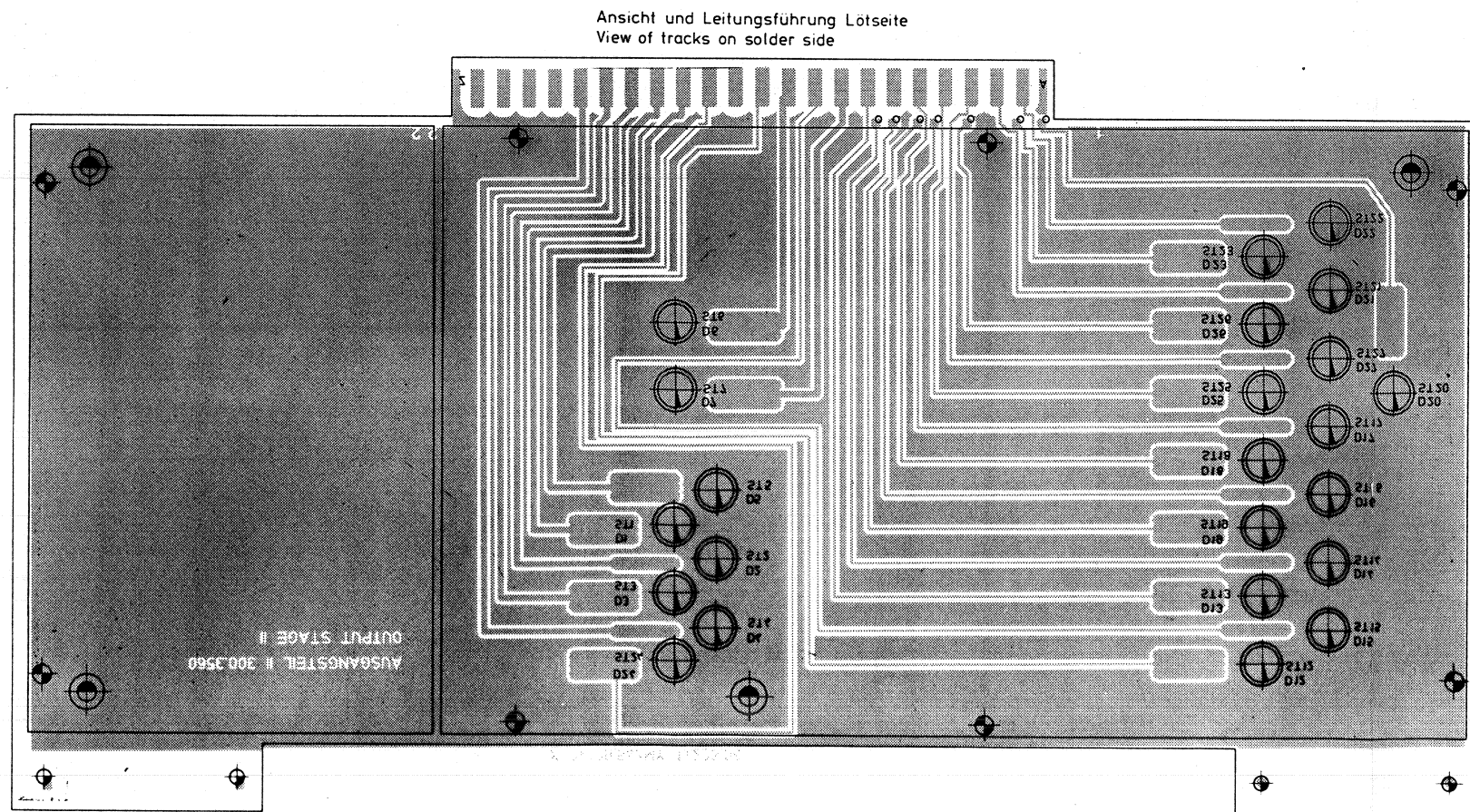
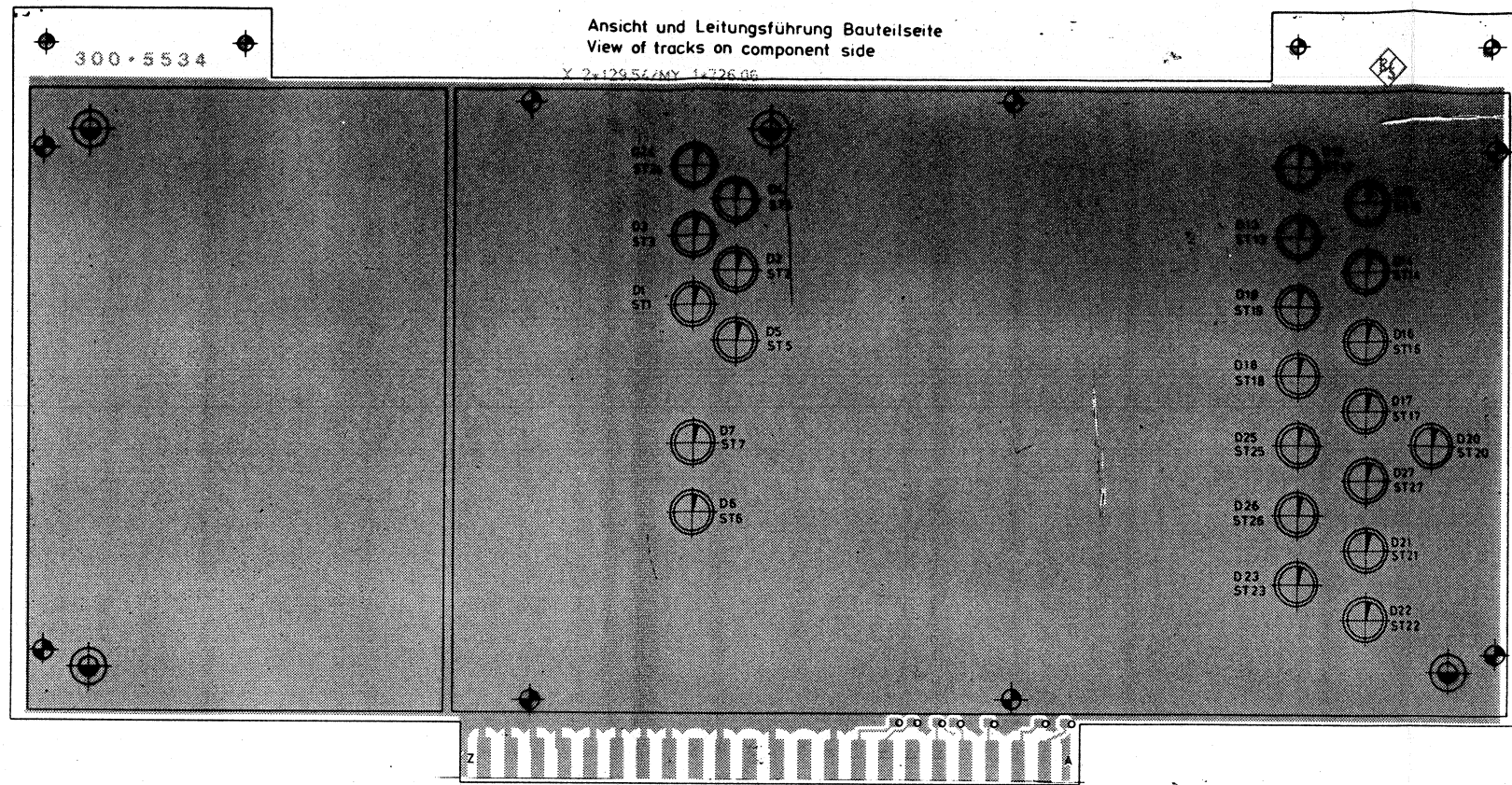

0 1 2 3  
ZENTIMETER

13.2.79	Wm	Mafie ohne Toleranzangabe	Mafistab: 2 : 1
			Halbzeug Werkstoff
RGME	Tag	Name	Benennung
Bepr: 13.2.79	Wm		Zuf-Ausgangsteil II
Gepr: 5.79	Wm		Feed output stage II
Norm:			
			Zechn.-Nr.
zu Gerät: SMPC			300.5534
reg. V. 300.1000V			erste Z. 300.3560
Blatt Nr. 2	v. Bl.		

Für diese Zeichnung behalten wir uns alle Rechte vor



**ROHDE & SCHWARZ**

SERVICE INSTRUCTIONS

Output Stage III

376.9318 (Y15)

Printed in West Germany



# Table of Contents

		Page
<u>5</u>	<u>Service Instructions for Output Stage III</u>	
	<u>376.9318 (Y15) .....</u>	<u>5.1</u>
5.1	Circuit Description .....	5.1
5.2	Checking and Adjustment Procedures .....	5.1
5.2.1	Checking the Transmission Loss .....	5.1
5.2.2	Checking the Rectifier Performance .....	5.2
5.2.2.1	Offset .....	5.2
5.2.2.2	Rectified Voltage .....	5.2
5.2.3	Checking the Mixer Range (<21,25 MHz) .....	5.2
5.2.4	Adjustment .....	5.2
5.2.4.1	Rectifier Offset .....	5.2
5.2.4.2	135-MHz Amplifier .....	5.2
5.2.4.3	Level in the Mixer Range .....	5.2
5.3	Troubleshooting .....	5.3
5.3.1	Nominal DC Voltages .....	5.3
5.3.2	Nominal RF Levels .....	5.3
5.3.3	Interfaces .....	5.4

Parts list  
Circuit diagram  
Components location plans

### 5.1 Circuit Description

(See circuit diagram 376.9318 S and Fig. 5-1)

Y15 comprises the mixer and amplifier for the frequency range 0.005 to 21.25 MHz and a diode switch that is required for switching over to the mixer range as well as three rectifiers which measure the 10-MHz reference level, the RF level in the divider and doubler range and the level of the mixer RF in the mixer range and deliver them to the control amplifier in Y12.

A series-connected 50- $\Omega$  resistor provided after the control test point ensures that the source impedance is correct.

In the switch position shown in Fig. 5-1 the signal from diode switch II (BU198) is applied directly to the output socket BU197. Rectifier GL now supplies the actual value of the level to the AGC amplifier in Y12.

In the mixer range the two switches changeover. The signal is applied from diode switch I (Y101) via ST196 and an attenuator to the RF input of the mixer B5 at the LO input of which the fixed frequency of 135 MHz from Y5 is present. GL7 now supplies the actual value to the control circuit in Y12. After filtering and amplification the mixer signal is applied to output ST197. Owing to the position of diode switch II, there is no signal present in the mixer range of BU198.

### 5.2 Checking and Adjustment Procedures

#### 5.2.1 Checking the Transmission Loss

Test setup:

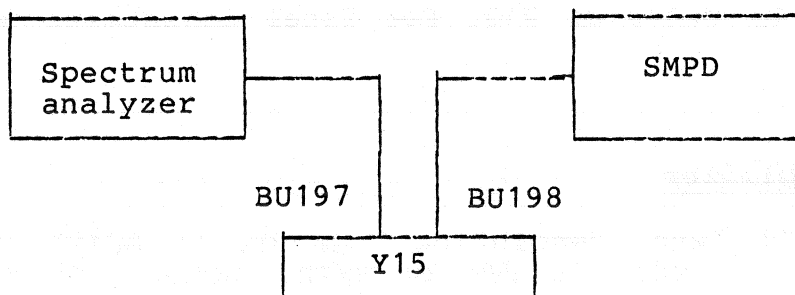

Settings on the SMPD: 13 dBm, 20 to 2720 MHz

The measured transmission loss must be below 7 dB over the total frequency range.

## 5.2.2 Checking the Rectifier Performance

### 5.2.2.1 Offset

Measure the DC voltages at BU194 and BU193 in the divider and in the mixer range without signal applied.

Nominal voltage: 220  $\pm$ 50 mV.

### 5.2.2.2 Rectified Voltage

Measure the DC voltages at BU194 and BU193 with an output level (BU197) of 13 dBm at frequencies from 0.05 to 1360 MHz.

Nominal voltage: 2.4  $\pm$ 0.1 V.

## 5.2.3 Checking the Mixer Range (< 21.25 MHz)

Feed 135.05 to 156.25 MHz with a level of 19  $\pm$ 0.5 dBm into ST196; harmonics < -36 dB. Feed 135.000 MHz with a level of 0  $\pm$ 1 dBm into ST191. Select mixer range. Connect RF analyzer or power meter to BU197. Vary R56 until level between 11.5  $\pm$ 1 and 14.5  $\pm$ 1 dBm is obtained from 0.05 to 21.25 MHz. The harmonic content should not exceed -30 dBc over the entire frequency range with an output level of 13 dBm. The frequency response should not exceed 0.4 dB relative to the signal fed into ST196.

## 5.2.4 Adjustment

### 5.2.4.1 Rectifier Offset

Measure DC voltage at BU193 in the divider range (< 21.25 MHz) without signal applied. After switching over to the mixer range adjust the same value by means of R13. For final adjustment see section 4.3.

### 5.2.4.2 135-MHz Amplifier

Connect RF analyzer with level resolution 1 dB/div to BU197 (or RF output socket). Set 20 MHz, 10 dBm on SMPD. Adjust C55 for maximum.

### 5.2.4.3 Level in the Mixer Range

For settings see section 4.3.

## 5.3 Troubleshooting

### 5.3.1 Nominal DC Voltages

	<21.25 MHz	>21.25 MHz	
BU1	18 ±1 V	-6 ±1 V	
MP1.1	12.5 ±1 V	-5.5 ±1 V	
MP3	220 ±50 mV	220 ±50 mV	without signal at ST196
	2.4 ±0.1 V	2.4 ±0.1 V	with 13 dBm output level
MP4	2.4 ±0.1 V	2.4 ±0.1 V	with 13 dBm output level
MP2.1	9.1 ±0.4 V		
MP2.2	9.1 ±0.4 V		without signal at ST196
MP5	7 ±0.5 V		

### 5.3.2 Nominal RF Levels

Setting 13 dBm. Measure with high-impedance probe.  
NOTE: DC coupling.

B5/8	135 MHz	7 ±1.5 dBm
B5/3.4	0.05 to 21.25 MHz	-13 ±1 dBm
MP2.2		- 4 ±1 dBm
MP2.1		7 ±1 dBm
MP5		19 ±1 dBm

### 5.3.3 Interfaces

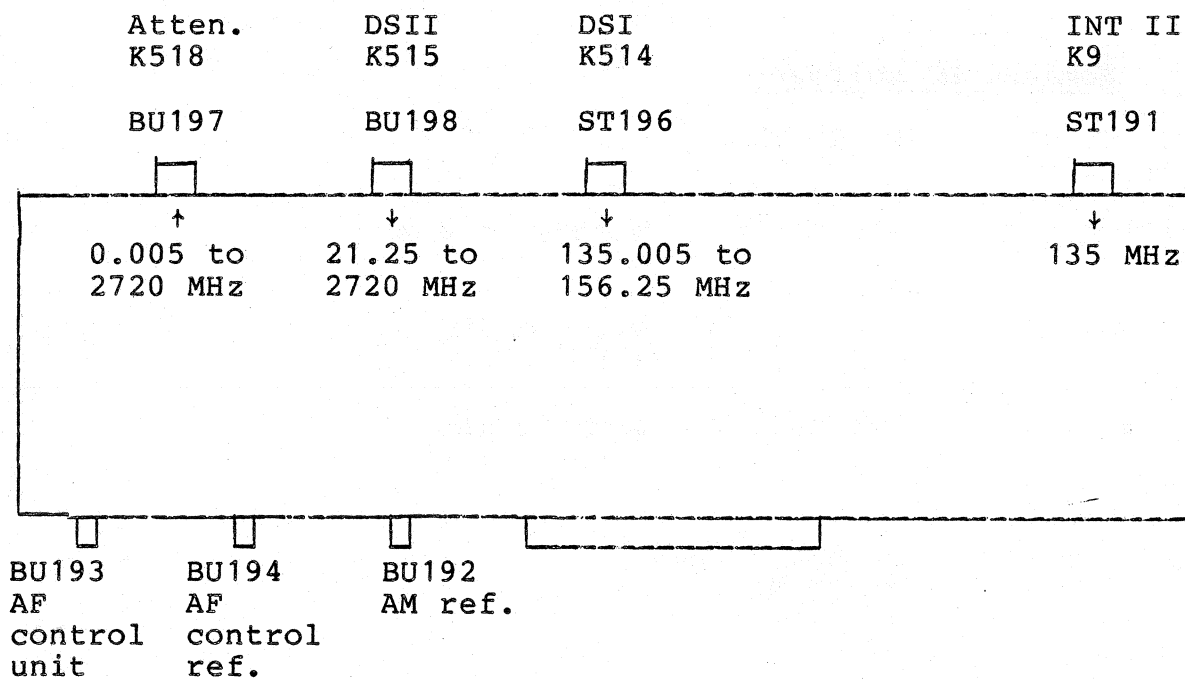

ST/BU	191	192	193	194
f	135 MHz	10 MHz	DC + AF	DC + AF
Level	0 ±1 dBm	up to 2 V <sub>rms</sub>	0.2 to 2.5 V	0.2 to 2.5V
R <sub>i</sub>	50 Ω	1 kΩ	0 Ω	0 Ω
AC-DC	AC	AC	DC	DC
Shape of curve	sinusoidal	sinusoidal	DC + AF	DC + AF

ST/BU	196	197	198
f	135.005 to 156.25 MHz	0.005 to 2720 MHz	21.25 to 2720 MHz
Level	19.5 to 21.5 dBm	up to 13 dBm	19 to 20 dBm
R <sub>i</sub>	50 Ω	50 Ω	50 Ω
AC-DC	AC	AC	AC
Shape of curve	sinusoidal	sinusoidal	sinusoidal

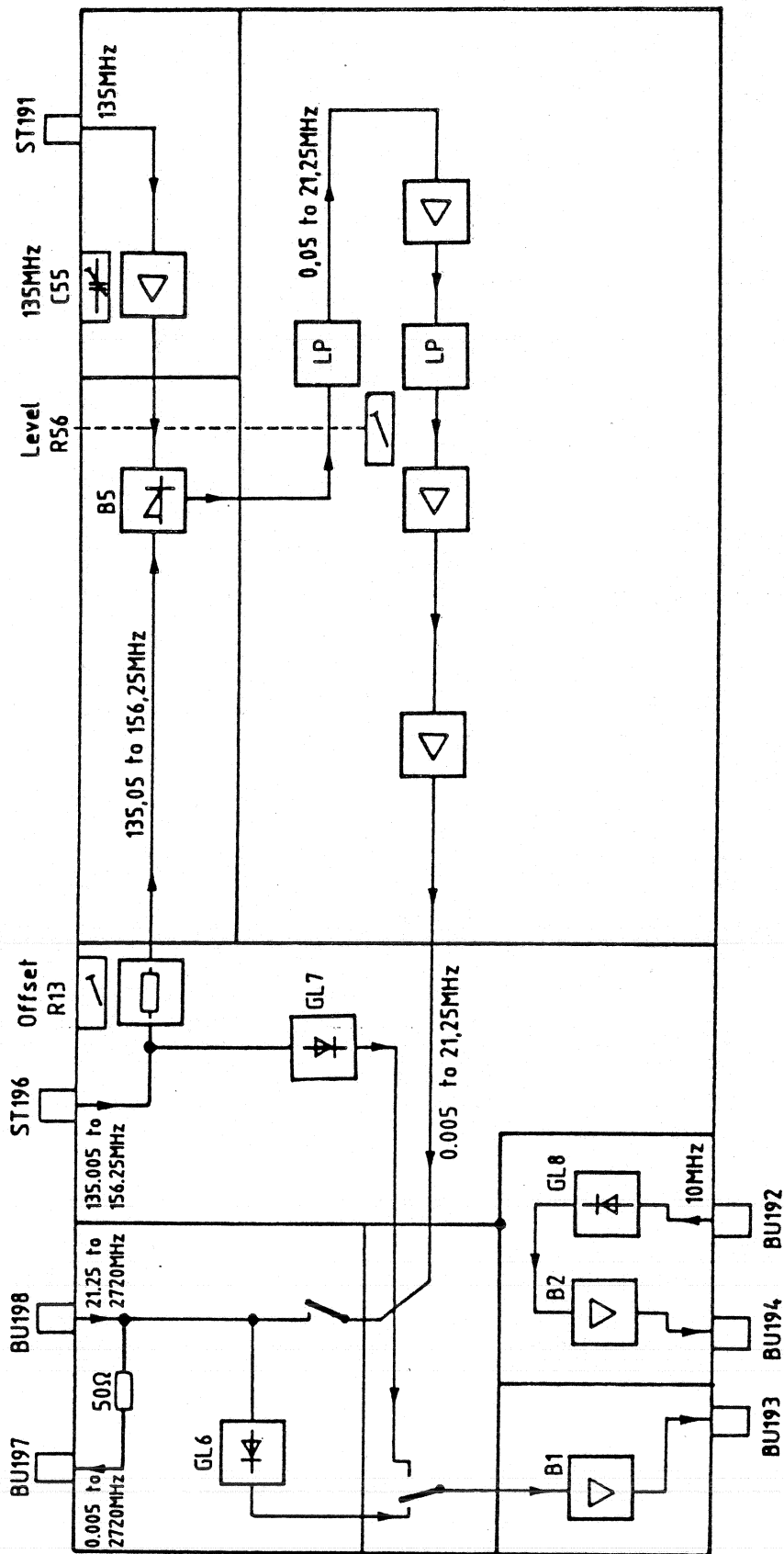

Fig. 5-1 Block diagram of output stage III



ROHDE & SCHWARZ  
MÜNCHEN

Schalteillisten  
Stromläufe  
Bestückungspläne  
Parts lists  
Circuit diagrams  
Components plans



Kennzeichen Component No.	Benennung/Beschreibung Designation	Sachnummer Stock No.	enthalten in contained in
B1	B0 LM210H VOLT.FOLLOW VOLTAGE FOLLOWER NSC LM210H	B0 300.9398	376.9324.01
B2	B0 LM210H VOLT.FOLLOW VOLTAGE FOLLOWER NSC LM210H	B0 300.9398	376.9324.01
B5	BM SRA1 MIXER 0.5GHZ MIXER MINI-CCTS SRA1	BM 207.3465	376.9324.01
BU1	FP BUCHSE VERTIKAL P.V.1P SOCKET BERG 75377-001	FP 278.5577	376.9324.01
BU2	FP BUCHSE VERTIKAL P.V.1P SOCKET BERG 75377-001	FP 278.5577	376.9324.01
BU4	FP BUCHSE VERTIKAL P.V.1P SOCKET BERG 75377-001	FP 278.5577	376.9324.01
BU5	FP BUCHSE VERTIKAL P.V.1P SOCKET BERG 75377-001	FP 278.5577	376.9324.01
BU192	FJ EINBAUBUCHSE SYST.SMS FIXED SOCKET RADIAL R.299 012	300.6876	
BU193	FJ EINBAUBUCHSE SYST.SMS FIXED SOCKET RADIAL R.299 012	300.6876	
BU194	FJ EINBAUBUCHSE SYST.SMS FIXED SOCKET RADIAL R.299 012	300.6876	
C7	CC 1NF+-10%63V K2000 CERAMIC CAPACITOR VALVO 2222 63051 102	CC 022.0784	376.9324.01
C8	CC 15PF+-2%3X4NPO CAPACITOR VALVO 2222 678 10159	CC 087.6441	376.9324.01
C9	CC 10NF-20+50%7X8R6000 CAPACITOR VALVO 2222 63051 64051103	CC 087.7525	376.9324.01
C15	CC 10NF-20+50%7X8R6000 CAPACITOR VALVO 2222 63051 64051103	CC 087.7525	376.9324.01
C16	CC 10NF-20+50%7X8R6000 CAPACITOR VALVO 2222 63051 64051103	CC 087.7525	376.9324.01
C17	CC 4,7NF+-10%6X9R2000 CAPACITOR VALVO 2222 63051 472	CC 087.7102	376.9324.01
C18	CC 15PF+-2%3X4NPO CAPACITOR VALVO 2222 678 10159	CC 087.6441	376.9324.01
C19	CC 10NF-20+50%7X8R6000 CAPACITOR VALVO 2222 63051 64051103	CC 087.7525	376.9324.01

Für diese Unterlage behalten wir  
uns alle Rechte vor



ROHDE & SCHWARZ

AZ Datum  
Date  
07 1185

Schaltteilliste für  
Parts list for  
AUSGANGSTEIL III  
OUTPUT STAGE III

Sachnummer  
Stock No.  
376.9318.01 SA

Blatt  
Page  
2

Kennzeichen Component No.	Benennung/Beschreibung Designation	Sachnummer Stock No.	enthalten in contained in
C20	CE 2,2UF+-20%20V 5X 4X 7 ELECTROLYTIC CAPACITOR ERO-TANTAL TA-ELKOETR-2,2/20	CE 022.8104	376.9324.01
C21	CE 2,2UF-10+50% 63V 9X13 ELECTROLYTIC CAPACITOR ROEDERST ELKO EK 2/63	CE 022.7637	376.9324.01
C22	CE 47 UF+-20% 6V 7X 5X11 ELECTROLYTIC CAPACITOR ERO-TANTAL TA/ELKOETR247/6	CE 022.8040	376.9324.01
C23	CC 10NF-20+50%7X8R6000 CAPACITOR VALVO 2222 63051 64051103	CC 087.7525	376.9324.01
C24	CE 47 UF+-20% 6V 7X 5X11 ELECTROLYTIC CAPACITOR ERO-TANTAL TA/ELKOETR247/6	CE 022.8040	376.9324.01
C25	CC 10NF-20+50%7X8R6000 CAPACITOR VALVO 2222 63051 64051103	CC 087.7525	376.9324.01
C26	CE 47 UF+-20% 6V 7X 5X11 ELECTROLYTIC CAPACITOR ERO-TANTAL TA/ELKOETR247/6	CE 022.8040	376.9324.01
C27	CC 10NF-20+50%7X8R6000 CAPACITOR VALVO 2222 63051 64051103	CC 087.7525	376.9324.01
C28	CC 10NF-20+50%7X8R6000 CAPACITOR VALVO 2222 63051 64051103	CC 087.7525	376.9324.01
C30	CE 100UF-10+50% 25V 13X13 ELECTROLYTIC CAPACITOR ROEDERST ELKOEK100/25	CE 208.4007	376.9324.01
C31	CC 10NF-20+50%7X8R6000 CAPACITOR VALVO 2222 63051 64051103	CC 087.7525	376.9324.01
C32	CE 4,7UF-10+50% 63V 9X13 ELECTROLYTIC CAPACITOR ROEDERST ELKOEK4/63	CE 022.7643	376.9324.01
C33	CE 1UF -10+50% 63V 9X13 ELECTROLYTIC CAPACITOR ROEDERST ELKO EK 1/63	CE 022.7620	376.9324.01
C34	CE 1UF -10+50% 63V 9X13 ELECTROLYTIC CAPACITOR ROEDERST ELKO EK 1/63	CE 022.7620	376.9324.01
C35	CE 22UF-10+50% 63V 9X13 ELECTROLYTIC CAPACITOR ROEDERST EK 00 CB 222 J	CE 006.7120	376.9324.01
C36	CE 2,2UF-10+50% 40V 9X13B ELECTROLYTIC CAPACITOR ROEDERST ELKO EKV 2/40	CE 086.4380	376.9324.01
C37	CE 4,7UF-10+50% 63V 9X13 ELECTROLYTIC CAPACITOR ROEDERST ELKOEK4/63	CE 022.7643	376.9324.01
C38	CE 4,7UF-10+50% 63V 9X13 ELECTROLYTIC CAPACITOR ROEDERST ELKOEK4/63	CE 022.7643	376.9324.01
C39	CE 4,7UF+-20%20V 7X 4X 8 ELECTROLYTIC CAPACITOR ERO-TANTAL TA-ELKOETR2-4,7/20	CE 022.8110	376.9324.01

376.9318.01 SA BL 2+



ROHDE & SCHWARZ

ÄZ Datum  
Date  
07 1185

Schaltteilliste für  
Parts list for  
AUSGANGSTEIL III  
OUTPUTSTAGE III

Sachnummer  
Stock No.  
376.9318.01 SA

Blatt  
Page  
3

Kennzeichen Component No.	Benennung/Beschreibung Designation	Sachnummer Stock No.	enthalten in contained in
C40	CC 10NF-20+50%7X8R6000 CAPACITOR VALVO 2222 63051 64051103	CC 087.7525	376.9324.01
C41	CC 12PF+-2%3X4NPO CAPACITOR VALVO 2222 678 10129	CC 087.6435	376.9324.01
C45	CC 10NF-20+50%7X8R6000 CAPACITOR VALVO 2222 63051 64051103	CC 087.7525	376.9324.01
C47	CE 1UF -10+50% 63V 9X13 ELECTROLYTIC CAPACITOR ROEDERST ELKO EK 1/63	CE 022.7620	376.9324.01
C48	CE 4,7UF+-20%20V 7X 4X 8 ELECTROLYTIC CAPACITOR ERO-TANTAL TA-ELKOETR2-4,7/20	CE 022.8110	376.9324.01
C49	CC 82PF+-2%6X7NPO CAPACITOR VALVO 2222 678 10829	CC 087.6535	376.9324.01
C50	CC 33PF+-2%4X5NPO CAPACITOR VALVO 2222 678 10339	CC 087.6487	376.9324.01
C52	CK 1UF+-10%50V5RM MKT CAPACITOR WIMA MKS2/50/1UF/10%	CK 099.2998	376.9324.01
C53	CC 3,3NF+-10%6X7R2000 CAPACITOR VALVO 2222 63051 332	CC 087.7083	376.9324.01
C54	CC 15PF+-2%3X4NPO CAPACITOR VALVO 2222 678 10159	CC 087.6441	376.9324.01
C55	CT 9,5 PF N470 ABGL.301 TRIMMER STETTNER 7S-TRIK013/3,5/13N47	CT 065.9683	376.9324.01
C56	CC 1NF+-10%63V K2000 CERAMIC CAPACITOR VALVO 2222 63051 102	CC 022.0784	376.9324.01
C57	CC 3,3NF+-10%6X7R2000 CAPACITOR VALVO 2222 63051 332	CC 087.7083	376.9324.01
C58	CC 1NF+-10%63V K2000 CERAMIC CAPACITOR VALVO 2222 63051 102	CC 022.0784	376.9324.01
C59	CC 68PF+-2%6X7NPO CAPACITOR VALVO 2222 678 10689	CC 087.6529	376.9324.01
C60	CC 220PF+-2%6X7N750 CAPACITOR VALVO 2222 678 58221	CC 087.6941	376.9324.01
C61	CC 150PF+-2%5X6N750 CAPACITOR VALVO 2222 678 58151	CC 087.6929	376.9324.01
C62	CE 4,7UF+-20%20V 7X 4X 8 ELECTROLYTIC CAPACITOR ERO-TANTAL TA-ELKOETR2-4,7/20	CE 022.8110	376.9324.01
C63	CE 100UF-10+50% 16V 9X13 ELECTROLYTIC CAPACITOR ROEDERST EK 00CB 310 D	CE 006.7165	376.9324.01

376.9318.01 SA BL 3+

Für diese Unterlage behalten wir  
uns alle Rechte vor

Kennzeichen Component No.	Benennung/Beschreibung Designation	Sachnummer Stock No.	enthalten in contained in
C64	CC 10NF-20+50%7X8R6000 CAPACITOR VALVO 2222 63051 64051103	CC 087.7525	376.9324.01
C65	CC 6,8PF+-0,25PF3X4NPO CAPACITOR VALVO 2222 678 09688	CC 087.6406	376.9324.01
C66	CC 4,7NF+-10%6X9R2000 CAPACITOR VALVO 2222 63051 472	CC 087.7102	376.9324.01
D1	LD 35DB/200M-10GHZ PI-FIL CHOKE ERIE 1214-038	LD 300.6818	376.9376.01
D2	LD 35DB/200M-10GHZ PI-FIL CHOKE ERIE 1214-038	LD 300.6818	376.9376.01
D4	LD 35DB/200M-10GHZ PI-FIL CHOKE ERIE 1214-038	LD 300.6818	376.9376.01
D5	LD 35DB/200M-10GHZ PI-FIL CHOKE ERIE 1214-038	LD 300.6818	376.9376.01
GL7	AE BAT16-046 SCHOTTKYDI SCHOTTKY DIODE SIEMENS BAT16-046	395.2850	376.9324.01
GL8	AE BAT16-046 SCHOTTKYDI SCHOTTKY DIODE SIEMENS BAT16-046	395.2850	376.9324.01
GL9	AD 1N4448 75V 0,15A UDI DIODE VALVO 1N4448	AD 012.0700	376.9324.01
GL10	AD 1N4448 75V 0,15A UDI DIODE VALVO 1N4448	AD 012.0700	376.9324.01
GL17	AD 1N4448 75V 0,15A UDI DIODE VALVO 1N4448	AD 012.0700	376.9324.01
GL20	AD 1N4448 75V 0,15A UDI DIODE VALVO 1N4448	AD 012.0700	376.9324.01
GL21	AD 1N4448 75V 0,15A UDI DIODE VALVO 1N4448	AD 012.0700	376.9324.01
GL22	AD 1N4448 75V 0,15A UDI DIODE VALVO 1N4448	AD 012.0700	376.9324.01
L1	LD SPULE COIL	337.8208	376.9324.01
L2	LD SPULE 1,5MH COIL	300.6682	376.9324.01
L4	LD SPULE 1,5MH COIL	300.6682	376.9324.01
L5	LD 120 UH10%13,0OHMO,066A CHOKE DELEVAN DROSSEL1025-70	LD 067.3118	376.9324.01



RONDE & SCHWARZ

ÄZ Datum  
Date 07 1185

Schalteilliste für  
Parts list for  
AUSGANGSTEIL III  
OUTPUTSTAGE III

Sachnummer  
Stock No. 376.9318.01 SA

Blatt  
Page 5

Kennzeichen Component No.	Benennung/Beschreibung Designation	Sachnummer Stock No.	enthalten in contained in
L6	LD 120 UH10%13,00HMO,066A CHOKE	LD 067.3118	376.9324.01
L7	DELEVAN DROSSEL1025-70 LD 220 UH10%21,00HMO,052A CHOKE	LD 067.3147	376.9324.01
L10	DELEVAN DROSSEL1025-76 LD 0,33UH10%0,220HMO,830A CHOKE	LD 067.2805	376.9324.01
L11	DELEVAN DROSSEL1025--08 LD 0,82UH10%0,850HMO,420A CHOKE	LD 067.2857	376.9324.01
L12	DELEVAN DROSSEL1025-18 LD 1,50UH10%0,220HMO,560A CHOKE	LD 067.2886	376.9324.01
L14	DELEVAN DROSSEL 1025-24 LD 0,18UH10%0,120HM1,120A CHOKE	LD 067.2770	376.9324.01
L15	DELEVAN DROSSEL1025-02 LD 0,39UH10%0,300HMO,710A CHOKE	LD 067.2811	376.9324.01
L16	DELEVAN DROSSEL1025-10 LD 0,15UH10%0,100HM1,230A CHOKE	LD 067.2763	376.9324.01
L17	DELEVAN DROSSEL1025-00 LD 1,50UH10%0,220HMO,560A CHOKE	LD 067.2886	376.9324.01
L18	DELEVAN DROSSEL 1025-24 LL SPULE	300.6676	376.9324.01
L19	COIL LL SPULE	300.6599	376.9324.01
L20	COIL LD 15,0UH10%2,800HMO,157A CHOKE	LD 067.3001	376.9324.01
MP1	DELEVAN DROSSEL1025-48 VL WIRE-WRAP PIN BERG NR. 75 403-001	VL 088.4507	376.9324.01
BIS/TO MP5			
R3	RL 0,35W 68,1KOHM+-1%TK50 RESISTOR	RL 082.2602	376.9324.01
R5	DRALORIC SMA 0207/68,1K-F-C RL 0,35W 2,21KOHM+-1%TK50 RESISTOR	RL 082.2477	376.9324.01
R10	DRALORIC SMA 0207/2,21K-F-C RL 0,21W 1,0KOHM2% UNGEW. RESISTOR	RL 092.6075	376.9324.01
R11	RESISTA MK1 1K 2% UNGEW. RL 0,35W 68,1KOHM+-1%TK50 RESISTOR	RL 082.2602	376.9324.01
R12	DRALORIC SMA 0207/68,1K-F-C RL 0,35W 2,00KOHM+-1%TK50 RESISTOR	RL 083.0826	376.9324.01
	DRALORIC SMA0207/2,00K-F-D		

376.9318.01 SA BL 5+

Für diese Unterlage behalten wir  
uns alle Rechte vor



ROHDE & SCHWARZ

ÄZ Datum  
Date  
07 1185

Schaltteilliste für  
Parts list for  
AUSGANGSTEIL III  
OUTPUTSTAGE III

Sachnummer  
Stock No.  
376.9318.01 SA

Blatt  
Page  
6

Kennzeichen Component No.	Benennung/Beschreibung Designation	Sachnummer Stock No.	enthalten in contained in
R13	RS 0,5W500 OHM+-10%10X10X CERMET POTENTIOMETER BOURNS 3386X-1-501	RS 247.7955	376.9324.01
R14	RL 0,35W 22,1KOHM+-1%TK50 RESISTOR DRALORIC SMA/207/22,1K-F-C	RL 083.1545	376.9324.01
R16	RL 0,35W 1KOHM+-1%TK50 RESISTOR DRALORIC SMA0207/1K-F-C	RL 082.2160	376.9324.01
R17	RL 0,35W 4,75KOHM+-1%TK50 RESISTOR DRALORIC SMA0207/4,75K-F-D	RL 083.1097	376.9324.01
R19	RL 0,35W 68,1KOHM+-1%TK50 RESISTOR DRALORIC SMA 0207/68,1K-F-C	RL 082.2602	376.9324.01
R20	RL 0,35W 2,21KOHM+-1%TK50 RESISTOR DRALORIC SMA 0207/2,21K-F-C	RL 082.2477	376.9324.01
R21	RL 0,35W 1KOHM+-1%TK50 RESISTOR DRALORIC SMA0207/1K-F-C	RL 082.2160	376.9324.01
R22	RL 0,35W 22,1KOHM+-1%TK50 RESISTOR DRALORIC SMA/207/22,1K-F-C	RL 083.1545	376.9324.01
R30	RL 0,35W 68,1 OHM+-1%TK50 RESISTOR DRALORIC SMA0207/68,10HM-F-D	RL 082.9636	376.9324.01
R31	RL 0,35W 3,32KOHM+-1%TK50 RESISTOR DRALORIC SMA0207/3,32K-F-D	RL 083.0990	376.9324.01
R32	RL 0,35W 39,2 OHM+-1%TK50 RESISTOR DRALORIC SMA0207/39,20HM-F-D	RL 082.9420	376.9324.01
R33	RL 0,35W 475 OHM+-1%TK50 RESISTOR DRALORIC SMA0207/4750HM-F-D	RL 083.0390	376.9324.01
R34	RL 0,35W 10,0KOHM+-1%TK50 RESISTOR DRALORIC SMA0207/10K-F-D	RL 083.1297	376.9324.01
R35	RL 0,35W 10,0KOHM+-1%TK50 RESISTOR DRALORIC SMA0207/10K-F-D	RL 083.1297	376.9324.01
R36	RL 0,35W 3,32KOHM+-1%TK50 RESISTOR DRALORIC SMA0207/3,32K-F-D	RL 083.0990	376.9324.01
R37	RL 0,35W 68,1 OHM+-1%TK50 RESISTOR DRALORIC SMA0207/68,10HM-F-D	RL 082.9636	376.9324.01
R38	RL 0,35W 121 OHM+-1%TK50 RESISTOR DRALORIC SMA0207/1210HM-F-D	RL 082.9859	376.9324.01
R45	RL 0,35W 182 OHM+-1%TK50 RESISTOR DRALORIC SMA0207/1820HM-F-D	RL 083.0010	376.9324.01
R46	RL 0,35W 182 OHM+-1%TK50 RESISTOR DRALORIC SMA0207/1820HM-F-D	RL 083.0010	376.9324.01

376.9318.01 SA BL 6+



ROHDE &amp; SCHWARZ

 AZ Datum  
 Date  
 07 1185

 Schalteilliste für  
 Parts list for  
 AUSGANGSTEIL III  
 OUTPUTSTAGE III

 Sachnummer  
 Stock No.  
 376.9318.01 SA

 Blatt  
 Page  
 7

Kennzeichen Component No.	Benennung/Beschreibung Designation	Sachnummer Stock No.	enthalten in contained in
R47	RL 0,35W 681 OHM+-1%TK50 RESISTOR DRALORIC SMA0207/681OHM-F-D	RL 083.0490	376.9324.01
R48	RL 0,35W 681 OHM+-1%TK50 RESISTOR DRALORIC SMA0207/681OHM-F-D	RL 083.0490	376.9324.01
R49	RL 0,35W 100 OHM+-1%TK50 DEPOS.-CARBON RESISTOR DRALORIC SMA0207/100/HM-F-D	RL 082.6543	376.9324.01
R50	RL 0,35W 100 OHM+-1%TK50 DEPOS.-CARBON RESISTOR DRALORIC SMA0207/100/HM-F-D	RL 082.6543	376.9324.01
R51	RL 0,35W 100 OHM+-1%TK50 DEPOS.-CARBON RESISTOR DRALORIC SMA0207/100/HM-F-D	RL 082.6543	376.9324.01
R52	RL 0,35W 182 OHM+-1%TK50 RESISTOR DRALORIC SMA0207/182OHM-F-D	RL 083.0010	376.9324.01
R53	RL 0,35W 182 OHM+-1%TK50 RESISTOR DRALORIC SMA0207/182OHM-F-D	RL 083.0010	376.9324.01
R54	RL 0,35W 681 OHM+-1%TK50 RESISTOR DRALORIC SMA0207/681OHM-F-D	RL 083.0490	376.9324.01
R55	RL 0,35W 681 OHM+-1%TK50 RESISTOR DRALORIC SMA0207/681OHM-F-D	RL 083.0490	376.9324.01
R56	RS 0,5W100 OHM+-10%10X10X CERMET POTENTIOMETER BOURNS 3386X-1-101	RS 247.7932	376.9324.01
R57	RL 0,35W 47,5 OHM+-1%TK50 RESISTOR DRALORIC SMA0207/47,5OHM-F-D	RL 082.9507	376.9324.01
R58	RL 0,35W 47,5 OHM+-1%TK50 RESISTOR DRALORIC SMA0207/47,5OHM-F-D	RL 082.9507	376.9324.01
R59	RL 0,35W 10,0 OHM+-1%TK50 RESISTOR DRALORIC SMA0207/10OHM-F-D	RL 082.8852	376.9324.01
R65	RL 0,35W 47,5 OHM+-1%TK50 RESISTOR DRALORIC SMA0207/47,5OHM-F-D	RL 082.9507	376.9324.01
R66	RL 0,35W 825 OHM+-1%TK50 RESISTOR DRALORIC SMA 0207/825OHM-F-C	RL 082.2502	376.9324.01
R70	RL 0,35W 47,5 OHM+-1%TK50 RESISTOR DRALORIC SMA0207/47,5OHM-F-D	RL 082.9507	376.9324.01
R71	RL 0,21W 56 OHM2% UNGEW. RESISTOR RESISTA MK1 56OHM 2% UNGEW.	RL 092.5927	376.9324.01
R72	RL 0,21W 470 OHM2% UNGEW. RESISTOR RESISTA MK1 470OHM 2% UNGEW.	RL 092.6030	376.9324.01
R73	RL 0,21W 180 OHM2% UNGEW. RESISTOR RESISTA MK1 180OHM 2% UNGEW.	RL 092.5985	376.9324.01

376.9318.01 SA BL 7+

Für diese Unterlage behalten wir  
uns alle Rechte vor



**ROHDE & SCHWARZ**

ÄZ	Datum
07	1185

Schaltteilliste für	Parts list for
AUSGANGSTEIL III	
OUTPUTSTAGE III	

Sachnummer	Stock No.
376.9318.01 SA	

Blatt	Page
8	

Kennzeichen Component No.	Benennung/Beschreibung Designation	Sachnummer Stock No.	enthalten in contained in
R74	RL 0,21W 180 OHM2% UNGEW. RESISTOR RESISTA MK1 180OHM 2% UNGEW.	RL 092.5985	376.9324.01
R82	RL 0,21W 100 OHM2% UNGEW. RESISTOR RESISTA MK1 100OHM 2% UNGEW.	RL 092.5956	376.9324.01
R83	RL 0,21W 100 OHM2% UNGEW. RESISTOR RESISTA MK1 100OHM 2% UNGEW.	RL 092.5956	376.9324.01
RS1	SN 12V 1XU AU-CO MONOSTAB RELAY SDS RS-12V	SN 063.7083	376.9324.01
ST1	FP EINZELKONTAKTSTIFT SINGLE-CONTACT PIN ULMIC R&S.ZCHNG.300.8804	300.8804	376.9376.01
ST2	FP EINZELKONTAKTSTIFT SINGLE-CONTACT PIN ULMIC R&S.ZCHNG.300.8804	300.8804	376.9376.01
ST4	FP EINZELKONTAKTSTIFT SINGLE-CONTACT PIN ULMIC R&S.ZCHNG.300.8804	300.8804	376.9376.01
ST5	FP EINZELKONTAKTSTIFT SINGLE-CONTACT PIN ULMIC R&S.ZCHNG.300.8804	300.8804	376.9376.01
ST190	ENTHALTEN IN/INCLUDED IN LEITERPLATTE/PCB		376.9376.01
ST191	FJ EINBAUWINKELST. SMC ANGLE CONNECTOR RADIALL R 112 669	FJ 249.9684	376.9324.01
ST196	FJ EINBAUWINKELST. SMC ANGLE CONNECTOR RADIALL R 112 669	FJ 249.9684	376.9324.01
T1	AK BCY59IX NPN 45V 200MA TRANSISTOR SIEMENS BCY59IX	AK 010.5163	376.9324.01
T10	AK 2N2369A NPN 15V 200MA TRANSISTOR VALVO 2N2369A	AK 010.4680	376.9324.01
T11	AK 2N3209 PNP 20V 100MA TRANSISTOR SGS 2N3209	AK 010.3590	376.9324.01
T12	AK 2N3209 PNP 20V 100MA TRANSISTOR SGS 2N3209	AK 010.3590	376.9324.01
T13	AK 2N2369A NPN 15V 200MA TRANSISTOR VALVO 2N2369A	AK 010.4680	376.9324.01
T14	AK 2N2369A NPN 15V 200MA TRANSISTOR VALVO 2N2369A	AK 010.4680	376.9324.01
T15	AK 2N2369A NPN 15V 200MA TRANSISTOR VALVO 2N2369A	AK 010.4680	376.9324.01

376.9318.01 SA BL 8+



ROHDE & SCHWARZ

ÄZ Datum  
Date  
07 1185

Schaltteilliste für  
Parts list for  
AUSGANGSTEIL III  
OUTPUTSTAGE III

Sachnummer  
Stock No.  
376.9318.01 SA

Blatt  
Page  
9

Kennzeichen Component No.	Benennung/Beschreibung Designation	Sachnummer Stock No.	enthalten in contained in
T16	AK 2N2369A NPN 15V 200MA TRANSISTOR VALVO 2N2369A	AK 010.4680	376.9324.01
T17	AK BFT66 NPN 15V >3GHZ TRANSISTOR SIEMENS BFT66	AK 252.5728	376.9324.01
T18	AK 2N2369A NPN 15V 200MA TRANSISTOR VALVO 2N2369A	AK 010.4680	376.9324.01
Y115	BD PEGELDETEKTOR	914.8607	- ENDE -

Für diese Unterlage behalten wir  
uns alle Rechte vor

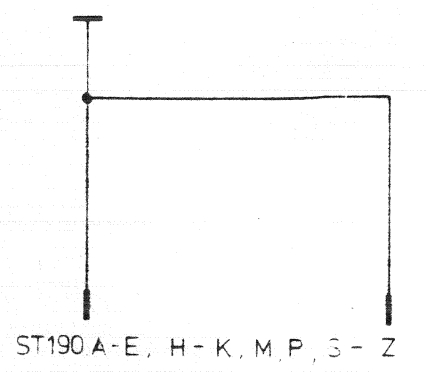
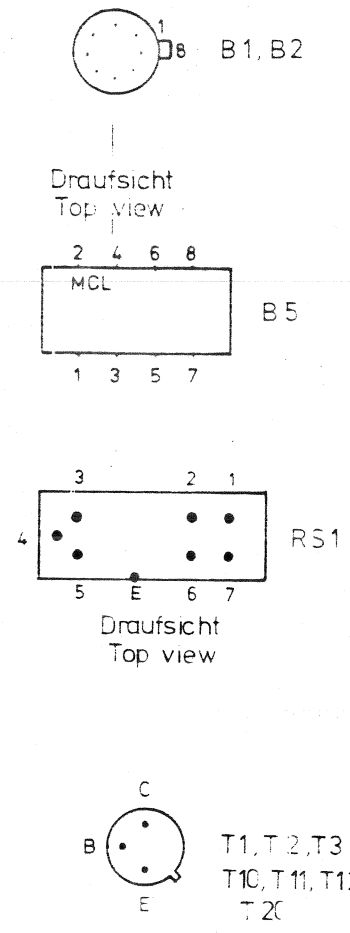
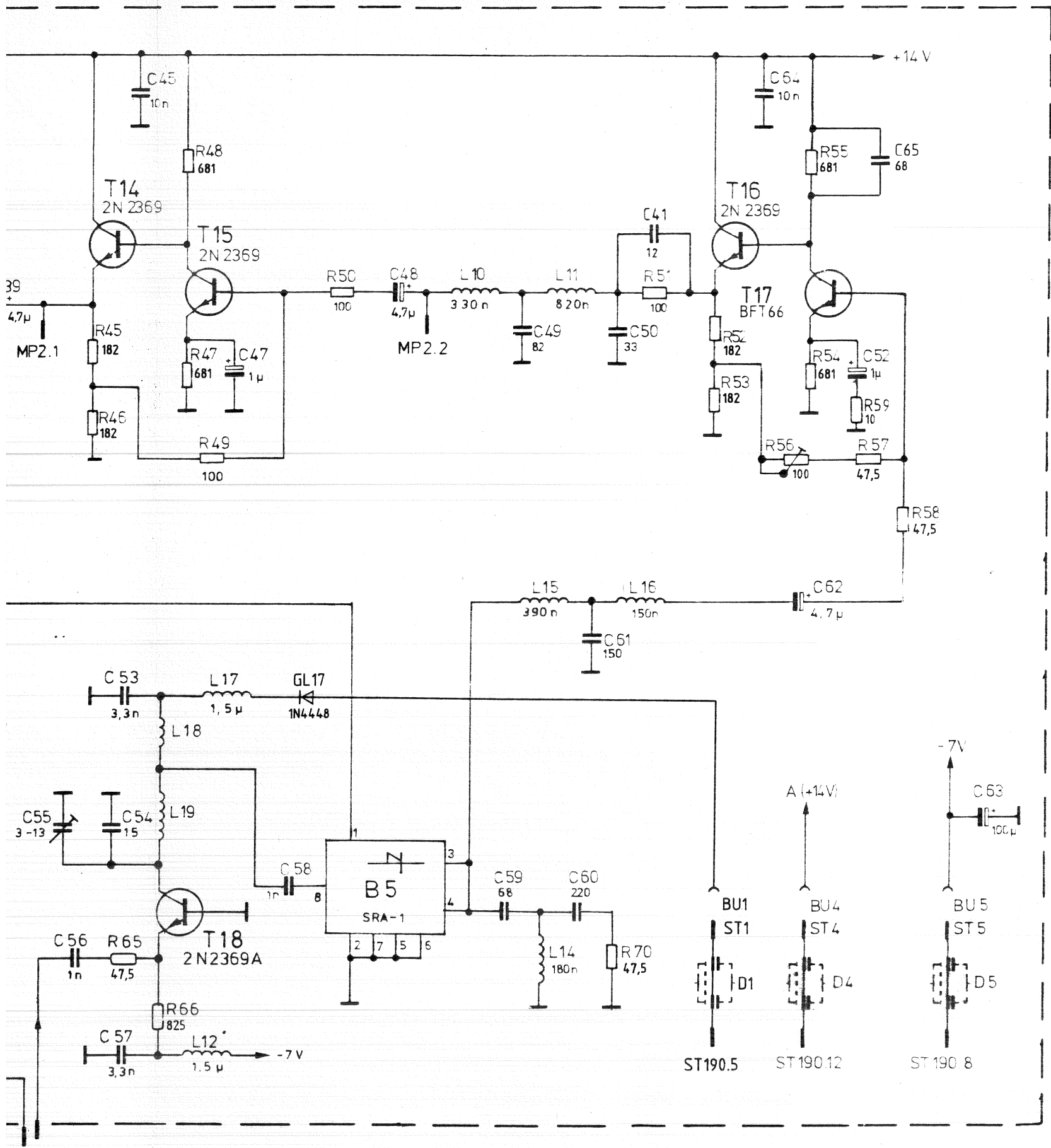

(Platte) Ausgangsteil II  
(Pcb) Output stage  
376.9324

Zuführung Ausgangsteil III  
Feed output stage  
376.9376

191  
35MHz  
om Interpol II  
om Interpol II

	<b>Stromlauf zu</b> <b>Ausgangsteil III</b> <b>Output stage III</b>	<b>Z</b>	<b>Zeichn. Nr.</b> <b>376.9318 S</b>
			376.8011 V      376.8011





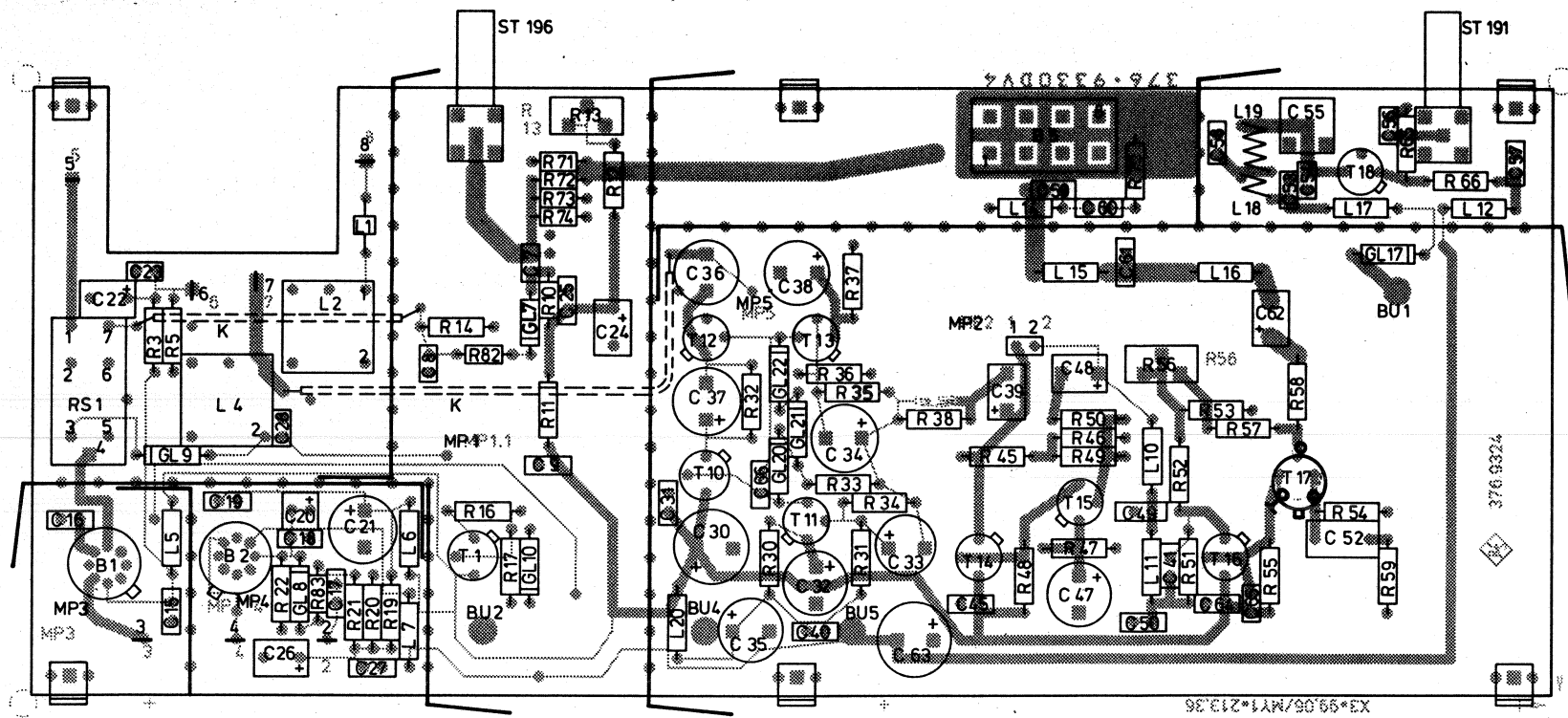

Ansicht und Leitungsführung Bauteilseite  
View of tracks on component side

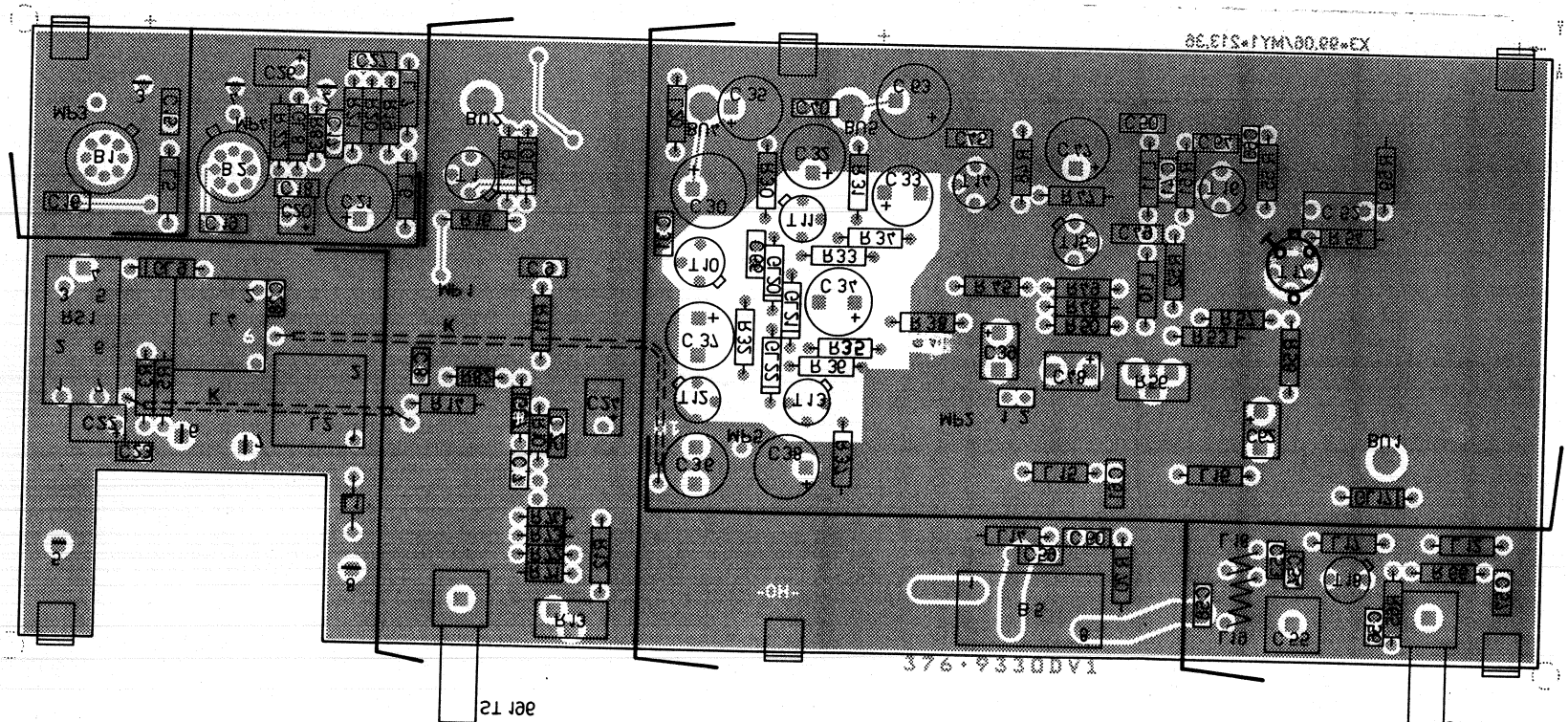

Ansicht und Leitungsführung Lotseite  
View of tracks on solder side

A	31459	02.84	BT	Maße ohne Toleranzangabe	Maßstab 1 : 1	Halbzeug, Werkstoff	Benennung	Z
B	31459	04.84	BT					
				1KGA	Tag	Name	Ausgangsteil III Output stage III	Blatt-Nr 2
				Bearb.	1.84	BT		
				Gepr.				
				Norm				
						Zeichn.-Nr	376.9324	v Bl
And Zust	Anderungs-Mitteilung	Tag	Name	zu Gerät SMPD		reg. v 376.8011V		

Für diese Unterlage behalten wir uns alle Rechte vor.

ISO Injektion Methode E

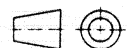







**ROHDE & SCHWARZ**

SERVICE INSTRUCTIONS

Front Panel

376.8211 (Y19)

Printed in West Germany



# Table of Contents

	Page
<u>5</u>	
<u>Service Instructions for Front Panel</u>	
<u>376.8211 (Y19)</u> .....	5.1
5.1	
Circuit Description .....	5.1
5.1.1	
Keyboard .....	5.1
5.1.2	
Rotary Knob Variation .....	5.1
5.1.3	
Indicator Elements .....	5.2
5.1.4	
Clock Fail-safe .....	5.2
5.2	
Checking and Adjusting .....	5.2
5.2.1	
Checking the Indicator Elements .....	5.2
5.2.2	
Checking and Adjusting the Tuning Sequencers .....	5.2
5.2.3	
Signature Analysis .....	5.2

Parts list  
Circuit diagram  
Component parts list

## 5.1 Circuit Description

The subassembly Y19 consists of two printed circuits:

Display/Keyboard 355.9902 and  
Control Stage 355.9860.

All controls except the rotary knobs and all indicators with their decoders and drivers are on the Display Keyboard pcb. The Control Stage handles the data traffic with the SMPC microprocessor (Y1) and provides all control signals for interrogating the keys and for the multiplexed indicators. Also on this board are the three tuning sequencers for the quasi-continuous setting and display drivers.

### 5.1.1 Keyboard

The keyboard is interrogated by B1. The control lines RS0 to RS2 are decoded by B140 (Display/Keyboard). A depressed key is detected by the signal lines RLO to RL7. B1 sets the interrupt INT 1 (K270.10) which goes L once the microprocessor has sampled the data.

### 5.1.2 Rotary Knob Variation

The tuning sequencer is a ferrite ring on the rotary knob axle which is radially magnetized alternately as north and south poles. Two staggered Hall probes scan the outer ring of the magnetic field, thus furnishing information on the angle and direction of rotation. A soft-iron link provides for locking of the knob.

The signal from one of the Hall probes (e.g. B29) produces via an inverter (B31I), two flipflops (B23) and an OR gate (B24I) at every change in polarity a signal which via B33 and B20 initiates an interrupt in the processor. B20 is operated in "Strobed Input Mode". The EXOR gate (B31II) provides for identification of the direction. Upon receiving an interrupt, the processor reads from B20 a data byte, from which it is able to recognize in which direction (DB0, DB2, DB4: H = +, L = -) which rotary knob (DB1 = level, DB3 = frequency, DB5 = modulation) has been turned, and resets the flipflops B21 to B23 by activating the line CS (B20, pin 22).

### 5.1.3 Indicator Elements

All display data is loaded by the microprocessor into the ICs B1, B20 and B50. Here, the data is stored and the signals for the multiplex operation of the seven-segment displays and the LEDs are produced.

### 5.1.4 Clock Fail-safe

B61 is a retriggerable monostable which, in the event of a clock failure (K270.7), resets B1, B20 and B50. All indicators are thereby extinguished, thus preventing any element from burning out if the multiplex clock fails.

## 5.2 Checking and Adjusting

### 5.2.1 Checking the Indicator Elements

As a check, all indicator elements light up for a few seconds after switching on the unit.

### 5.2.2 Checking the Tuning Sequencer

If an activated tuning sequencer does not or in the wrong direction vary the setting, a dual-trace oscilloscope should be connected to the two outputs of the Hall probes of the tuning sequence (e.g. B29, B30). Triggering is effected from the output which sets the flipflop (R29). When tuning the knob, two square-wave signals should become visible with TTL levels, a mark-to-space ratio of about 1:1 and a phase shift of about 90°. The edges of the trigger signals must never intersect with the edges of the direction signals in either direction of rotation. If they do intersect, one can try to adjust the Hall probes for minimum spacing from the ferrite ring and for vertical position of the probes.

### 5.2.3 Signature Analysis

The setup for the measurements and the signatures are described in the service instructions for the SMPC microprocessor (Y1, 356.1405).



ROHDE & SCHWARZ  
MÜNCHEN

Schalteillisten  
Stromläufe  
Bestückungspläne  
Parts lists  
Circuit diagrams  
Components plans

**ROHDE & SCHWARZ**

ÄZ	Datum
03	0684

Schaltteilliste für
Parts list for
<b>FRONTPLATTE</b>
<b>FRONT PANEL</b>

Sachnummer
Stock No.

376.8211.01 SA

Blatt
Page

1

Kennzeichen Component No.	Benennung/Beschreibung Designation	Sachnummer Stock No.	enthalten in contained in
BU250	FP DIREKT 48-POLIG CONNECTOR KLAR&BEIL 30R03.2111.48	FP 087.0689	300.5734
BU251	FP DIREKT 40-POLIG CONNECTOR KLAR&BEIL. NACH K-BLATT FP2021	FP 087.0672	300.5734
BU260	FP DIREKT 48-POLIG CONNECTOR KLAR&BEIL 30R03.2111.48	FP 087.0689	300.5734
BU261	FP DIREKT 40-POLIG CONNECTOR KLAR&BEIL. NACH K-BLATT FP2021	FP 087.0672	300.5734
BU510	KABEL CABLE	376.9660	
K1	HF-KABEL RF-CABLE	300.8110	
K2	HF-KABEL RF CABLE	376.9676	
K3	HF-KABEL	376.9701	
Y17	ED ANZEIGE U. TASTENFELD	355.9902.02	
Y18	ED ANSTEUERUNG	355.9860.02	

376.8211.01 SA BL 1-

Für diese Unterlage behalten wir  
uns alle Rechte vor

**ROHDE & SCHWARZ**AZ Datum  
Date  
02 1283Schaltteilliste für  
Parts list for  
ED ANZEIGE U. TASTENFELDSachnummer  
Stock No.  
355.9902.01  
SABlatt  
Page  
1

Kennzeichen Component No.	Benennung/Beschreibung Designation	Sachnummer Stock No.	enthalten in contained in
B80	BL CD4514BE 10F16 DEC DECODER RCA CD4514BE	BL 299.6589	
B81	BJ SN75492AN LED DRIV LED DRIVER TEXAS SN75492AN	BJ 257.4720	
B82	BJ SN75492AN LED DRIV LED DRIVER TEXAS SN75492AN	BJ 257.4720	
B83	BJ SN75492AN LED DRIV LED DRIVER TEXAS SN75492AN	BJ 257.4720	
B90	BL SCL4028BE BCD/DEC. DEC. IC DECODER CD4028AE SSS SCL4028BE	BL 086.7150	
B91	BJ SN75492AN LED DRIV LED DRIVER TEXAS SN75492AN	BJ 257.4720	
B92	BJ SN75492AN LED DRIV LED DRIVER TEXAS SN75492AN	BJ 257.4720	
B93	BL SN74S00N 4/2INP. NANDG. IC NAND GATE SN74S00N TEXAS SN74S00N	BL 250.3734	
B101	BP 5082-7610 7SEGM. ANZ. RT IC SEGMENT INDICATION HEWLETT HDSP4340	BP 293.6241	
BIS/TO			
B110			
B111	BP 5082-7616 +-ANZEIGE RT IC +- INDICATING 5082-761 HEWLETT HDSP4346	BP 302.7934	
B112	BP 5082-7610 7SEGM. ANZ. RT IC SEGMENT INDICATION HEWLETT HDSP4340	BP 293.6241	
BIS/TO			
B115			
B120	BP 5082-7415 7SEGM. ANZ. IC 5-DIGIT 7-SEGMENT READ HEWLETT-P 5082-7415	BP 467.3892	
B121	BP 5082-7415 7SEGM. ANZ. IC 5-DIGIT 7-SEGMENT READ HEWLETT-P 5082-7415	BP 467.3892	
B130	BP 5082-7415 7SEGM. ANZ. IC 5-DIGIT 7-SEGMENT READ HEWLETT-P 5082-7415	BP 467.3892	
B132	BP 5082-7415 7SEGM. ANZ. IC 5-DIGIT 7-SEGMENT READ HEWLETT-P 5082-7415	BP 467.3892	
B133	BP 5082-7414 4DIGIT 7SEGM IC 7SEGM. 5082-7414 HEWLETT-P. 5082-7414	BP 418.1802	
B140	BL SN74LS42N 4/10DECODER IC DECODER SN74LS42N TEXAS SN74LS42N	BL 290.8620	

355.9902 01 SA BL 1+

Kennzeichen Component No.	Benennung/Beschreibung Designation	Sachnummer Stock No.	enthalten in contained in
C80	CC 10NF-20+50%7X8R6000 CAPACITOR	CC 087.7525	
C81	VALVO 2222 63051 64051103 CC 10NF-20+50%7X8R6000 CAPACITOR	CC 087.7525	
C90	VALVO 2222 63051 64051103 CC 10NF-20+50%7X8R6000 CAPACITOR	CC 087.7525	
C91	VALVO 2222 63051 64051103 CC 10NF-20+50%7X8R6000 CAPACITOR	CC 087.7525	
C140	VALVO 2222 63051 64051103 CC 10NF-20+50%7X8R6000 CAPACITOR	CC 087.7525	
GL120	ENTHALTEN IN/INCLUDED IN S 120		
GL130	ENTHALTEN IN/INCLUDED IN S 130		
GL131	ENTHALTEN IN/INCLUDED IN S 131		
GL132	ENTHALTEN IN/INCLUDED IN S 132		
GL138	ENTHALTEN IN/INCLUDED IN S 138		
GL140	ENTHALTEN IN/INCLUDED IN S 140		
GL150	ENTHALTEN IN/INCLUDED IN S 150		
GL151	ENTHALTEN IN/INCLUDED IN S 151		
GL153	ENTHALTEN IN/INCLUDED IN S 153		
GL154	ENTHALTEN IN/INCLUDED IN S 154		
GL155	ENTHALTEN IN/INCLUDED IN S 155		
GL156	ENTHALTEN IN/INCLUDED IN S 156		
GL160	AF HLMP2300 LEDBALK.2XRT LED-ARRAY HEWLETT-P. HLMP2300	AF 300.9423	
BIS/TO GL174 GL181	AF HLMP2300 LEDBALK.2XRT LED-ARRAY HEWLETT-P. HLMP2300	AF 300.9423	
GL182	AF HLMP2300 LEDBALK.2XRT LED-ARRAY HEWLETT-P. HLMP2300	AF 300.9423	
R101	RL 0,35W15 OHM 1%TK50 RESISTOR	RL 082.9020	
R102	DRALORIC SMA0207/150HM-F-D RL 0,35W15 OHM 1%TK50 RESISTOR	RL 082.9020	





ROHDE & SCHWARZ

ÄZ Datum  
Date  
02 1283

Schalteilleiste für  
Parts list for  
ED ANZEIGE U. TASTENFELD

Sachnummer  
Stock No.  
355.9902.01 SA

Blatt  
Page  
3

Kennzeichen Component No.	Benennung/Beschreibung Designation	Sachnummer Stock No.	enthalten in contained in
R103	DRALORIC SMA0207/150HM-F-D RL 0,35W15 OHM 1%TK50 RESISTOR	RL 082.9020	
R104	DRALORIC SMA0207/150HM-F-D RL 0,35W15 OHM 1%TK50 RESISTOR	RL 082.9020	
R105	DRALORIC SMA0207/150HM-F-D RL 0,35W15 OHM 1%TK50 RESISTOR	RL 082.9020	
R106	DRALORIC SMA0207/150HM-F-D RL 0,35W15 OHM 1%TK50 RESISTOR	RL 082.9020	
R107	DRALORIC SMA0207/150HM-F-D RL 0,35W15 OHM 1%TK50 RESISTOR	RL 082.9020	
R108	DRALORIC SMA0207/150HM-F-D RL 0,35W15 OHM 1%TK50 RESISTOR	RL 082.9020	
R111	DRALORIC SMA0207/150HM-F-D RL 0,35W 33,2 OHM+-1%TK50 RESISTOR	RL 082.9359	
R112	DRALORIC SMA0207/33,2OHM-F-D RL 0,35W 33,2 OHM+-1%TK50 RESISTOR	RL 082.9359	
R113	DRALORIC SMA0207/33,2OHM-F-D RL 0,35W 33,2 OHM+-1%TK50 RESISTOR	RL 082.9359	
R114	DRALORIC SMA0207/33,2OHM-F-D RL 0,35W 33,2 OHM+-1%TK50 RESISTOR	RL 082.9359	
R115	DRALORIC SMA0207/33,2OHM-F-D RL 0,35W 33,2 OHM+-1%TK50 RESISTOR	RL 082.9359	
R116	DRALORIC SMA0207/33,2OHM-F-D RL 0,35W 33,2 OHM+-1%TK50 RESISTOR	RL 082.9359	
R117	DRALORIC SMA0207/33,2OHM-F-D RL 0,35W 33,2 OHM+-1%TK50 RESISTOR	RL 082.9359	
R118	DRALORIC SMA0207/33,2OHM-F-D RL 0,35W 33,2 OHM+-1%TK50 RESISTOR	RL 082.9359	
S100	SB SCHALTELEMENT UNBEL. SWITCH	SB 099.0672	
S101	SEL 099.0672 R&S-K-BLATT SB SCHALTELEMENT UNBEL. SWITCH	SB 099.0672	
S102	SEL 099.0672 R&S-K-BLATT SB SCHALTELEMENT UNBEL. SWITCH	SB 099.0672	
S103	SEL 099.0672 R&S-K-BLATT SB SCHALTELEMENT UNBEL. SWITCH	SB 099.0672	
S104	SEL 099.0672 R&S-K-BLATT SB SCHALTELEMENT UNBEL.	SB 099.0672	

355.9902 01 SA RL 3+

Für diese Unterlage behalten wir  
uns alle Rechte vor



ROHDE&SCHWARZ

ÄZ Datum  
Date  
02 1283

Schaltteilliste für  
Parts list for  
ED ANZEIGE U. TASTENFELD

Sachnummer  
Stock No.  
355.9902.01 SA

Blatt  
Page  
4

Kennzeichen Component No.	Benennung/Beschreibung Designation	Sachnummer Stock No.	enthalten in contained in
S105	SWITCH SEL 099.0672 R&S-K-BLATT SB SCHALTELEMENT UNBEL.	SB 099.0672	
S106	SWITCH SEL 099.0672 R&S-K-BLATT SB SCHALTELEMENT UNDEL.	SB 099.0672	
S107	SWITCH SEL 099.0672 R&S-K-BLATT SB SCHALTELEMENT UNBEL.	SB 099.0672	
S108	SWITCH SEL 099.0672 R&S-K-BLATT SB SCHALTELEMENT UNBEL.	SB 099.0672	
S109	SWITCH SEL 099.0672 R&S-K-BLATT SB SCHALTELEMENT UNBEL.	SB 099.0672	
S110	SWITCH SEL 099.0672 R&S-K-BLATT SB SCHALTELEMENT UNBEL.	SB 099.0672	
S111	SWITCH SEL 099.0672 R&S-K-BLATT SB SCHALTELEMENT UNBEL.	SB 099.0672	
S112	SWITCH SEL 099.0672 R&S-K-BLATT SB SCHALTELEMENT UNBEL.	SB 099.0672	
S113	SWITCH SEL 099.0672 R&S-K-BLATT SB SCHALTELEMENT UNBEL.	SB 099.0672	
S114	SWITCH SEL 099.0672 R&S-K-BLATT SB SCHALTELEMENT UNBEL.	SB 099.0672	
S115	SWITCH SEL 099.0672 R&S-K-BLATT SB SCHALTELEMENT UNBEL.	SB 099.0672	
S120	SWITCH SEL 099.0672 R&S-K-BLATT SB SCHALTELEMENT M.LED RT	SB 099.0689	
S121	SWITCH SEL 099.0689 R&S-K-BLATT SB SCHALTELEMENT UNBEL.	SB 099.0672	
S122	SWITCH SEL 099.0672 R&S-K-BLATT SB SCHALTELEMENT UNBEL.	SB 099.0672	
S123	SWITCH SEL 099.0672 R&S-K-BLATT SB SCHALTELEMENT UNBEL.	SB 099.0672	
S130	SWITCH SEL 099.0672 R&S-K-BLATT SB SCHALTELEMENT M.LED RT	SB 099.0689	
S131	SWITCH SEL 099.0689 R&S-K-BLATT SB SCHALTELEMENT M.LED RT	SB 099.0689	
S132	SWITCH SEL 099.0689 R&S-K-BLATT SB SCHALTELEMENT M.LED RT	SB 099.0689	
S133	SWITCH SEL 099.0689 R&S-K-BLATT SB SCHALTELEMENT UNBEL.	SB 099.0672	

355.9902 01 SA PL 4+

**ROHDE & SCHWARZ**
 ÄZ Datum  
 Date  
 02 1283

 Schalteilliste für  
 Parts list for  
 ED ANZEIGE U. TASTENFELD

 Sachnummer  
 Stock No.  
 355.9902.01 SA

 Blatt  
 Page  
 5

Kennzeichen Component No.	Benennung/Beschreibung Designation	Sachnummer Stock No.	enthalten in contained in
S134	SWITCH SEL 099.0672 R&S-K-BLATT SB SCHALTELEMENT UNBEL.	SB 099.0672	
S135	SWITCH SEL 099.0672 R&S-K-BLATT SB SCHALTELEMENT UNBEL.	SB 099.0672	
S136	SWITCH SEL 099.0672 R&S-K-BLATT SB SCHALTELEMENT UNBEL.	SB 099.0672	
S137	SWITCH SEL 099.0672 R&S-K-BLATT SB SCHALTELEMENT UNBEL.	SB 099.0672	
S138	SWITCH SEL 099.0672 R&S-K-BLATT SB SCHALTELEMENT M.LED RT	SB 099.0689	
S140	SWITCH SEL 099.0689 R&S-K-BLATT SB SCHALTELEMENT M.LED RT	SB 099.0689	
S150	SWITCH SEL 099.0689 R&S-K-BLATT SB SCHALTELEMENT M.LED RT	SB 099.0689	
S151	SWITCH SEL 099.0689 R&S-K-BLATT SB SCHALTELEMENT M.LED RT	SB 099.0689	
S152	SWITCH SEL 099.0689 R&S-K-BLATT SB SCHALTELEMENT UNBEL.	SB 099.0672	
S153	SWITCH SEL 099.0672 R&S-K-BLATT SB SCHALTELEMENT UNBEL.	SB 099.0672	
S154	SWITCH SEL 099.0672 R&S-K-BLATT SB SCHALTELEMENT M.LED RT	SB 099.0689	
S155	SWITCH SEL 099.0689 R&S-K-BLATT SB SCHALTELEMENT UNBEL.	SB 099.0672	
S156	SWITCH SEL 099.0672 R&S-K-BLATT SB SCHALTELEMENT M.LED RT	SB 099.0689	
S157	SWITCH SEL 099.0689 R&S-K-BLATT SB SCHALTELEMENT UNBEL.	SB 099.0672	
S180	SWITCH SEL 099.0672 R&S-K-BLATT SB TASTER 1POL.DOPPELKONT PUSHBUTTON SWITCH PREH 75 120-001	292.0340	
S181	SWITCH SEL 099.0672 R&S-K-BLATT SB TASTER 1POL.DOPPELKONT PUSHBUTTON SWITCH PREH 75 120-001	292.0340	
S182	SWITCH SEL 099.0672 R&S-K-BLATT SB TASTER 1POL.DOPPELKONT PUSHBUTTON SWITCH PREH 75 120-001	292.0340	
ST250	ENTHALTEN IN/INCLUDED IN LEITERPLATTE/PCB		
ST251	ENTHALTEN IN/INCLUDED IN LEITERPLATTE/PCB		

 - ENDE -  
 355.9902 01 SA BL 5-

 Für diese Unterlage behalten wir  
 uns alle Rechte vor

**ROHDE & SCHWARZ**

ÄZ	Datum
08	0686

 Schaltteilliste für  
 Parts list for  
 ED ANSTEUERUNG

Sachnummer	Stock No.
355.9860.01	SA

Blatt	Page
	1

Kennzeichen Component No.	Benennung/Beschreibung Designation	Sachnummer Stock No.	enthalten in contained in
B1	BC P8279-5 KEYB/DISP.IF I/O KEYBOARD DISPLAY INTEL P8279-5	BC 334.2496	
B2	BL CD4514BE 10F16 DEC DECODER RCA CD4514BE	BL 299.6589	
B3	BJ SN75492AN LED DRIV LED DRIVER TEXAS INST SN75492AN	BJ 257.4720	
B4	BJ SN75492AN LED DRIV LED DRIVER TEXAS INST SN75492AN	BJ 257.4720	
B5	BJ SN75492AN LED DRIV LED DRIVER TEXAS INST SN75492AN	BJ 257.4720	
B6	BJ SN75492AN LED DRIV LED DRIVER TEXAS INST SN75492AN	BJ 257.4720	
B8	BO MPQ3467 4XP TR.ARRAY TRANSISTOR ARRAY MOTOROLA MPQ3467	BO 300.6276	
B9	BO MPQ3467 4XP TR.ARRAY TRANSISTOR ARRAY MOTOROLA MPQ3467	BO 300.6276	
B10	BO MPQ3467 4XP TR.ARRAY TRANSISTOR ARRAY MOTOROLA MPQ3467	BO 300.6276	
B11	BO MPQ3467 4XP TR.ARRAY TRANSISTOR ARRAY MOTOROLA MPQ3467	BO 300.6276	
B20	BC P8279-5 KEYB/DISP.IF I/O KEYBOARD DISPLAY INTEL P8279-5	BC 334.2496	
B21	BL MM74C74N 2XD-FLIPFL. D-FLIPFLOP NSC MM74C74N	BL 347.4234	
B22	BL MM74C74N 2XD-FLIPFL. D-FLIPFLOP NSC MM74C74N	BL 347.4234	
B23	BL MM74C74N 2XD-FLIPFL. D-FLIPFLOP NSC MM74C74N	BL 347.4234	
B24	BL HEF4071BP 4X2INP. ORG OR GATE VALVO HEF4071BP	BL 347.3444	
B25	BS UGS3030U HALL-EFF.SW. HALL-EFFECT-SWITCH SPRAGUE UGS3030U	650.9342	
BIS/TO			
B30			
B31	BL HEF4077BP 4X2IN.EXNOR EX NOR GATE VALVO HEF4077BP	BL 347.3380	
B32	BL HEF4077BP 4X2IN.EXNOR EX NOR GATE VALVO HEF4077BP	BL 347.3380	

355.9860.01 SA BL 1+

Für diese Unterlage behalten wir  
uns alle Rechte vor



ROHDE & SCHWARZ

ÄZ

Datum  
Date

08

0686

Schalteilliste für  
Parts list for  
ED ANSTEUERUNG

Sachnummer  
Stock No.

355.9860.01 SA

Blatt  
Page

2

Kennzeichen Component No.	Benennung/Beschreibung Designation	Sachnummer Stock No.	enthalten in contained in
B33	BL MC14075BAL 3X3IN. ORG OR GATE RCA CD4075BF	BL 418.0164	
B34	BJ SN75492AN LED DRIV LED DRIVER TEXAS INST SN75492AN	BJ 257.4720	
B35	BJ SN75492AN LED DRIV LED DRIVER TEXAS INST SN75492AN	BJ 257.4720	
B36	BO MPQ3467 4XP TR.ARRAY TRANSISTOR ARRAY MOTOROLA MPQ3467	BO 300.6276	
B37	BO MPQ3467 4XP TR.ARRAY TRANSISTOR ARRAY MOTOROLA MPQ3467	BO 300.6276	
B50	BC P8279-5 KEYB/DISP.IF I/O KEYBOARD DISPLAY INTEL P8279-5	BC 334.2496	
B54	BJ SN75492AN LED DRIV LED DRIVER TEXAS INST SN75492AN	BJ 257.4720	
B55	BJ SN75492AN LED DRIV LED DRIVER TEXAS INST SN75492AN	BJ 257.4720	
B56	BO MPQ3467 4XP TR.ARRAY TRANSISTOR ARRAY MOTOROLA MPQ3467	BO 300.6276	
B57	BO MPQ3467 4XP TR.ARRAY TRANSISTOR ARRAY MOTOROLA MPQ3467	BO 300.6276	
B61	BL SN74LS123N 2/MONOFLOP IC MONOFLOP SN74LS85N TEXAS SN74LS123N	235.8468	
BR1	FP KURZSCHLUSSBUCHSE SHORTING PLUG PK 452-70302	FP 491.7042	
BR20	FP KURZSCHLUSSBUCHSE SHORTING PLUG PK 452-70302	FP 491.7042	
C1	CC 10NF-20+50%7X8R6000 CAPACITOR VALVO 2222 63051 64051103	CC 087.7525	
C2	CC 10NF-20+50%7X8R6000 CAPACITOR VALVO 2222 63051 64051103	CC 087.7525	
C5	CC 10NF-20+50%7X8R6000 CAPACITOR VALVO 2222 63051 64051103	CC 087.7525	
C6	CC 10NF-20+50%7X8R6000 CAPACITOR VALVO 2222 63051 64051103	CC 087.7525	
C10	CC 10NF-20+50%7X8R6000 CAPACITOR VALVO 2222 63051 64051103	CC 087.7525	

355.9860.01 SA BL 2+

Kennzeichen Component No.	Benennung/Beschreibung Designation	Sachnummer Stock No.	enthalten in contained in
C11	CC 10NF-20+50%7X8R6000 CAPACITOR VALVO 2222 63051 64051103	CC 087.7525	
C20	CC 10NF-20+50%7X8R6000 CAPACITOR VALVO 2222 63051 64051103	CC 087.7525	
C21	CC 10NF-20+50%7X8R6000 CAPACITOR VALVO 2222 63051 64051103	CC 087.7525	
C22	CC 10NF-20+50%7X8R6000 CAPACITOR VALVO 2222 63051 64051103	CC 087.7525	
C23	CC 10NF-20+50%7X8R6000 CAPACITOR VALVO 2222 63051 64051103	CC 087.7525	
C24	CE 1000UF6V RD15X36 ELECTROLYTIC CAPACITOR ROEDERST. EB00GD410B	CE 022.7108	
C25	CE 1000UF6V RD15X36 ELECTROLYTIC CAPACITOR ROEDERST. EB00GD410B	CE 022.7108	
C26	CE 1000UF6V RD15X36 ELECTROLYTIC CAPACITOR ROEDERST. EB00GD410B	CE 022.7108	
C40	CC 10NF-20+50%7X8R6000 CAPACITOR VALVO 2222 63051 64051103	CC 087.7525	
C41	CC 10NF-20+50%7X8R6000 CAPACITOR VALVO 2222 63051 64051103	CC 087.7525	
C50	CC 10NF-20+50%7X8R6000 CAPACITOR VALVO 2222 63051 64051103	CC 087.7525	
C70	CC 330PF+-10%3X4R2000 CAPACITOR VALVO 2222 63051 331	CC 087.6970	
K270	DX FLACHBANDKABEL RIBBON CABLE	300.8056	
K271	DX FLACHBANDKABEL RIBBON CABLE	300.8062	
L1	LD 400UH 1,6A RD23X12 CHOKE VAC ZKB 610/083-XX-H2	356.0709	
R1	RL 0,35W22,10 OHM+-1%TK50 RESISTOR DRALORIC SMA0207/22,10HM-F-D	RL 082.9188	
R2	RL 0,35W22,10 OHM+-1%TK50 RESISTOR DRALORIC SMA0207/22,10HM-F-D	RL 082.9188	
R3	RL 0,35W22,10 OHM+-1%TK50 RESISTOR DRALORIC SMA0207/22,10HM-F-D	RL 082.9188	

 Für diese Unterlage behalten wir  
 uns alle Rechte vor



ROHDE & SCHWARZ

ÄZ Datum  
Date  
08 0686

Schaltteilliste für  
Parts list for  
ED ANSTEUERUNG

Sachnummer  
Stock No.  
355.9860.01 SA

Blatt  
Page  
4

Kennzeichen Component No.	Benennung/Beschreibung Designation	Sachnummer Stock No.	enthalten in contained in
R4	RL 0,35W22,10 OHM+-1%TK50 RESISTOR DRALORIC SMA0207/22,10HM-F-D	RL 082.9188	
R5	RL 0,35W22,10 OHM+-1%TK50 RESISTOR DRALORIC SMA0207/22,10HM-F-D	RL 082.9188	
R6	RL 0,35W22,10 OHM+-1%TK50 RESISTOR DRALORIC SMA0207/22,10HM-F-D	RL 082.9188	
R7	RL 0,35W22,10 OHM+-1%TK50 RESISTOR DRALORIC SMA0207/22,10HM-F-D	RL 082.9188	
R8	RL 0,35W22,10 OHM+-1%TK50 RESISTOR DRALORIC SMA0207/22,10HM-F-D	RL 082.9188	
R10	RN 4X120 OHM+-2%SIL 8 H5 RESISTOR NETWORK BECKMAN 764-3-R1200HM	RN 291.4470	
R11	RN 4X120 OHM+-2%SIL 8 H5 RESISTOR NETWORK BECKMAN 764-3-R1200HM	RN 291.4470	
R12	RN 4X120 OHM+-2%SIL 8 H5 RESISTOR NETWORK BECKMAN 764-3-R1200HM	RN 291.4470	
R13	RN 4X120 OHM+-2%SIL 8 H5 RESISTOR NETWORK BECKMAN 764-3-R1200HM	RN 291.4470	
R15	RN 4X1,0KOHM+-2%SIL 8 H5 RESISTOR NETWORK BECKMAN 764-3-R 1KOHM	RN 291.4370	
R16	RN 4X1,0KOHM+-2%SIL 8 H5 RESISTOR NETWORK BECKMAN 764-3-R 1KOHM	RN 291.4370	
R17	RN 4X1,0KOHM+-2%SIL 8 H5 RESISTOR NETWORK BECKMAN 764-3-R 1KOHM	RN 291.4370	
R18	RN 4X1,0KOHM+-2%SIL 8 H5 RESISTOR NETWORK BECKMAN 764-3-R 1KOHM	RN 291.4370	
R24	RL 0,35W 4,75KOHM+-1%TK50 RESISTOR DRALORIC SMA0207/4,75K-F-D	RL 083.1097	
R25	RL 0,35W 4,75KOHM+-1%TK50 RESISTOR DRALORIC SMA0207/4,75K-F-D	RL 083.1097	
R26	RL 0,35W 4,75KOHM+-1%TK50 RESISTOR DRALORIC SMA0207/4,75K-F-D	RL 083.1097	
R27	RL 0,35W 4,75KOHM+-1%TK50 RESISTOR DRALORIC SMA0207/4,75K-F-D	RL 083.1097	
R28	RL 0,35W 4,75KOHM+-1%TK50 RESISTOR DRALORIC SMA0207/4,75K-F-D	RL 083.1097	
R29	RL 0,35W 4,75KOHM+-1%TK50 RESISTOR DRALORIC SMA0207/4,75K-F-D	RL 083.1097	

355.9860.01 SA BL 4+



**ROHDE & SCHWARZ**

ÄZ	Datum Date
08	0686

 Schaltteilliste für  
 Parts list for  
**ED ANSTEUERUNG**

Sachnummer Stock No.
355.9860.01 SA

Blatt Page
5

Kennzeichen Component No.	Benennung/Beschreibung Designation	Sachnummer Stock No.	enthalten in contained in
R30	RL 0,35W 4,75KOHM+-1%TK50 RESISTOR DRALORIC SMA0207/4,75K-F-D	RL 083.1097	
R40	RN 4X120 OHM+-2%SIL 8 H5 RESISTOR NETWORK BECKMAN 764-3-R1200HM	RN 291.4470	
R41	RN 4X120 OHM+-2%SIL 8 H5 RESISTOR NETWORK BECKMAN 764-3-R1200HM	RN 291.4470	
R45	RN 4X1,0KOHM+-2%SIL 8 H5 RESISTOR NETWORK BECKMAN 764-3-R 1KOHM	RN 291.4370	
R46	RN 4X1,0KOHM+-2%SIL 8 H5 RESISTOR NETWORK BECKMAN 764-3-R 1KOHM	RN 291.4370	
R50	RN 4X120 OHM+-2%SIL 8 H5 RESISTOR NETWORK BECKMAN 764-3-R1200HM	RN 291.4470	
R51	RN 4X120 OHM+-2%SIL 8 H5 RESISTOR NETWORK BECKMAN 764-3-R1200HM	RN 291.4470	
R55	RN 4X1,0KOHM+-2%SIL 8 H5 RESISTOR NETWORK BECKMAN 764-3-R 1KOHM	RN 291.4370	
R56	RN 4X1,0KOHM+-2%SIL 8 H5 RESISTOR NETWORK BECKMAN 764-3-R 1KOHM	RN 291.4370	
R60	RL 0,35W 33,2 OHM+-1%TK50 RESISTOR DRALORIC SMA0207/33,2OHM-F-D	RL 082.9359	
R61	RL 0,35W 33,2 OHM+-1%TK50 RESISTOR DRALORIC SMA0207/33,2OHM-F-D	RL 082.9359	
R62	RL 0,35W 33,2 OHM+-1%TK50 RESISTOR DRALORIC SMA0207/33,2OHM-F-D	RL 082.9359	
R63	RL 0,35W 33,2 OHM+-1%TK50 RESISTOR DRALORIC SMA0207/33,2OHM-F-D	RL 082.9359	
R64	RL 0,35W 33,2 OHM+-1%TK50 RESISTOR DRALORIC SMA0207/33,2OHM-F-D	RL 082.9359	
R65	RL 0,35W 33,2 OHM+-1%TK50 RESISTOR DRALORIC SMA0207/33,2OHM-F-D	RL 082.9359	
R66	RL 0,35W 33,2 OHM+-1%TK50 RESISTOR DRALORIC SMA0207/33,2OHM-F-D	RL 082.9359	
R67	RL 0,35W 33,2 OHM+-1%TK50 RESISTOR DRALORIC SMA0207/33,2OHM-F-D	RL 082.9359	
R70	RL 0,35W 82,5KOHM+-1%TK50 RESISTOR DRALORIC SMA0207/82,5K-F-C	RL 082.2302	
ST1	FP INDIREKT.STECKERL.36P. PIN CONNECTOR BERG 75160-102-36	FP 242.3600	

355.9860.01 SA BL 5+

Für diese Unterlage behalten wir uns alle Rechte vor



ROHDE & SCHWARZ

ÄZ

Datum  
Date

08

0686

Schaltteilliste für  
Parts list for  
ED ANSTEUERUNG

Sachnummer  
Stock No.

355.9860.01

SA

Blatt  
Page

6

Kennzeichen Component No.	Benennung/Beschreibung Designation	Sachnummer Stock No.	enthalten in contained in
ST20	FP INDIREKT. STECKERL. 36P. PIN CONNECTOR	FP 242.3600	
ST260	BERG 75160-102-36 ENTHALTEN IN/INCLUDED IN		
ST261	LEITERPLATTE/PCB ENTHALTEN IN/INCLUDED IN		
	LEITERPLATTE/PCB		
			- ENDE -

355.9860.01 SA BL 6-

From

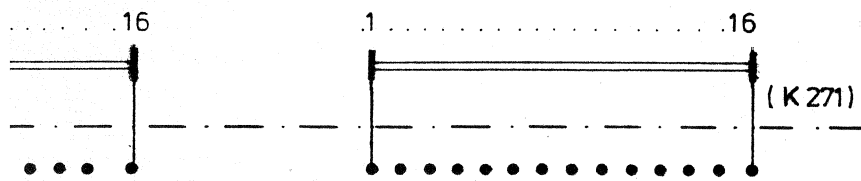

(ST 261)

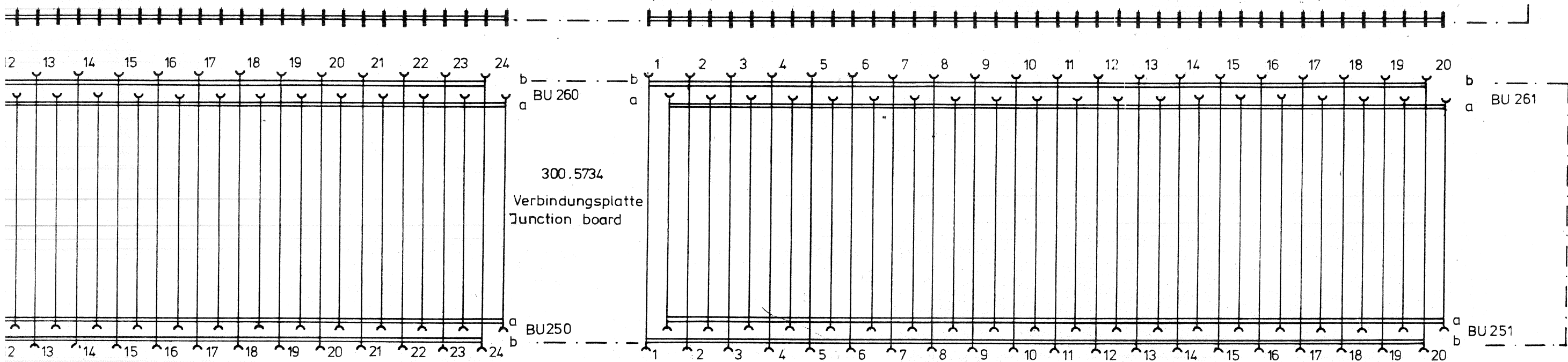

(ST 251)

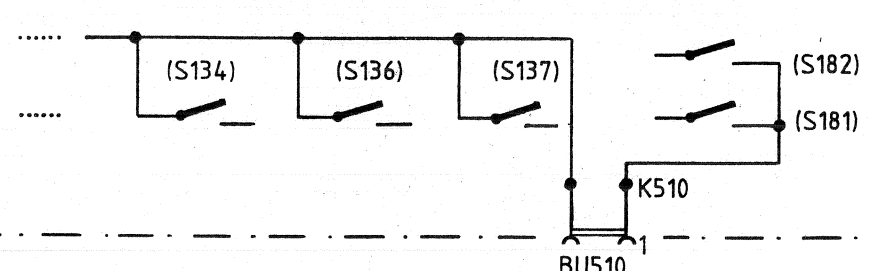

Zur Option/To option  
SMPD-B1  
377.0914

um Motherboard  
o Motherboard  
s. 300.1000 S)

	Stromlauf zu Frontplatte	Front panel	
			Zeichn. Nr. 376.8211 S
		376.8011 V	376.8011



Display

NF  
AF  
(kHz)

FM  
PM

AM  
%

B 121

hp 5082 - 7415

B 130

hp 5082 - 7415

B132

hp 5082 - 7415

B133

hp 5082-7414

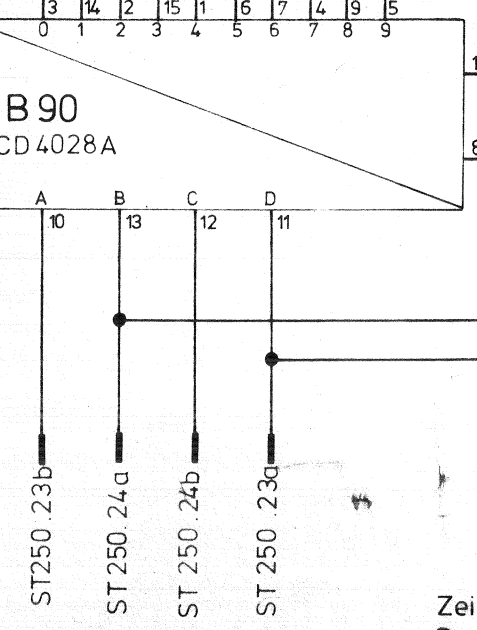
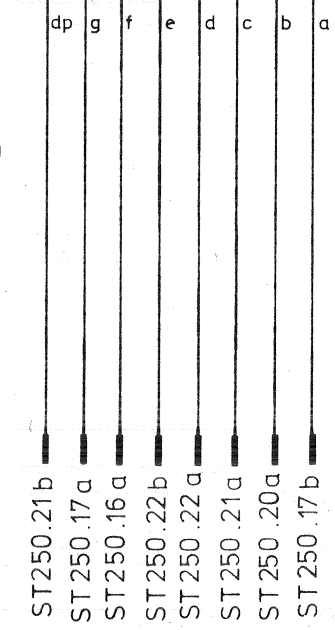
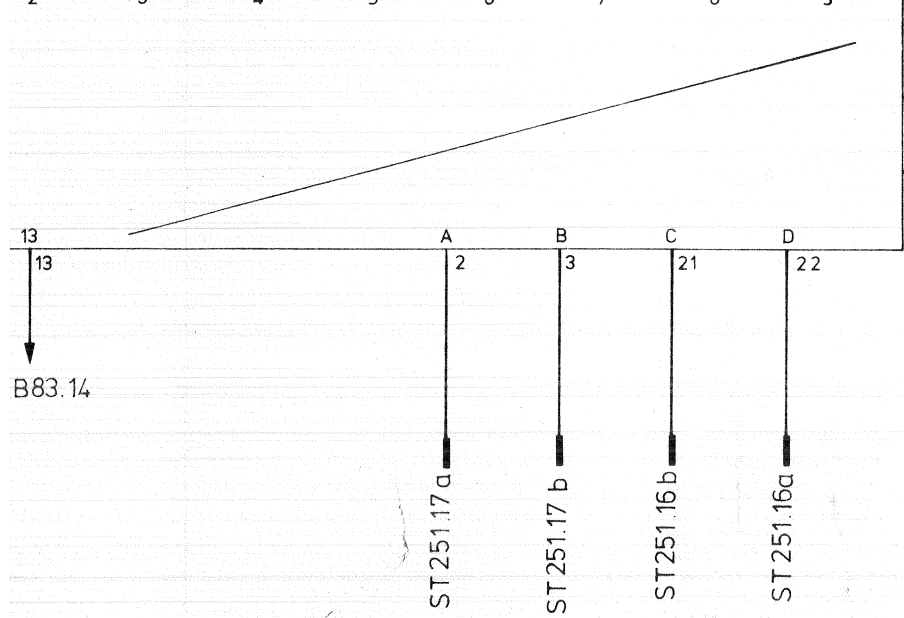
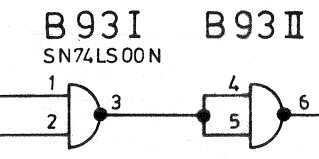
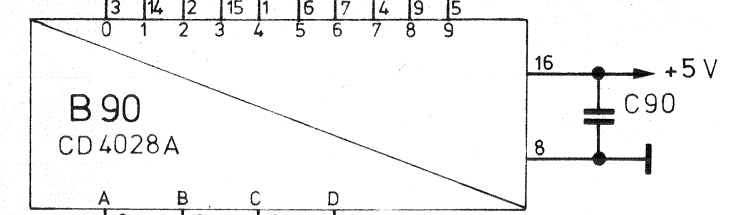
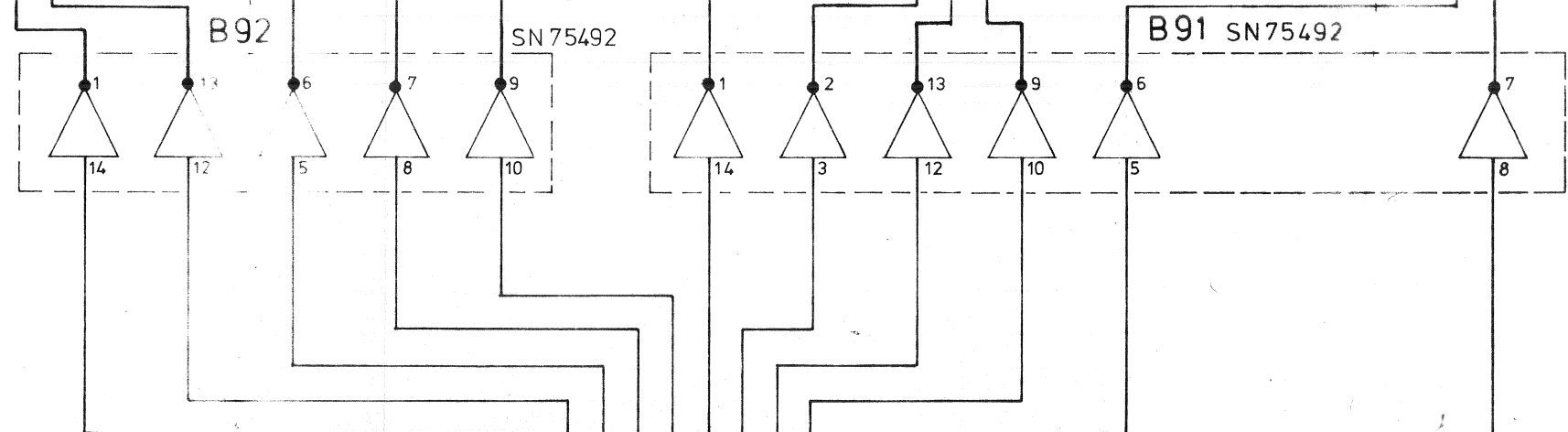
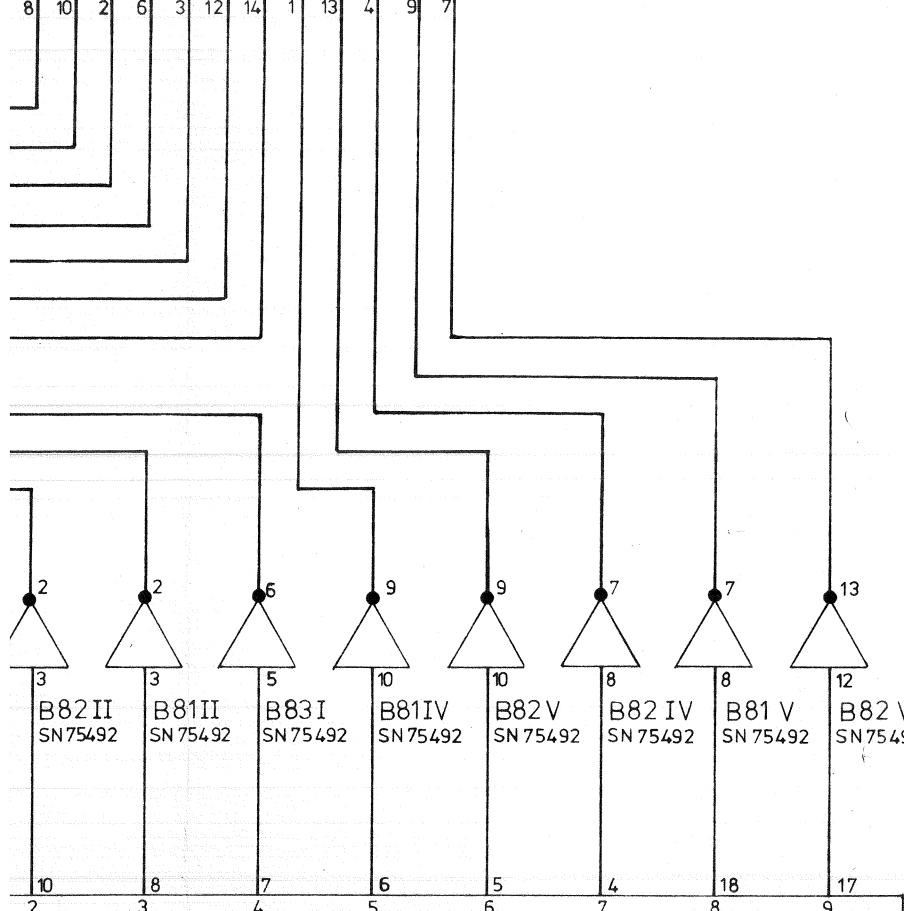
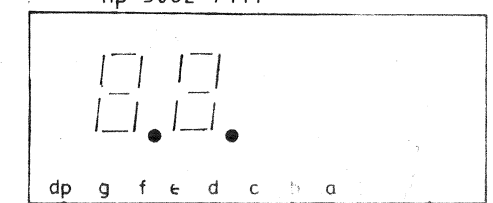
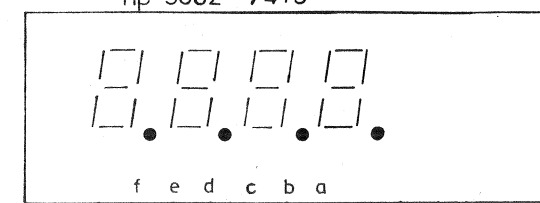
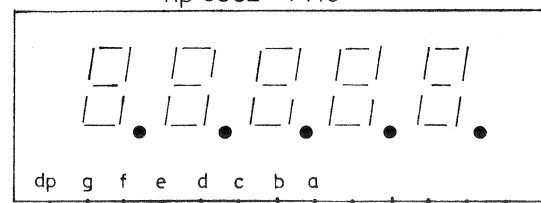
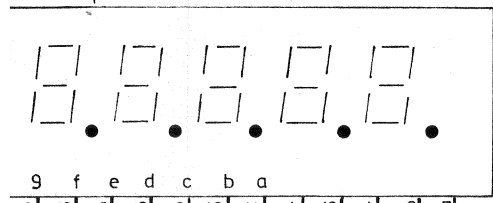

Zeichnung besteht aus 2 Blatt  
Drawing consisting of 2 sheets

zur Ansteuerung  
to Drive stage

Z	Stromlauf zu Anzeig und Tastenfeld Indication and keyboard		Zeichn. Nr. 355.9902 S	Blatt Nr. 1
			300 1000 V	300.1068



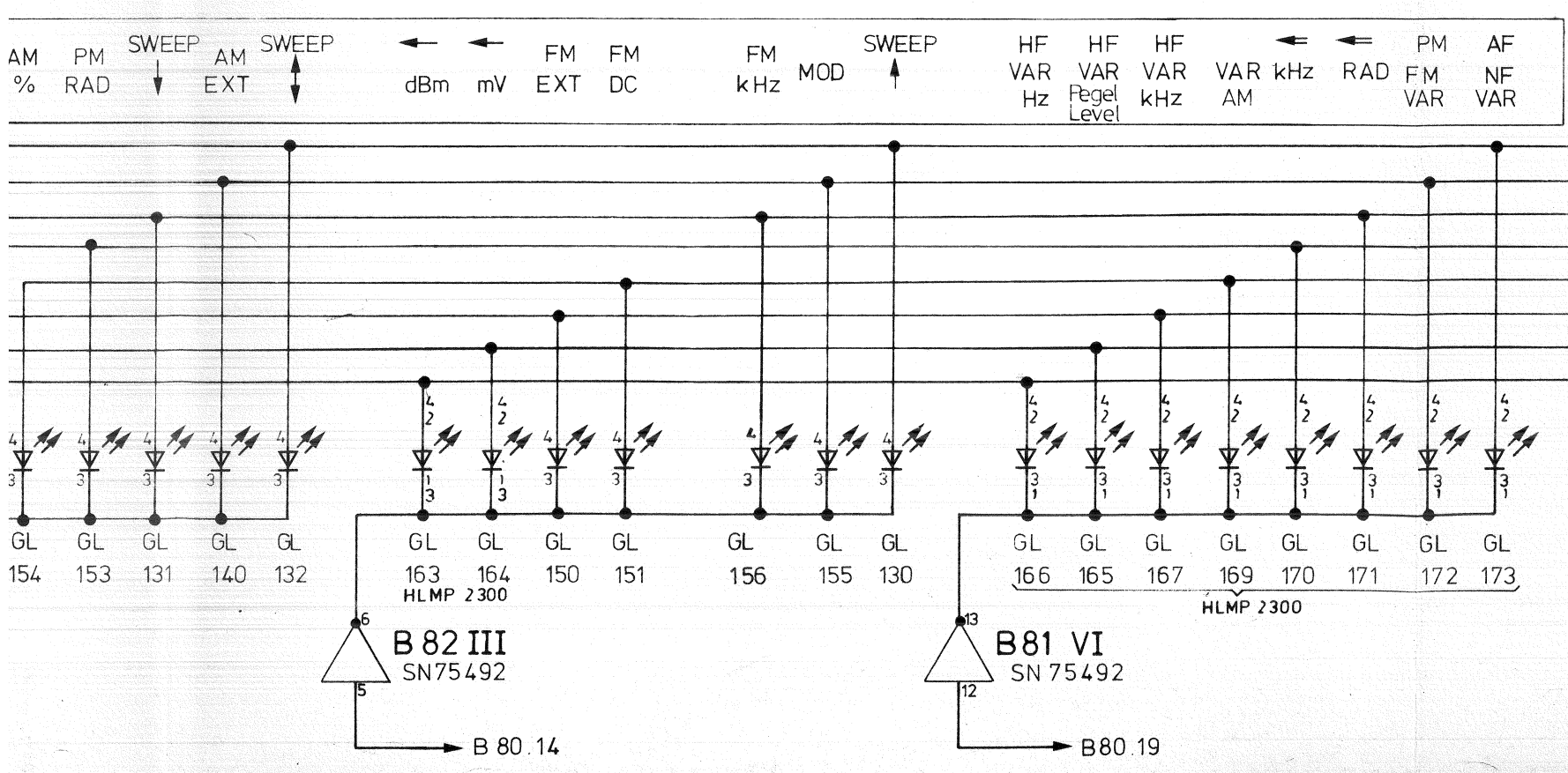
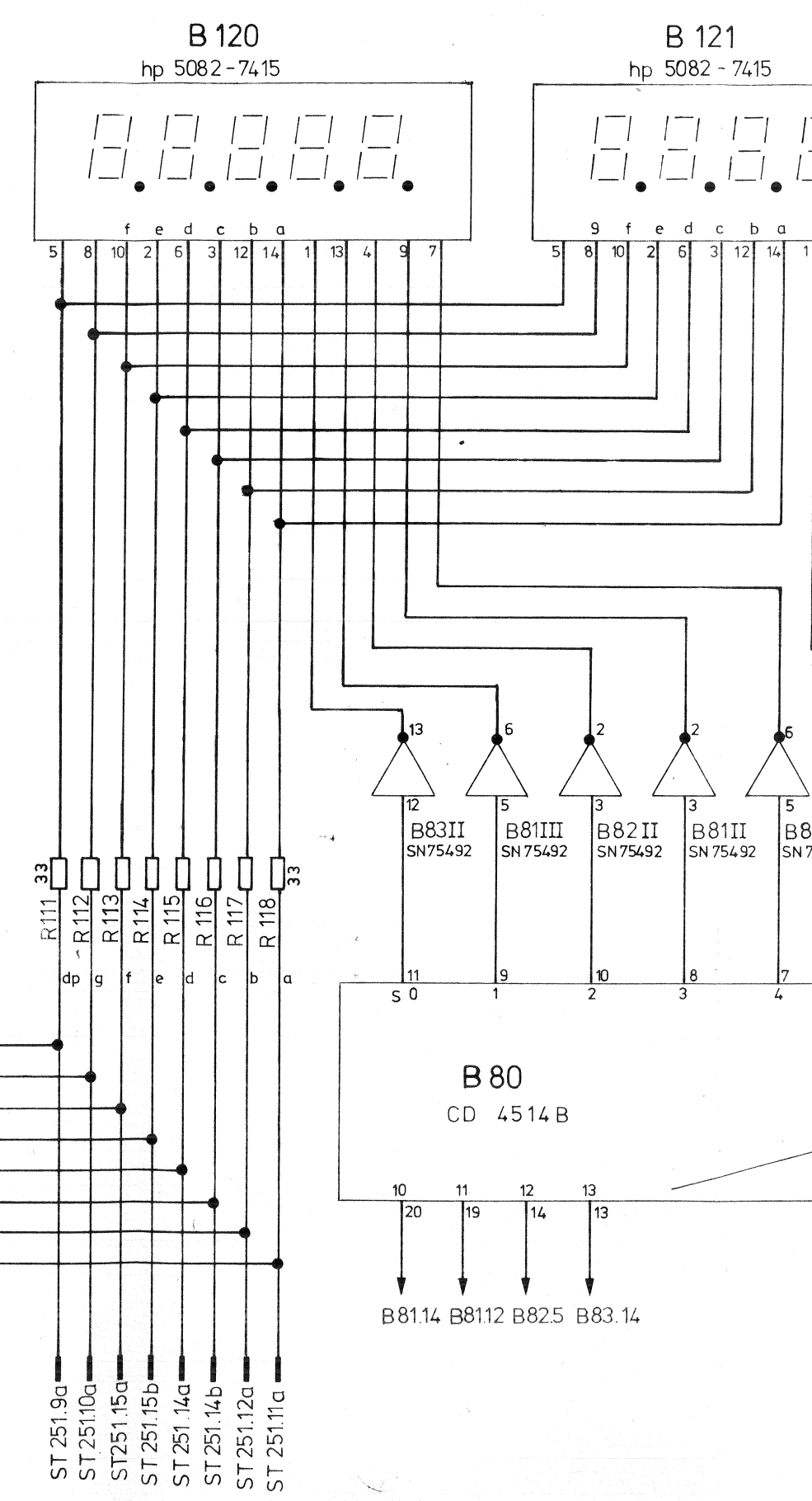
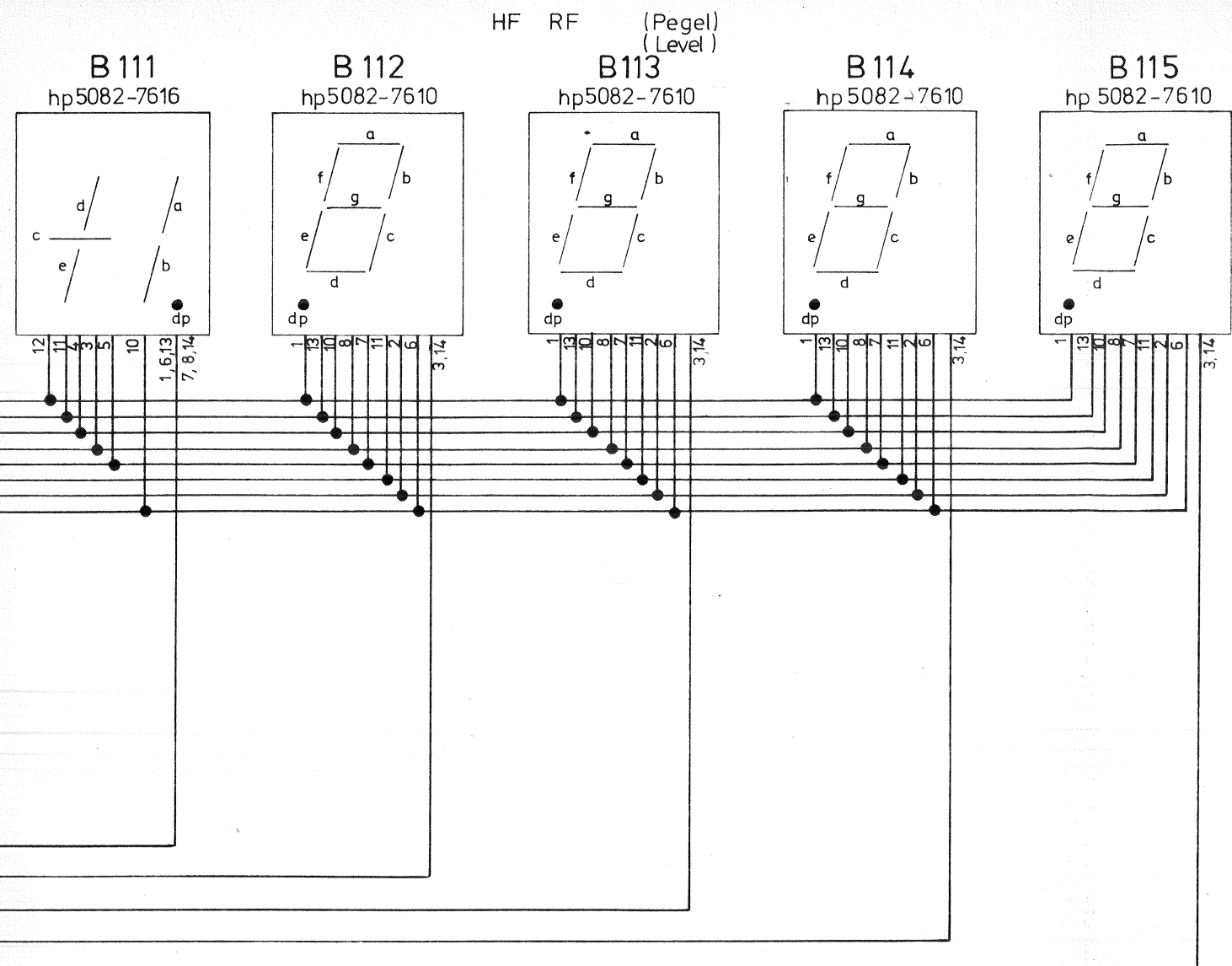

Display

RF HF (MHz)

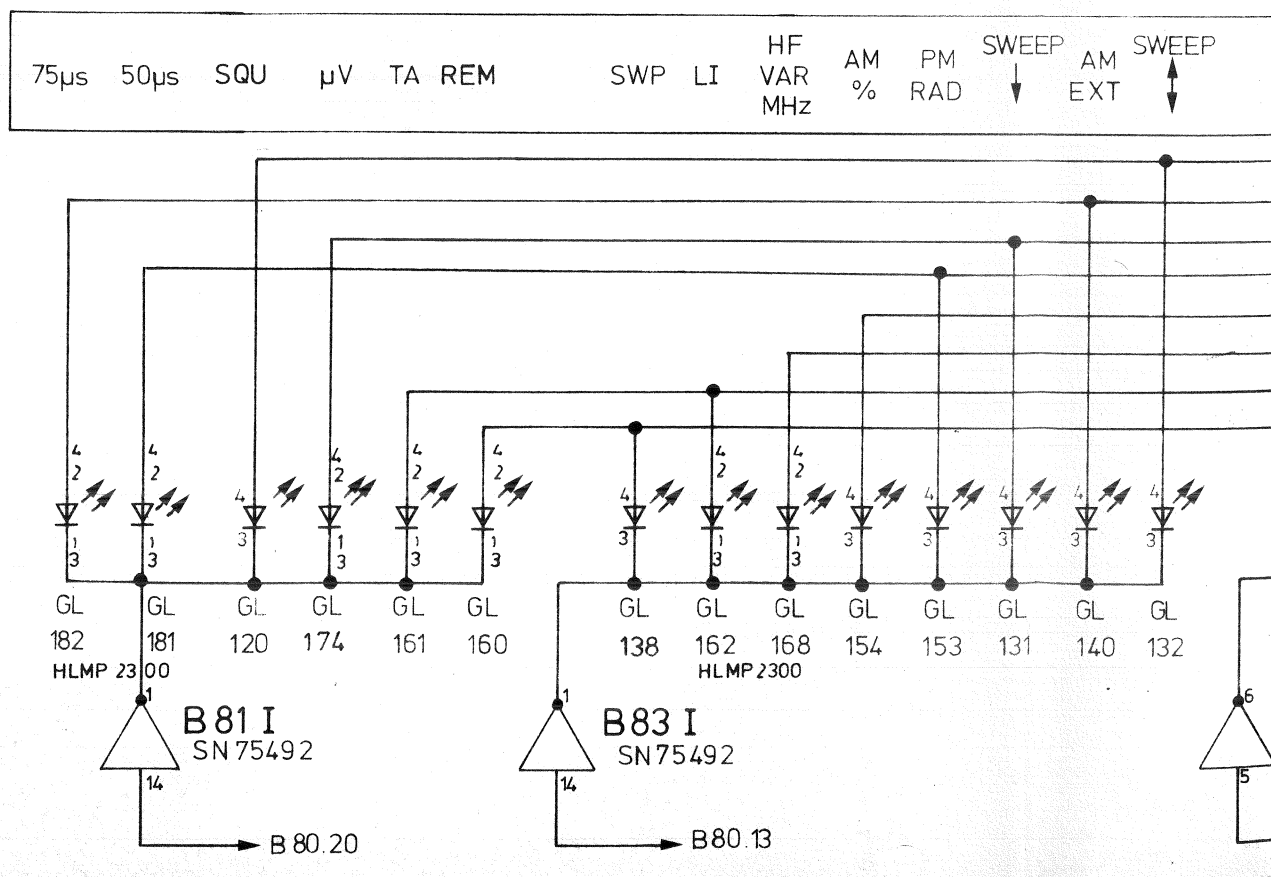
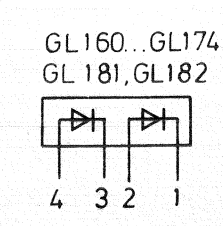
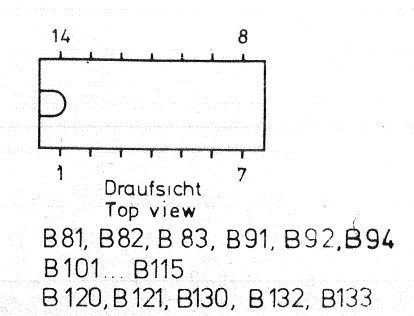
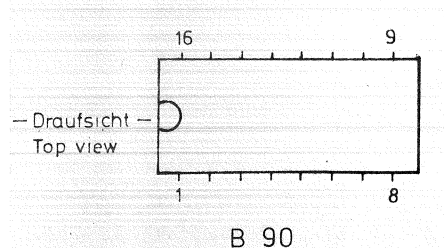
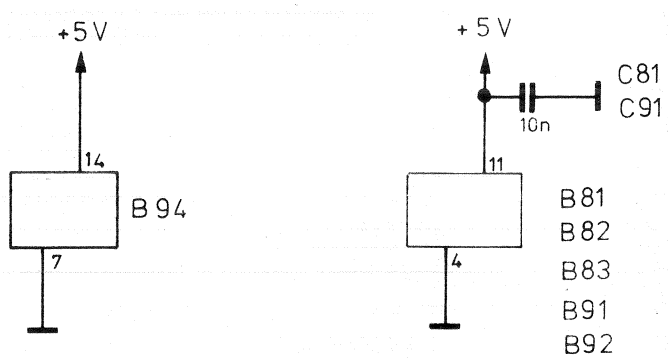
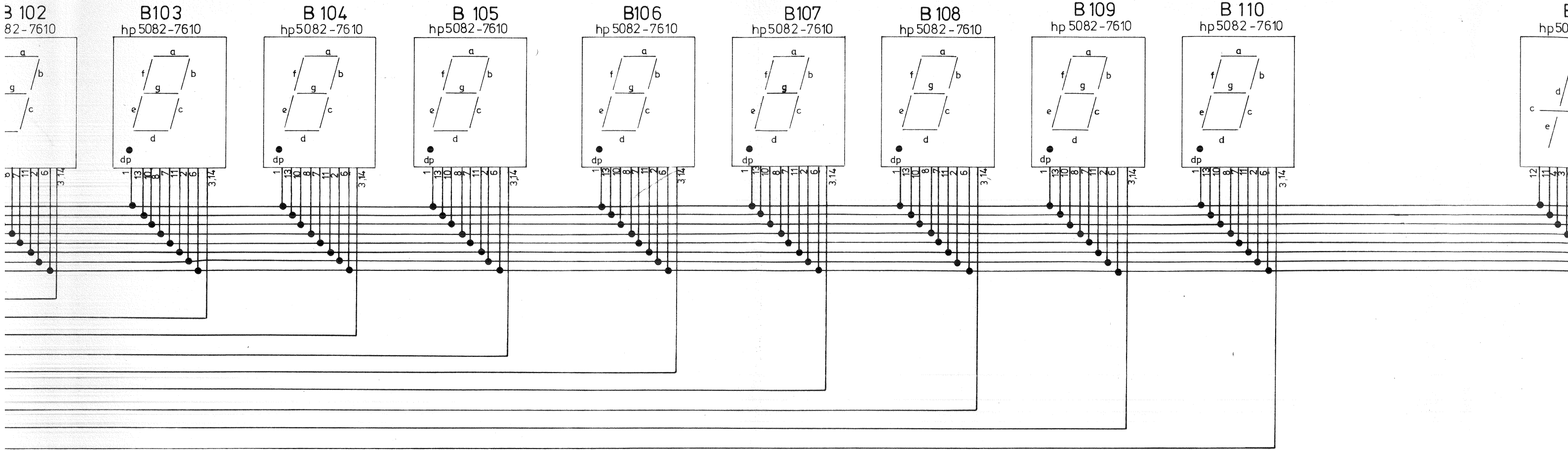



And. Mittg. Nr.	
And. zuef.	
Name	
Datum	
And. Mittg. Nr.	
And. zuef.	

Diese Zeichnung ist unser Eigentum. Vervielfältigung, unbefugte Verwertung, Mitteilung an andere ist strafbar und schadenersatzpflichtig.

**ROHDE & SCHWARZ · MÜNCHEN**

IKGA	geschnitten	geprüft	normgepr.
Name	gu	ib	
Datum	8.8	8.83	
And. Mittg. Nr.	A 31057		
Datum	12.83		
Name	GS		

zur Ansteuerung  
to Drive stage

- ST 250 .b16
- ST 250 .a15
- ST 250 .a8
- ST 250 .a5
- ST 250 .b6
- ST 250 .b9
- ST 250 .a9
- ST 250 .b8
- ST 250 .a4
- ST 250 .b5
- ST 250 .b4
- ST 250 .b3
- ST 250 .a2
- ST 250 .a3
- ST 250 .a1
- ST 250 .b2
- ST 250 .b1
- ST 251 .a20
- ST 251 .b20
- ST 251 .a19
- ST 251 .b19
- ST 251 .a18
- ST 251 .b18

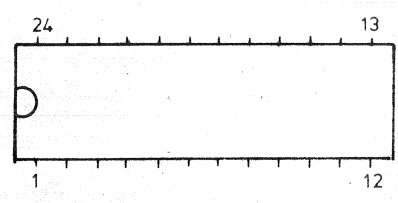
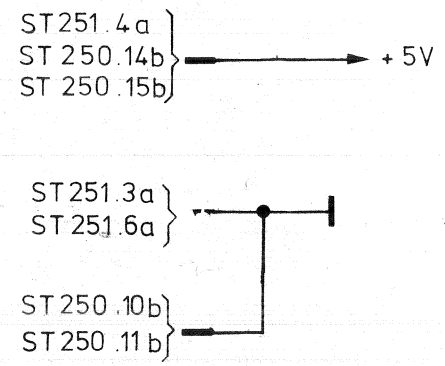
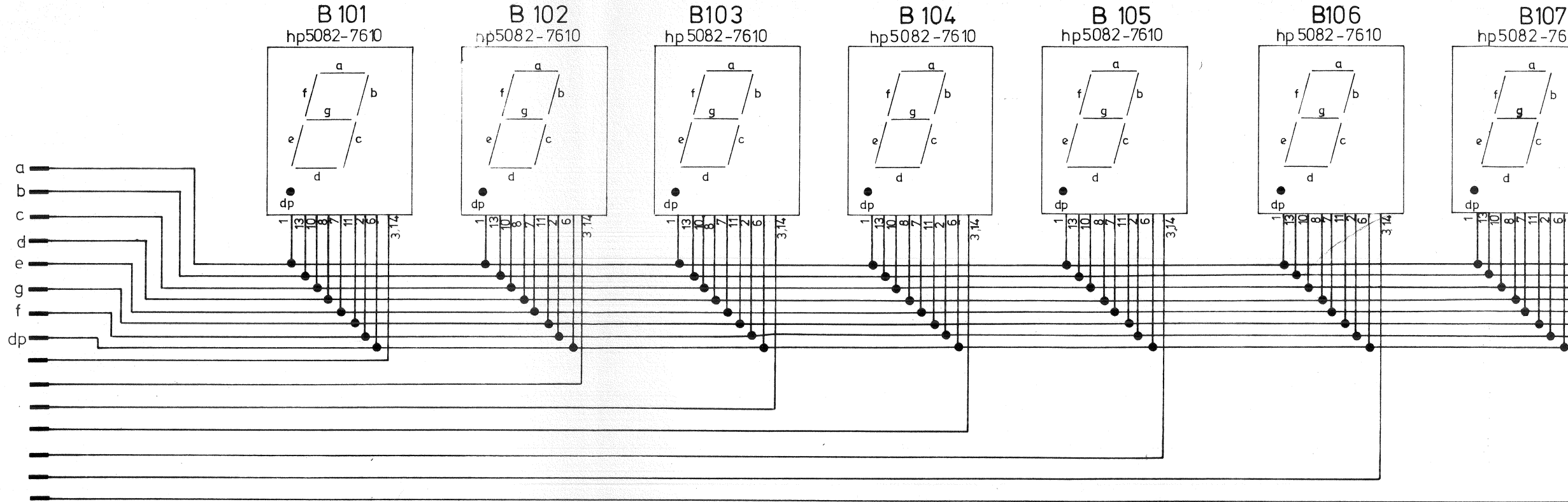

B 80

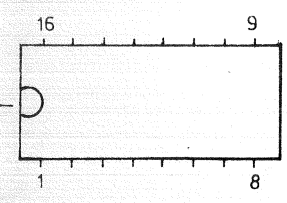

B 90

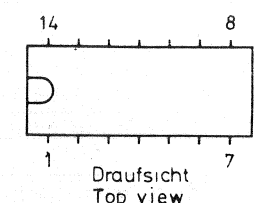

B 81, B 82, B 83, B 91, B 92, B 94  
B 101... B 115  
B 120, B 121, B 130, B 132, B 133

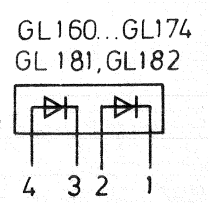
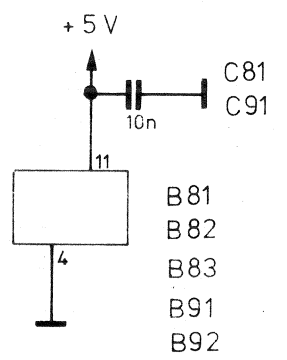

RF HF (MHz)

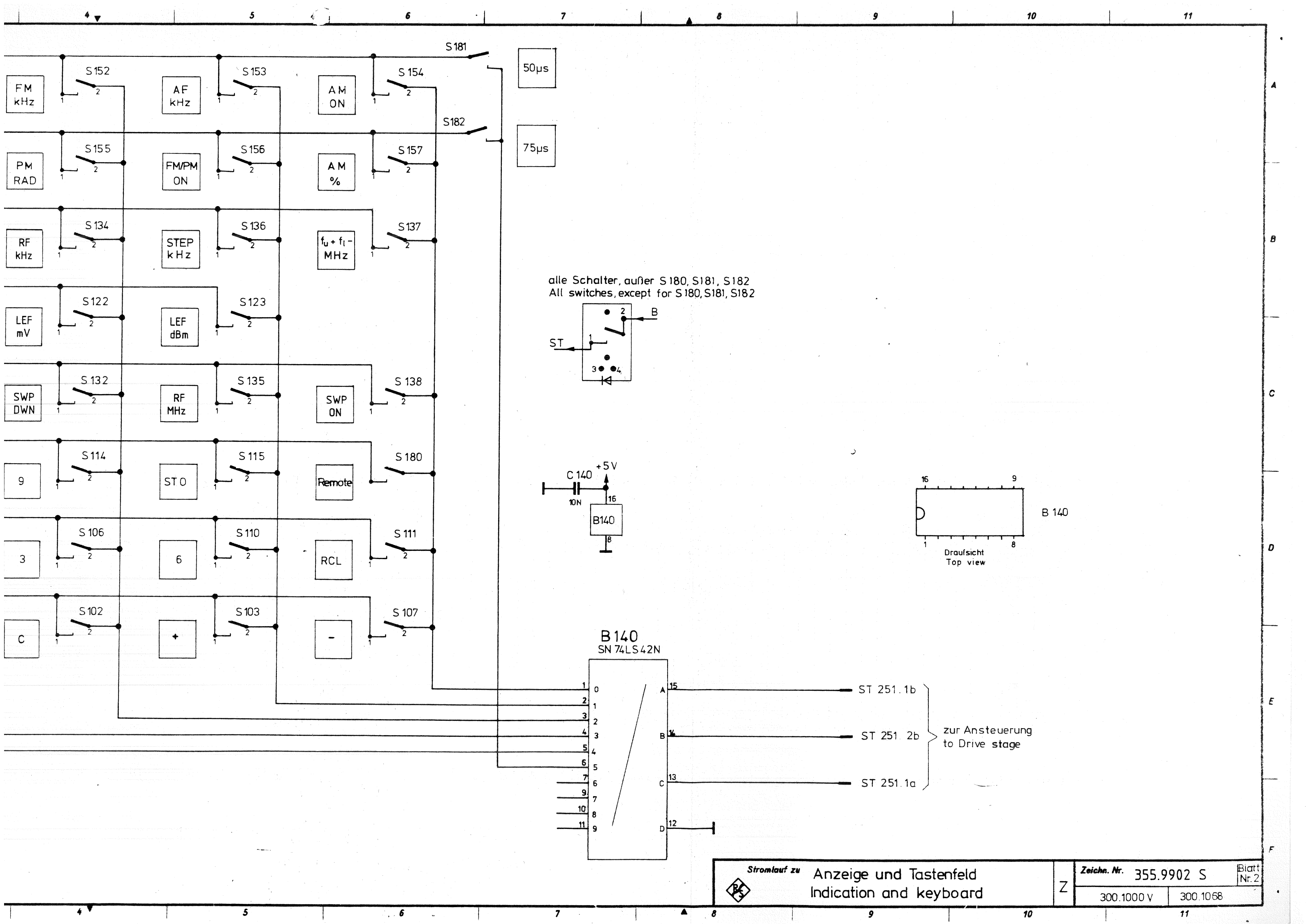

50µs

75µs

alle Schalter, außer S180, S181, S182  
 All switches, except for S180, S181, S182

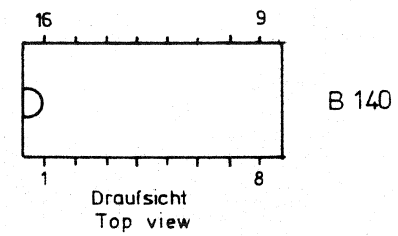
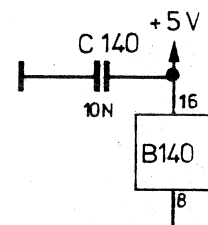
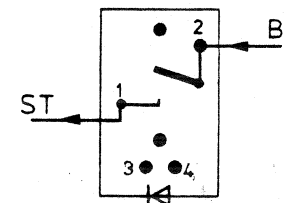

B140  
 SN 74LS42N

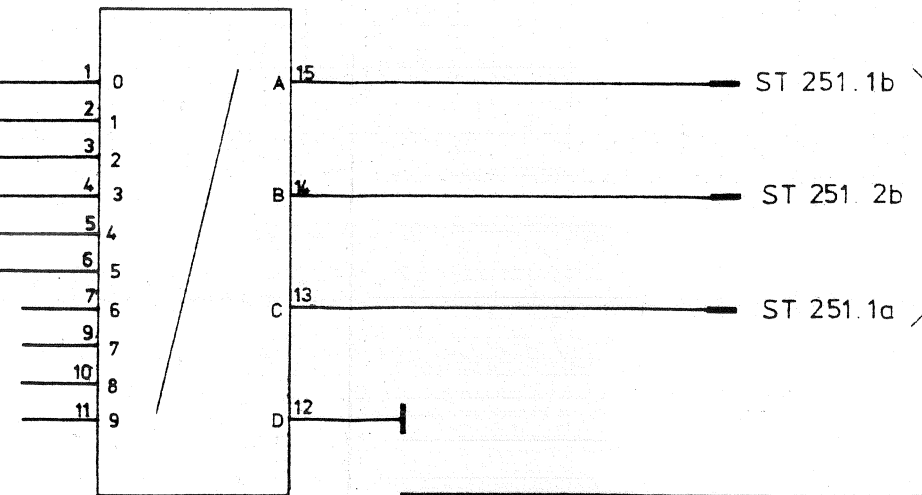

zur Ansteuerung  
 to Drive stage

Name	
Datum	
and. / Fertigung Nr.	
Maßstab	
Legende	
Nr.	
Zeichn.	

Diese Zeichnung ist unser Eigentum. Vervielfältigung, Verbreitung, Verwertung, Mitteilung an andere ist strafbar und Schadensersatzpflichtig.

**ROHDE & SCHWARZ · MÜNCHEN**

INQUA	
gezeichnet	8.83
bearbeitet	ib
geprüft	
normgepr.	

zur Ansteuerung  
to Drive stage

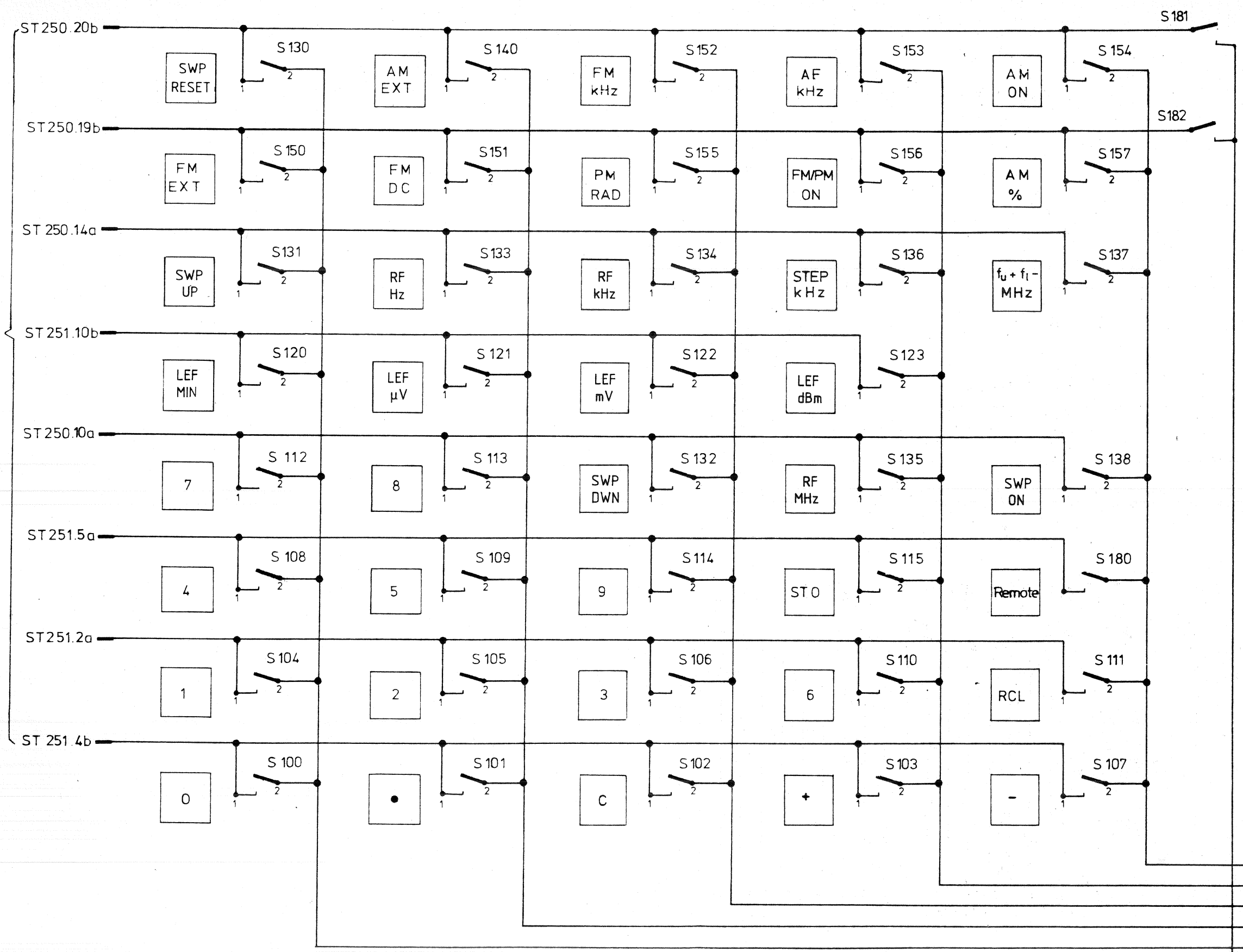

50μs  
75μs

alle Schalter, außer S 180, S 181, S 182  
All switches, except for S 180, S 181, S 182

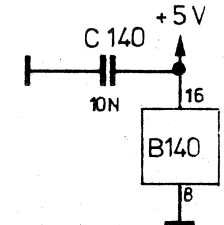
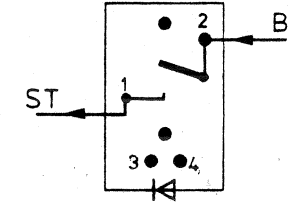

**B 140**  
SN 74LS42N

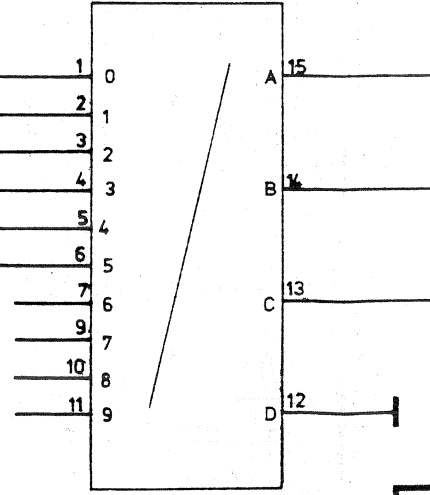

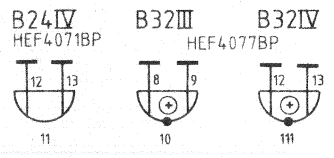

5V

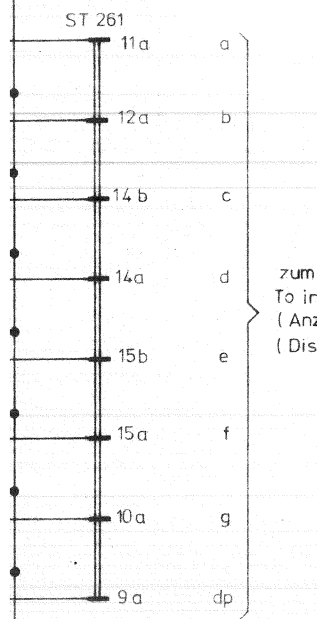

zum Anzeige- und Tastenfeld  
To indication and keyboard  
(Anzeigen und Leuchtdioden)  
(Display and LED)

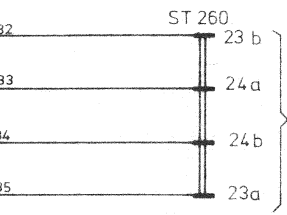
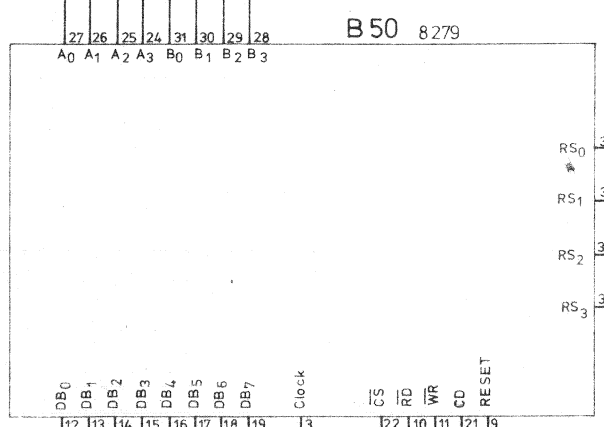
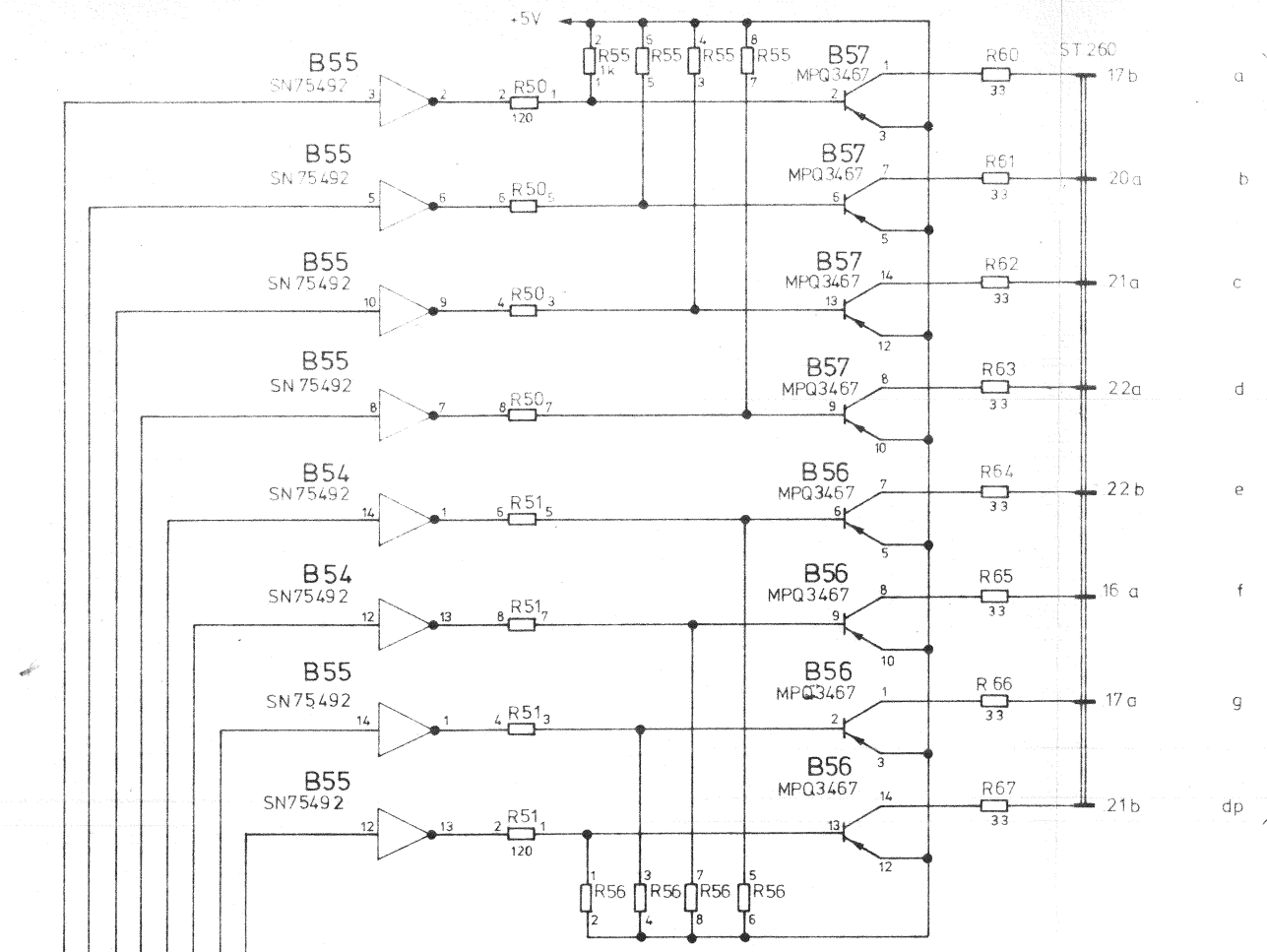

zum Anzeige- und Tastenfeld  
To indication and keyboard  
(zum Decoder für NF und FM / M und AM)  
(To decoder for AF and FM / M and AM)

K 271  
CS III vom Rechner  
From computer

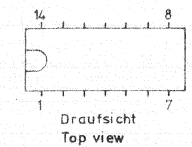

B3, B4, B5, B6, B8, B9, B10,  
B11, B25, B26, B27, B28, B29,  
B30, B31, B32, B33, B34, B35,  
B36, B37, B54, B55, B56, B57  
B21, B22, B23, B24, B31, B32, B33

zum Anzeige- und Tastenfeld  
To indication and keyboard  
(für NF, FM / M, AM)  
(For AF, FM / M, AM)

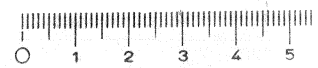
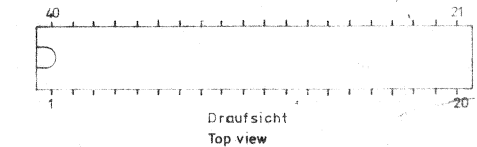
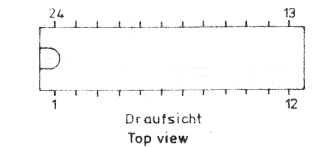
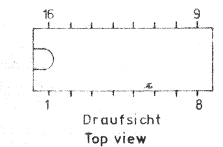
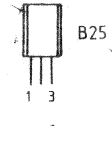
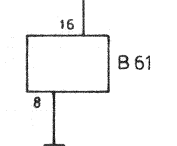
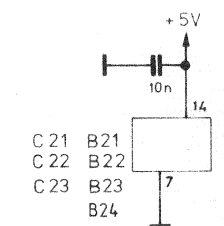
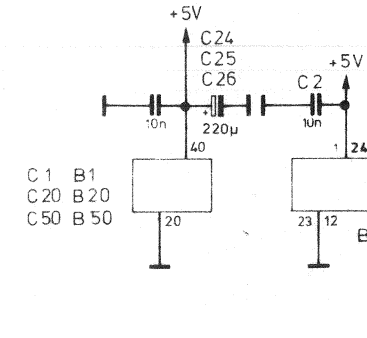
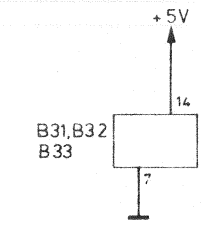

VERKLEINERUNG

 ROHDE & SCHWARZ MÜNCHEN		Halbzeug, Werkstoff		Untolerierte Maße		Zeichn. Nr. 355.9860 S	
1GME		Datum		Name		Maßstab 300:1000 V 300:1068	
gezeichnet		04.78		Sd		Erstz. / Zeichn.	
bearbeitet		2.80		Bg		Ansteuerung Drive stage	
geprüft							
normgepr.							



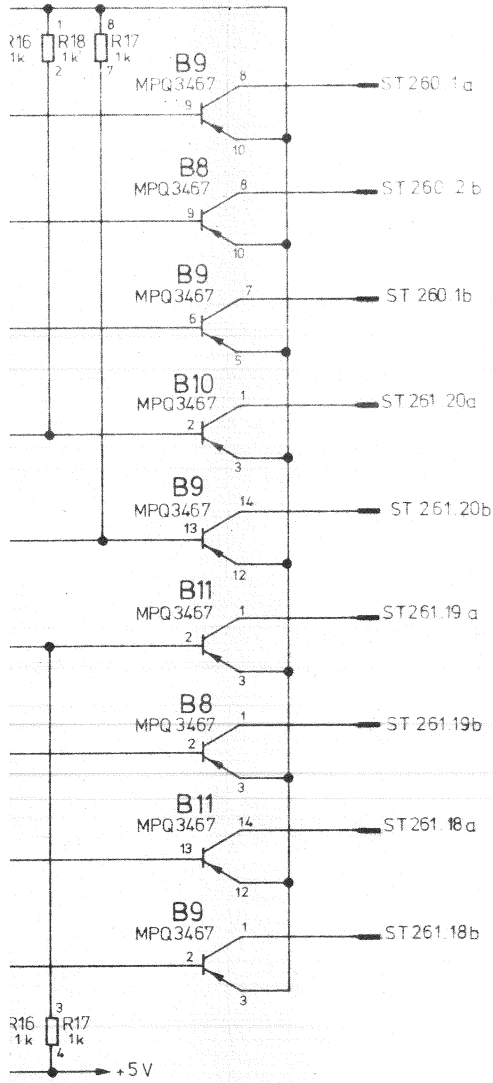

zum Anzeige- und Tastenfeld  
(Anzeige für HF-Frequenz und -Pegel)  
To indication and keyboard  
(Indication for RF-frequency and RF-level)

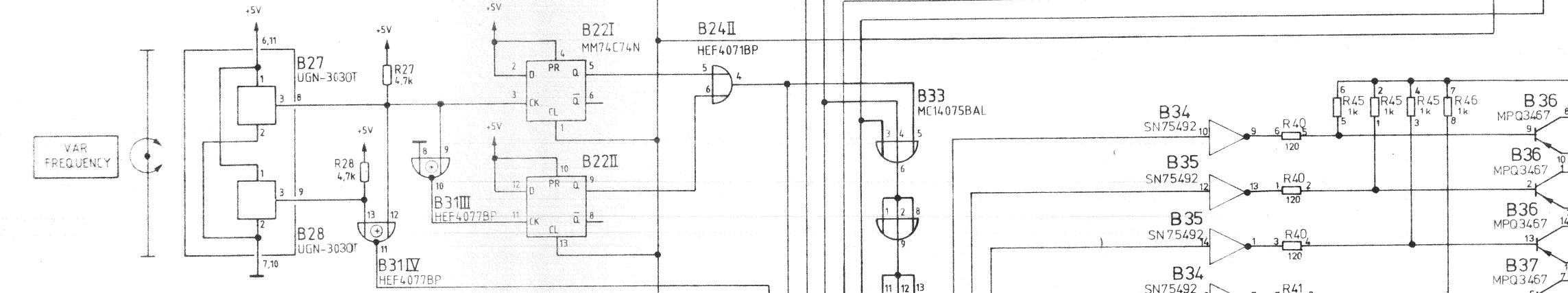
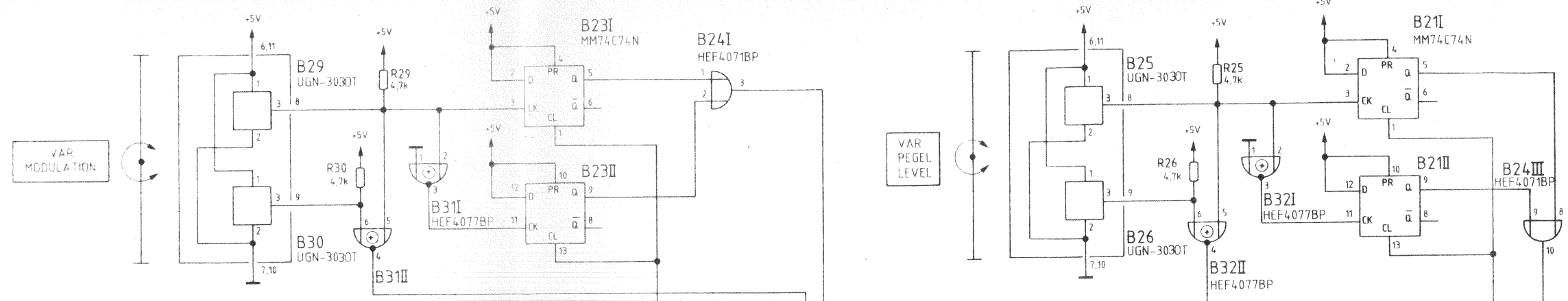

zum Anzeige- und Tastenfeld  
To indication and keyboard  
(Decoder für Anzeige und Leuchtdioden)  
(Decoder for display and LED)

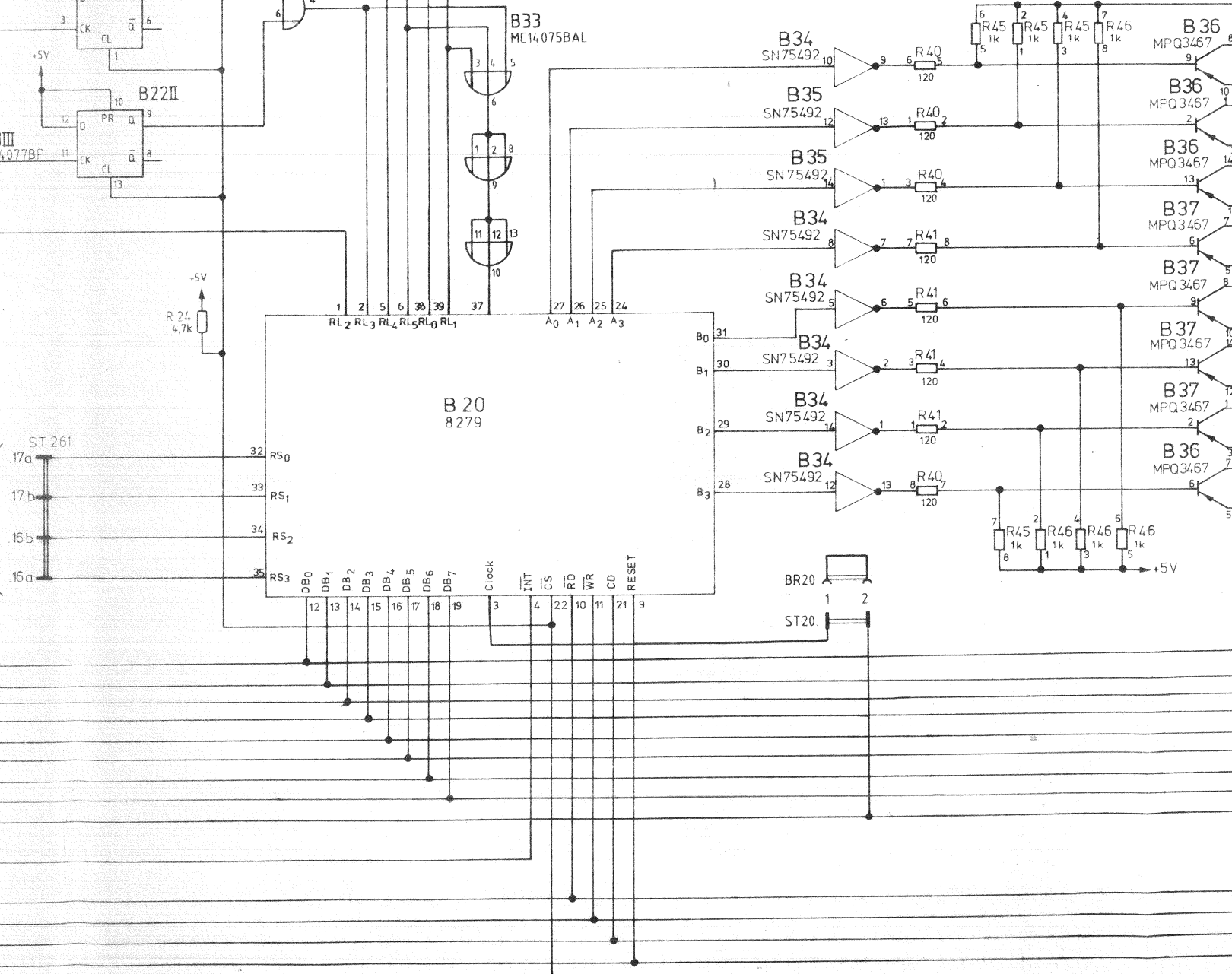

K271.2  
CS II  
(vom Rechner)

zum Anzeige- und Tastenfeld (HF-Anzeige) To indication and keyboard (RF-indication)

zum Anzeige und Tastenfeld (Tastenfeld) To indication and keyboard (keyboard)

vom Rechner From computer

zum Anzeige- und Tastenfeld / To indication and keyboard (Anzeige für HF-Frequenz, HF-Pegel / indication for RF-frequency, RF-level)

zum Anzeige- und Tastenfeld To indication and keyboard (Tastenfeld / keyboard)

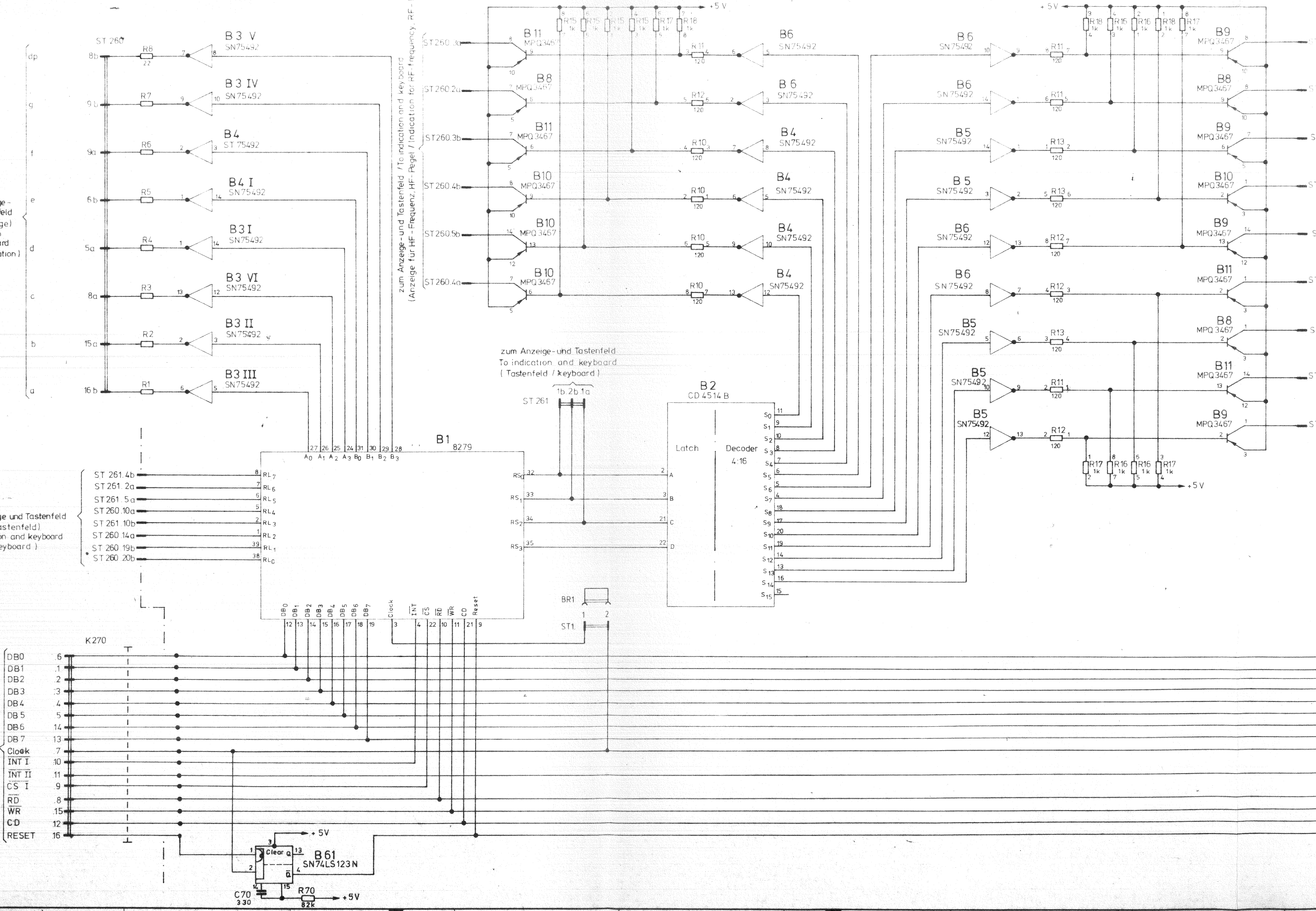



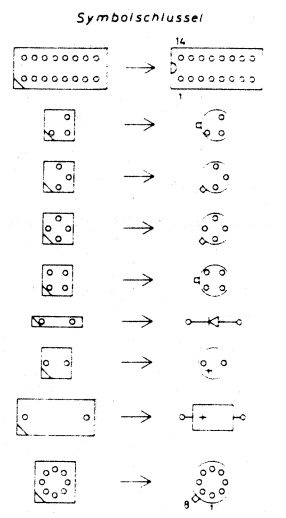
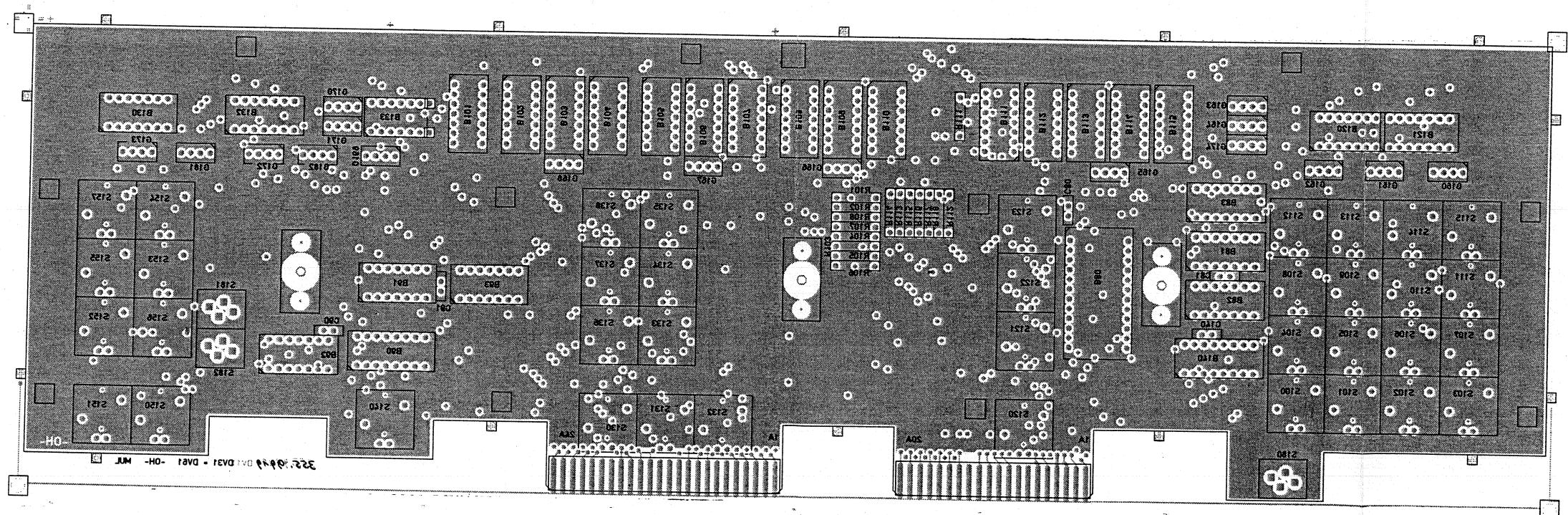

VERKLEINERUNG

Ansicht und Leitungsführung Lötseite  
View of tracks on solder side

Lage 1 DV11

Versorg.-Nr.		VG-Sachnr.	
Maße ohne Toleranzangabe		Maßstab 1 : 1	
Halbzeug, Werkstoff		Benennung	
1KGA	Tag	Name	Anzeige u. Tastenfeld Indication and keyboard
Bearb	8.83	IB	
Gepr			
Norm			
ROHDE & SCHWARZ MÜNCHEN		Zeichn.-Nr.	
zu Gerät SMPC		355.9902	
reg. i. V. 300.1000 V		erste Z. 300.1068	
And Zust	Änderungs-Mitteilung	Tag	Blatt-Nr. 2 v. 81

Für diese Zeichnung behalten wir uns alle Rechte vor.



2 3 4 5 6 7 8

A

B

C

D

E

F

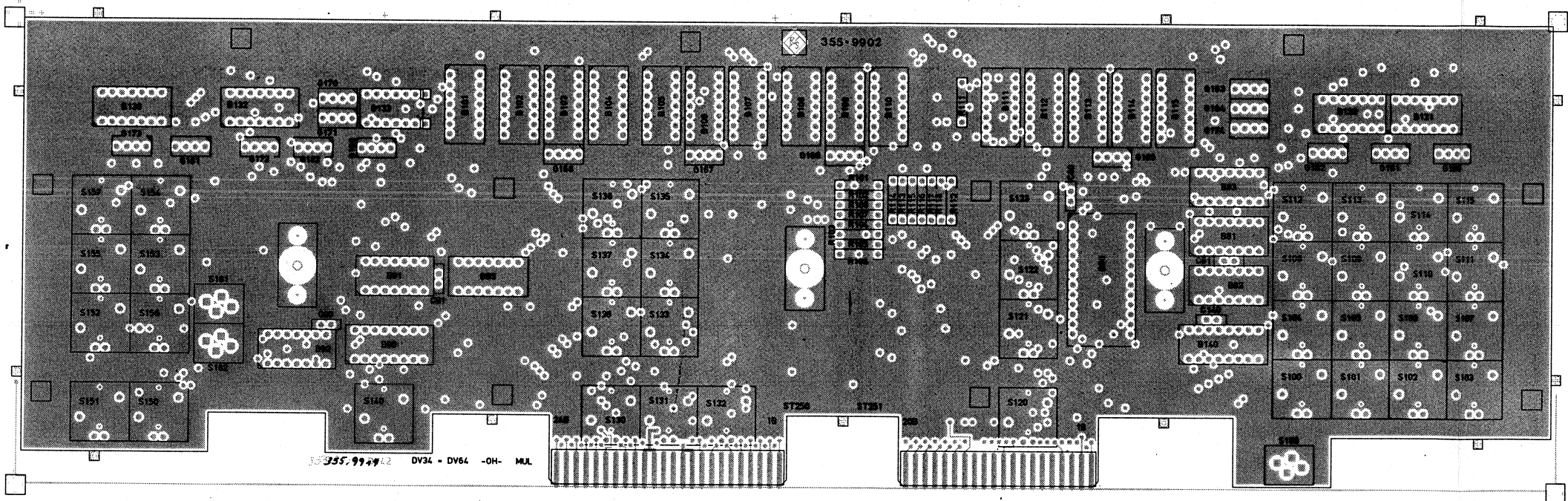

Symbolschlüssel

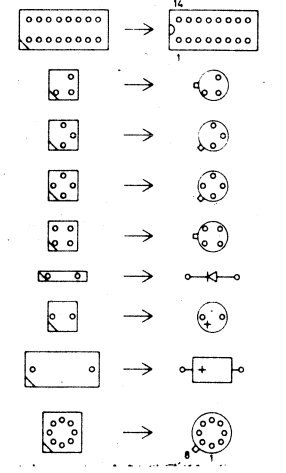

Ansicht und Leitungsführung Bauteilseite  
View of tracks on component side

Lage 4 DV42

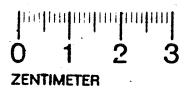

Für diese Zeichnung behalten wir uns alle Rechte vor.

Versorg-Nr		VG-Sachnr	
Maße ohne Toleranzangabe		Maßstab 1 : 1	
		Halbzeug, Werkstoff	
1 KGA	Tag	Name	Benennung
Bearb	8.83	IB	Anzeige u. Tastenfeld
Gepr			Indication and keyboard
Norm			
		Zeichn-Nr	
		355.9902	
		Blatt-Nr	
		5	
And. Zust.	Anderungs-Mitteilung	Tag	Name
		zu Gerät SMPC	
		reg. V 300.1000V	
		erste Z 300.1068	

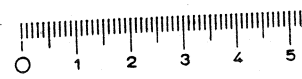
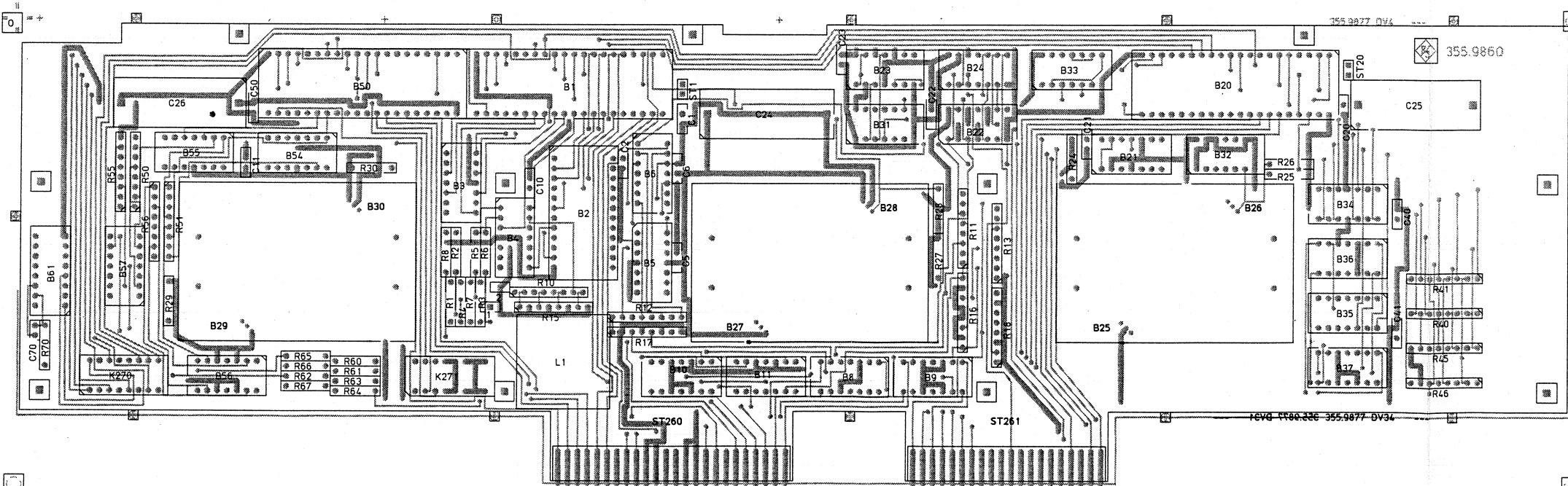

VERKLEINERUNG

Achtung! MOS-Bauteile  
Caution. MOS components

Ansicht und Leitungsführung Bauteilseite  
View of tracks on component side

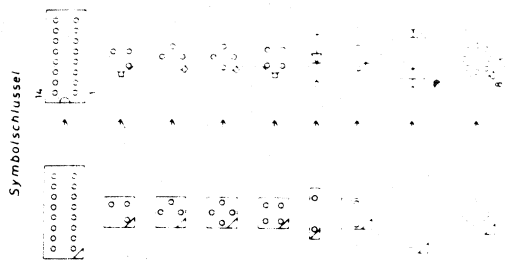

Maße ohne Toleranzangabe		Maßstab 1:1	
1KGA Tag Name		Halbzeug, Werkstoff	
Bearb. 2.83	LS	Benennung	
Gepr.		ANSTEUERUNG	
Norm		Drive stage	
ROHDE & SCHWARZ		Zeichn.-Nr.	
zu Gerät SMPC		355.9860	
reg. i. V. 355.9519 V		erste Z. 355.9519	
Blatt-Nr.	2	Z	
v. Bl.			

Für diese Unterlage behalten wir uns alle Rechte vor

ISO-Projektion Methode E

Für diese Unterlage behalten wir uns alle Rechte vor.

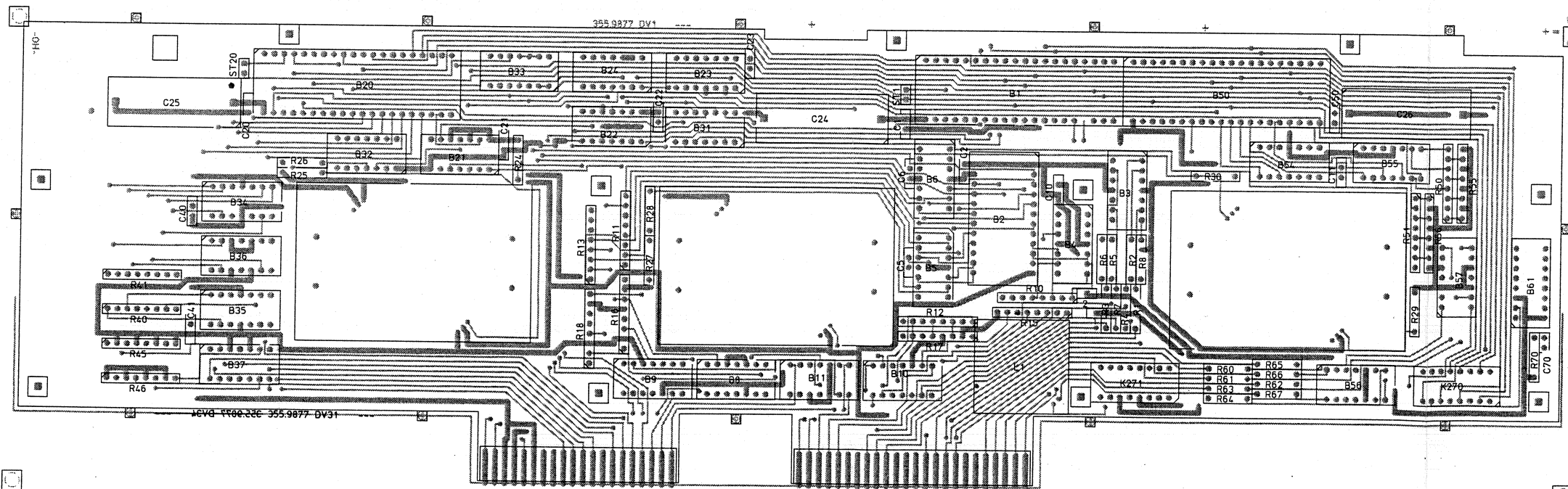

VERKLEINERUNG

Achtung! MOS-Bauteile  
Caution. MOS components

Ansicht und Leitungsführung Lötseite  
View of tracks on solder side

Symbolst. / Nusser

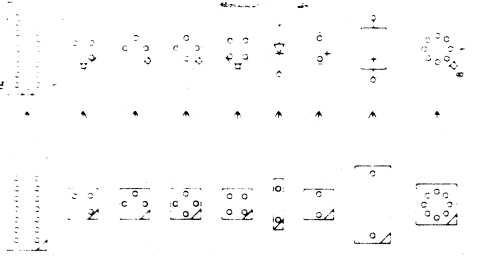

Maße ohne Toleranzangabe		Maßstab 1:1	
1KGA Tag Name		Halbzeug, Werkstoff	
Bearb. 2.83	Gepr.	Benennung	
Norm		ANSTEUERUNG	
		Drive stage	
		Zeichn.-Nr.	
		355.9860	
		Blatt-Nr.	
		3	
		v. Bl.	
And. Zust.	Anderungs-Mitteilung	Tag	Name
			zu Gerät SMPC
reg. i. V. 355.9519/V		erste Z. 355.9519	

Für diese Zeichnung behalten wir uns alle Rechte vor

Ansicht und Leitungsführung Bauteilseite  
View of tracks on component side

Ansteuerung  
Drive stage

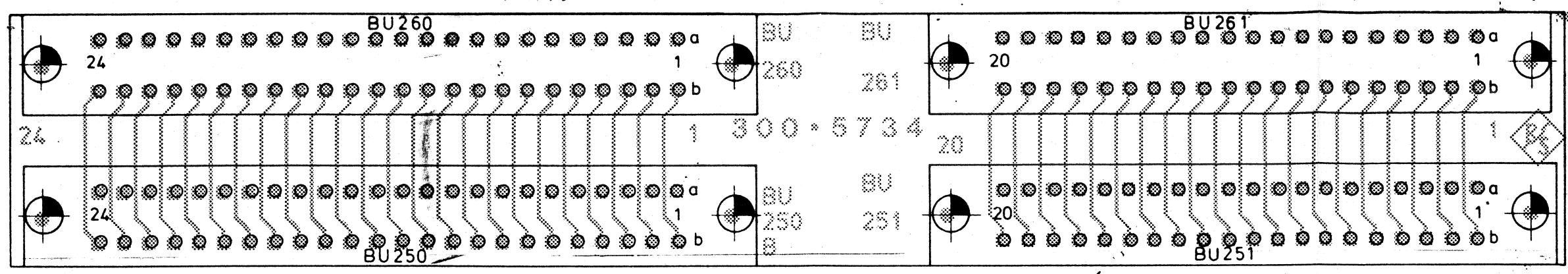

Tasten-u. Anzeigefeld  
Indication and keyboard

Ansicht und Leitungsführung Lötseite  
View of tracks on solder side

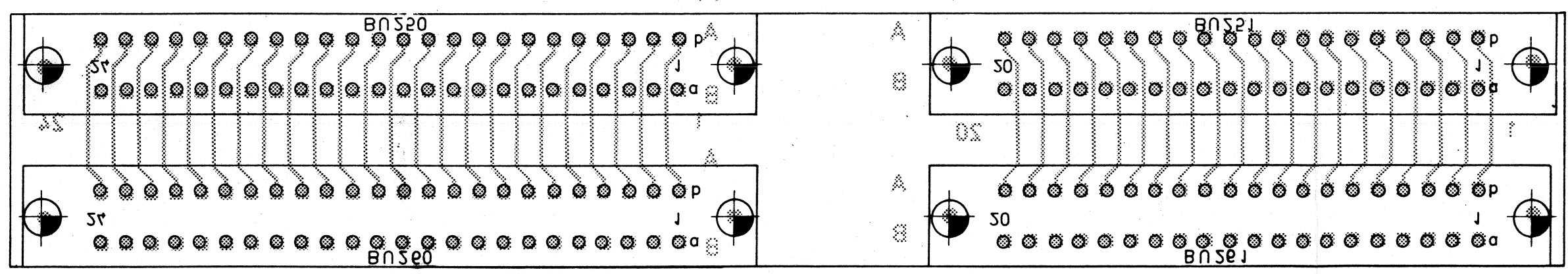

A		15.1.79	Wm.	Maße ohne Toleranzangabe	Maßstab 2:1	Z
					Halbzeug Werkstoff	
				IGME Tag Name	Benennung	
				Bearb. 15.1.79 Wm.	Verbindungsplatte Junction board	
				Gepr. 2.29 Bg		
				Norm		
				ROHDE & SCHWARZ MÜNCHEN	Zeichn. Nr. 300.5734	
And. Just.		Änderungs-Mittelung	Tag Name	zu Fertigen SMPC	300.1000V	Blatt-Nr. 2
					erste 300.1068	B



**ROHDE & SCHWARZ**

SERVICE INSTRUCTIONS FOR

Output Amplifier

300.1816 (Y20)

Table of Contents

	Page	
<u>5</u>	<u>Service Instructions for Output Amplifier</u>	
	<u>300.1816 (Y20)</u> .....	5.1
5.1	Circuit Description .....	5.1
5.2	Checking and Adjustment Procedures .....	5.1
5.2.1	Checking the Frequency Response .....	5.1
5.2.2	Checking the Harmonics .....	5.2
5.2.3	Checking the Broadband Noise .....	5.2
5.3	Troubleshooting .....	5.2
5.3.1	Interfaces .....	5.3

Parts list  
Circuit diagram  
Components location plan

### 5.1 Circuit Description

(See circuit diagram 300.1816 S)

Y20 consists of four amplifier stages (T2, T22, T42, T62) the operating points of which are controlled by auxiliary transistors (T1, T21, T41, T62).

The auxiliary transistor T1 controls the current drain of the RF transistor T2 via the base of the latter so that the voltage drop across the precision resistor R7 corresponds to the nominal value given by a voltage divider (R5, R6). The last two stages are temperature-compensated by means of GL40 and GL60.

### 5.2 Checking and Adjustment Procedures

#### 5.2.1 Checking the Frequency Response

Test setup:

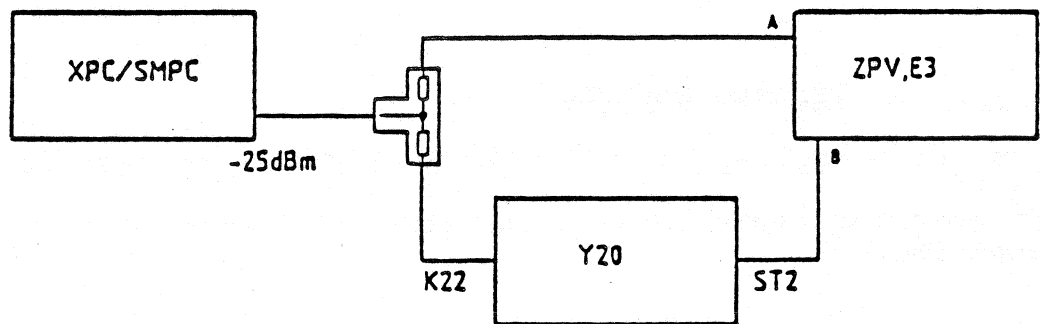

Fig. 5-1 shows the typical frequency response and the tolerance limits.

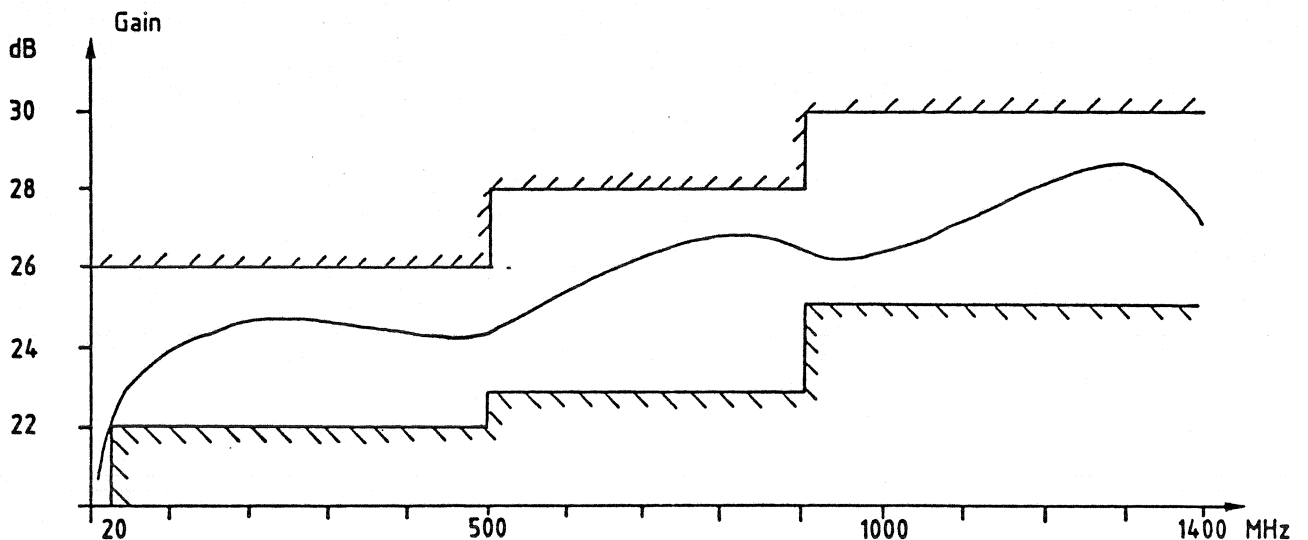

Fig. 5-1 Typical curve and tolerance



### 5.2.2 Checking the Harmonics

Feed 21 to 1360 MHz with a harmonic content  $< -36$  dBc to K22. Measure harmonics at ST2 by means of RF analyzer.  $-25$  dBc must not be exceeded at the settings listed in Table 5-1.

Table 5-1

Frequency/MHz	200	500	1000	1360
Level at ST2/dBm	21	22	22.5	23.5

### 5.2.3 Checking the Broadband Noise

Terminate the input (K22) with  $50 \Omega$ . Connect spectrum analyzer to output (ST2). The measured noise power should not exceed  $-130$  dBm referred to 1 Hz bandwidth.

### 5.3 Troubleshooting

The collector voltage at all four RF transistors must be  $16 \pm 1$  V.

Check coupling capacitors in the case of frequency drifts at low frequencies.

**5.3.1 Interfaces**

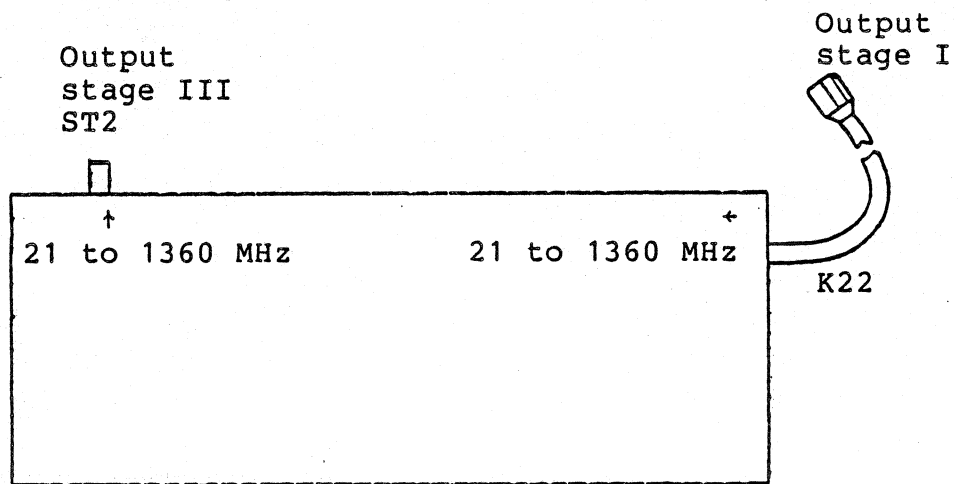

K/ST/BU	K22	ST2
f	21 to 1360 MHz	21 to 1360 MHz
Level	-7 to -2 dBm	19 to 23 dBm
Z	50 Ω	not defined load 50 Ω
AC-DC	AC	AC
Shape of curve	sinusoidal	sinusoidal



ROHDE & SCHWARZ  
MÜNCHEN

Schaltteillisten  
Stromläufe  
Bestückungspläne  
Parts lists  
Circuit diagrams  
Components plans

**ROHDE & SCHWARZ**ÄI Datum  
Date  
12 0487Schaltteilliste für  
Parts list for  
ZE AUSGANGSVERSTAERKER  
OUTPUT AMPLIFIERSachnummer  
Stock No.  
300.1816.01 SABlatt  
Page  
1

Kennzeichen Component No.	Benennung/Beschreibung Designation	Sachnummer Stock No.	enthalten in contained in
C1	CC 680PF+-10%4X5R2000 CAPACITOR VALVO 2222 63051 681	CC 087.7019	
C2	CC 1,5NF-20+80%R10000TRAP CAPACITOR STETTNER TEFK7,1500/2080E9000	CC 082.1712	300.5792.01
C3	CC 1UF +-10% 50VK1200LR CAPACITOR AEROVOX CKR06BX105KLEVELR	CC 092.1015	300.5792.01
C4	CC 1,5NF-20+80%R10000TRAP CAPACITOR STETTNER TEFK7,1500/2080E9000	CC 082.1712	300.5792.01
C5	CC 1NF+-10%100V3K1200CHIP CAPACITOR VITRAMON VJ1005Y102KFB	CC 082.3221	300.5792.01
C6	CC 3,2PF+-0,25PF50V2NPO CAPACITOR VITRAMON VJ0805A3R2CFA	CC 093.5595	300.5792.01
C7	CC 3,2PF+-0,25PF50V2NPO CAPACITOR VITRAMON VJ0805A3R2CFA	CC 093.5595	300.5792.01
C8	TRIMMWERT / SELECTED 3,2PF / CC093.5595		
C21	CC 680PF+-10%4X5R2000 CAPACITOR VALVO 2222 63051 681	CC 087.7019	
C22	CC 1,5NF-20+80%R10000TRAP CAPACITOR STETTNER TEFK7,1500/2080E9000	CC 082.1712	300.5792.01
C23	CC 1UF +-10% 50VK1200LR CAPACITOR AEROVOX CKR06BX105KLEVELR	CC 092.1015	300.5792.01
C24	CC 1,5NF-20+80%R10000TRAP CAPACITOR STETTNER TEFK7,1500/2080E9000	CC 082.1712	300.5792.01
C25	CC 1NF+-10%100V3K1200CHIP CAPACITOR VITRAMON VJ1005Y102KFB	CC 082.3221	300.5792.01
C26	CC 8,8PF+- 2%100V NPO CHI CERAMIC CAPACITOR VITRAMON VJ0805A8R8CFA	CC 022.0790	300.5792.01
C27	CC 8,8PF+- 2%100V NPO CHI CERAMIC CAPACITOR VITRAMON VJ0805A8R8CFA	CC 022.0790	300.5792.01
C28	TRIMMWERT / SELECTED 3,2PF / CC093.5595		
C41	CC 680PF+-10%4X5R2000 CAPACITOR VALVO 2222 63051 681	CC 087.7019	
C42	CC 1,5NF-20+80%R10000TRAP CAPACITOR STETTNER TEFK7,1500/2080E9000	CC 082.1712	300.5792.01
C43	CC 1UF +-10% 50VK1200LR CAPACITOR AEROVOX CKR06BX105KLEVELR	CC 092.1015	300.5792.01

300.1816.01 SA BL 1+

Für diese Unterlage behalten wir  
uns alle Rechte vor

 <b>ROHDE &amp; SCHWARZ</b>	Äl	Datum Date	Schaltteilliste für Parts list for	Sachnummer Stock No.	Blatt Page
	12	0487	ZE AUSGANGSVERSTAERKER OUTPUT AMPLIFIER	300.1816.01 SA	2

Kennzeichen Component No.	Benennung/Beschreibung Designation	Sachnummer Stock No.	enthalten in contained in
C44	CC 1,5NF-20+80ZR10000TRAP CAPACITOR STETTNER TEFK7,1500/2080E9000	CC 082.1712	300.5792.01
C45	CC 1NF+-10%100V3K1200CHIP CAPACITOR VITRAMON VJ1005Y102KFB	CC 082.3221	300.5792.01
C46	CC 2,1PF+-0,25PF50V2NPO CAPACITOR VITRAMON VJ0805A2R1CFA	CC 093.5550	300.5792.01
C47	CC 2,1PF+-0,25PF50V2NPO CAPACITOR VITRAMON VJ0805A2R1CFA	CC 093.5550	300.5792.01
C61	CC 680PF+-10%4X5R2000 CAPACITOR VALVO 2222 63051 681	CC 087.7019	
C62	CC 1,5NF-20+80ZR10000TRAP CAPACITOR STETTNER TEFK7,1500/2080E9000	CC 082.1712	300.5792.01
C63	CC 1UF +-10% 50VK1200LR CAPACITOR AEROVOX CKR06BX105KLEVELR	CC 092.1015	300.5792.01
C64	CC 1,5NF-20+80ZR10000TRAP CAPACITOR STETTNER TEFK7,1500/2080E9000	CC 082.1712	300.5792.01
C65	CC 1NF+-10%100V3K1200CHIP NUR VAR : 02 CAPACITOR VITRAMON VJ1005Y102KFB	CC 082.3221	300.5792.01
C65	CC 3,0PF+-0,25PF50V NPO C NUR VAR : 04 CERAMIC CHIP CAPACITOR VITRAMON VJ0805A3R0CFA	CC 099.8267	300.5792.01
C66	CC 680PF+-10%4X5R2000 CAPACITOR VALVO 2222 63051 681	CC 087.7019	
C67	CC 4,7PF+-0,5PF100V3NPO C CAPACITOR VITRAMON VJ1005A4R7DFB	CC 082.2977	300.5792.01
C68	CC 4,7PF+-0,5PF100V3NPO C NUR VAR : 02 CAPACITOR VITRAMON VJ1005A4R7DFB	CC 082.2977	300.5792.01
C68	CC 56PF+-10%50V NPO 0805 NUR VAR : 04 CERAMIC CHIP CAPACITOR VITRAMON VJ0805A560KFA	CC 099.8344	300.5792.01
C69	CC 6,8PF+-0,5PF50V1NPO NUR VAR : 02 CAPACITOR VITRAMON VJ0805A6R8CFA	CC 093.2167	300.5792.01
C69	TRIMMWERT / SELECTED NUR VAR : 04		300.5792.01
C70	CE 22 UF-10+75% 40V 8X29J ELECTROLYTIC CAPACITOR SPRAGUE ELK0600D226G050KD5	CE 084.5896	300.5792.01

300.1816.01 SA BL 2+

**ROHDE & SCHWARZ**

Äl

Datum  
DateSchaltteilliste für  
Parts list forSachnummer  
Stock No.Blatt  
Page

12

0487

ZE AUSGANGSVERSTAERKER  
OUTPUT AMPLIFIER

300.1816.01 SA

3

Kennzeichen Component No.	Benennung/Beschreibung Designation	Sachnummer Stock No.	enthalten in contained in
D1	LD 38 DB BEI 10GHZ 1750PF LEAD-THROUGH FILTER ERIE 1214-001	LD 037.8011	300.1822
GL40	AD 1N4151 50V 0,2 A UDI DIODE	AD 012.0723	300.5792.01
GL60	AD 1N4151 50V 0,2 A UDI DIODE AEG-TELEF. 1N4151	AD 012.0723	300.5792.01
K22	DX HF-KABEL RF-CABLE	300.8262	
K200	DX BANDLEITUNG RIBBON-CABLE	337.8650	
L1	LD SPULE COIL	337.8208	300.5792.01
L2	ENTHALTEN IN/INCLUDED IN LEITERPLATTE/PCB		300.5792.01
L21	LD SPULE COIL	337.8208	300.5792.01
L22	ENTHALTEN IN/INCLUDED IN LEITERPLATTE/PCB		300.5792.01
L41	LD SPULE COIL	337.8208	300.5792.01
L42	ENTHALTEN IN/INCLUDED IN LEITERPLATTE/PCB		300.5792.01
L61	LD SPULE COIL	337.8208	300.5792.01
L62	ENTHALTEN IN/INCLUDED IN LEITERPLATTE/PCB		300.5792.01
L70	LD 6UH1,5A0,190HM RD5X17 CHOKE SIEMENS B82131-A5152-M	007.7330	
R1	RL 0,21W 2,21KOHM+-1%TK50 RESISTOR	RL 092.1480	300.5792.01
R2	RESISTA MK1 2K21 1% TK50 RG 0,125W 33 OHM+-1% CHIP CHIP RESISTOR	337.8214	300.5792.01
R3	MSI WA-4 330HM 1% PG-T RG 0,125W 180 OHM+-1%CHIP NUR VAR : 02 CHIP RESISTOR	337.8220	300.5792.01
R3	MSI WA-4 1800HM 1% PS-T RG 82,5 OHM+-1%TK100 1206 NUR VAR : 04 CHIP RESISTOR	RG 006.8861	300.5792.01
R4	DALE CRCW1206 82,50HM F T RG 0,5W147 OHM+-2%TK100 RESISTOR	083.3748	300.5792.01
R5	VITROHM RGU1500HM2%RN2,5 RL 0,35W 10,0KOHM+-1%TK50 RESISTOR DRALORIC SMA0207/10K-F-D	RL 083.1297	300.5792.01

300.1816.01 SA RL 3+

Für diese Unterlage behalten wir  
uns alle Rechte vor

Kennzeichen Component No.	Benennung/Beschreibung Designation	Sachnummer Stock No.	enthalten in contained in
R6	RL 0,35W 1KOHM+-1%TK50 RESISTOR DRALORIC SMA0207/1K-F-C	RL 082.2160	300.5792.01
R7	RL 0,35W 10,0 OHM+-1%TK50 RESISTOR DRALORIC SMA0207/100HM-F-D	RL 082.8852	300.5792.01
R8	RG 0,5W 47 OHM+-2%TK100 METAL-GLAZE RESISTOR VITROHM RGU470HM2%RM2,5	080.1109	300.5792.01
R9	RG 0,125W 10 OHM+-1% CHIP CHIP RESISTOR MSI WA-4 100HM 1% PG-T	337.8237	300.5792.01
R10	RG 0,125W 10 OHM+-1% CHIP CHIP RESISTOR MSI WA-4 100HM 1% PG-T	337.8237	300.5792.01
R11	RG 0,5W 47 OHM+-2%TK100 METAL-GLAZE RESISTOR VITROHM RGU470HM2%RM2,5	080.1109	300.5792.01
R21	RL 0,21W 2,21KOHM+-1%TK50 RESISTOR RESISTA MK1 2K21 1% TK50	RL 092.1480	300.5792.01
R22	RG 0,125W 27 OHM+-1% CHIP CHIP RESISTOR MSI WA-4 270HM 1% PG-T	337.8243	300.5792.01
R23	RG 0,125W 180 OHM+-1%CHIP NUR VAR : 02 CHIP RESISTOR MSI WA-4 1800HM 1% PS-T	337.8220	300.5792.01
R23	RG 121 OHM+-1%TK100 1206 NUR VAR : 04 CHIP RESISTOR DALE CRCW1206 1210HM F T	RG 006.8903	300.5792.01
R24	RG 0,5W147 OHM+-2%TK100 RESISTOR VITROHM RGU1500HM2%RN2,5	083.3748	300.5792.01
R25	RL 0,35W 10,0KOHM+-1%TK50 RESISTOR DRALORIC SMA0207/10K-F-D	RL 083.1297	300.5792.01
R26	RL 0,35W 1KOHM+-1%TK50 RESISTOR DRALORIC SMA0207/1K-F-C	RL 082.2160	300.5792.01
R27	RL 0,35W 10,0 OHM+-1%TK50 RESISTOR DRALORIC SMA0207/100HM-F-D	RL 082.8852	300.5792.01
R28	RG 0,5W 47 OHM+-2%TK100 METAL-GLAZE RESISTOR VITROHM RGU470HM2%RM2,5	080.1109	300.5792.01
R29	RG 0,125W 22 OHM+-1% MSJ RESISTOR MSI WA-7 220HM 1% PG-T	337.8266	300.5792.01
R30	RG 0,125W 22 OHM+-1% MSJ RESISTOR MSI WA-7 220HM 1% PG-T	337.8266	300.5792.01
R31	RG 0,5W 47 OHM+-2%TK100 METAL-GLAZE RESISTOR VITROHM RGU470HM2%RM2,5	080.1109	300.5792.01



**ROHDE & SCHWARZ**AI  
Datum  
Date  
12 0487Schaltteilliste für  
Parts list for  
ZE AUSGANGSVERSTAERKER  
OUTPUT AMPLIFIERSachnummer  
Stock No.

300.1816.01 SA

Blatt  
Page

5

Kennzeichen Component No.	Benennung/Beschreibung Designation	Sachnummer Stock No.	enthalten in contained in
R41	RL 0,21W 2,21KOHM+-1%TK50 RESISTOR	RL 092.1480	300.5792.01
R43	RESISTA MK1 2K21 1% TK50 RG 0,125W 220 OHM+-1%CHIP CHIP RESISTOR	337.8250	300.5792.01
R44	MSI WA-4 220OHM 1% PS-T RG 0,5W147 OHM+-2%TK100 RESISTOR	083.3748	300.5792.01
R45	VITROHM RGU150OHM2%RN2,5 RL 0,35W 15,0KOHM+-1%TK50 RESISTOR	RL 083.1400	300.5792.01
R46	DRALORIC SMA0207/15K-F-D RL 0,35W 1KOHM+-1%TK50 RESISTOR	RL 082.2160	300.5792.01
R47	DRALORIC SMA0207/1K-F-C RL 0,35W 10,0 OHM+-1%TK50 RESISTOR	RL 082.8852	300.5792.01
R48	DRALORIC SMA0207/100HM-F-D RG 0,5W 47 OHM+-2%TK100 METAL-GLAZE RESISTOR	080.1109	300.5792.01
R49	VITROHM RGU470HM2%RM2,5 RG 0,5W 33 OHM+-1% CHIP RESISTOR	337.8272	300.5792.01
R50	MSI WA-7 330HM 1% PG-T RG 0,5W 33 OHM+-1% CHIP RESISTOR	337.8272	300.5792.01
R51	MSI WA-7 330HM 1% PG-T RG 0,5W 47 OHM+-2%TK100 METAL-GLAZE RESISTOR	080.1109	300.5792.01
R61	VITROHM RGU470HM2%RM2,5 RL 0,21W 2,21KOHM+-1%TK50 RESISTOR	RL 092.1480	300.5792.01
R62	RESISTA MK1 2K21 1% TK50 RG 0,125W 33 OHM+-1% CHIP CHIP RESISTOR	337.8214	300.5792.01
R63	MSI WA-4 330HM 1% PG-T RG 0,125W 220 OHM+-1%CHIP NUR VAR : 02 CHIP RESISTOR	337.8250	300.5792.01
R63	MSI WA-4 220OHM 1% PS-T RG 261 OHM+-2%TK200 1206 NUR VAR : 04 CHIP RESISTOR	RG 006.8984	300.5792.01
R64	DRALORIC CGE3216 2610HM2% TK. RG 0,5W147 OHM+-2%TK100 RESISTOR	083.3748	300.5792.01
R65	VITROHM RGU150OHM2%RN2,5 RL 0,35W 15,0KOHM+-1%TK50 RESISTOR	RL 083.1400	300.5792.01
R66	DRALORIC SMA0207/15K-F-D RL 0,35W 1KOHM+-1%TK50 RESISTOR	RL 082.2160	300.5792.01
R67	DRALORIC SMA0207/1K-F-C RL 0,35W 10,0 OHM+-1%TK50 RESISTOR DRALORIC SMA0207/100HM-F-D	RL 082.8852	300.5792.01

300.1816.01 SA BL 5+

Für diese Unterlage behalten wir  
uns alle Rechte vor



ROHDE & SCHWARZ

AI Datum  
Date  
12 0487

Schaltteilliste für  
Parts list for  
ZE AUSGANGSVERSTAERKER  
OUTPUT AMPLIFIER

Sachnummer  
Stock No.  
300.1816.01 SA

Blatt  
Page  
6

Kennzeichen Component No.	Benennung/Beschreibung Designation	Sachnummer Stock No.	enthalten in contained in
R68	RG 0,5W 47 OHM+-2%TK100 METAL-GLAZE RESISTOR VITROHM RGU470HM2%RM2,5	080.1109	300.5792.01
R69	RG 0,5W 39 OHM+-1% CHIP RESISTOR MSI WA-7 390HM 1% PG-T	337.8289	300.5792.01
R70	RG 0,5W 39 OHM+-1% CHIP RESISTOR MSI WA-7 390HM 1% PG-T	337.8289	300.5792.01
R71	RG 0,5W 47 OHM+-2%TK100 METAL-GLAZE RESISTOR VITROHM RGU470HM2%RM2,5	080.1109	300.5792.01
R72	RL 0,35W 100 OHM+-1%TK50 NUR VAR : 04 METALFILM-RESISTOR DRALORIC SMA0207/100/HM-F-D	RL 082.6543	300.5792.01
ST2	FJ EINBAUWINKELST. SMC ANGLE CONNECTOR RADIALL R 112 669	FJ 249.9684	300.5792.01
T1	AK BCY79IX PNP 45V 200MA TRANSISTOR SIEMENS BCY79IX	AK 010.3777	300.5792.01
T2	AK BFQ 34 TRANSISTOR	337.8195	300.5792.01
T21	AK BCY79IX PNP 45V 200MA TRANSISTOR SIEMENS BCY79IX	AK 010.3777	300.5792.01
T22	AK BFQ 34 TRANSISTOR	337.8195	300.5792.01
T41	AK BCY79IX PNP 45V 200MA TRANSISTOR SIEMENS BCY79IX	AK 010.3777	300.5792.01
T42	AK BFQ 34 TRANSISTOR	337.8195	300.5792.01
T61	AK BCY79IX PNP 45V 200MA TRANSISTOR SIEMENS BCY79IX	AK 010.3777	300.5792.01
T62	AK BFQ34SEL NPN 18V 150MA TRANSISTOR VALVO BFQ34/R&S-LV	562.0167	300.5792.01

- ENDE -

300.1816.01 SA BL 6-

\*) nur für VAR 04  
only for model 04

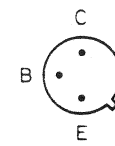
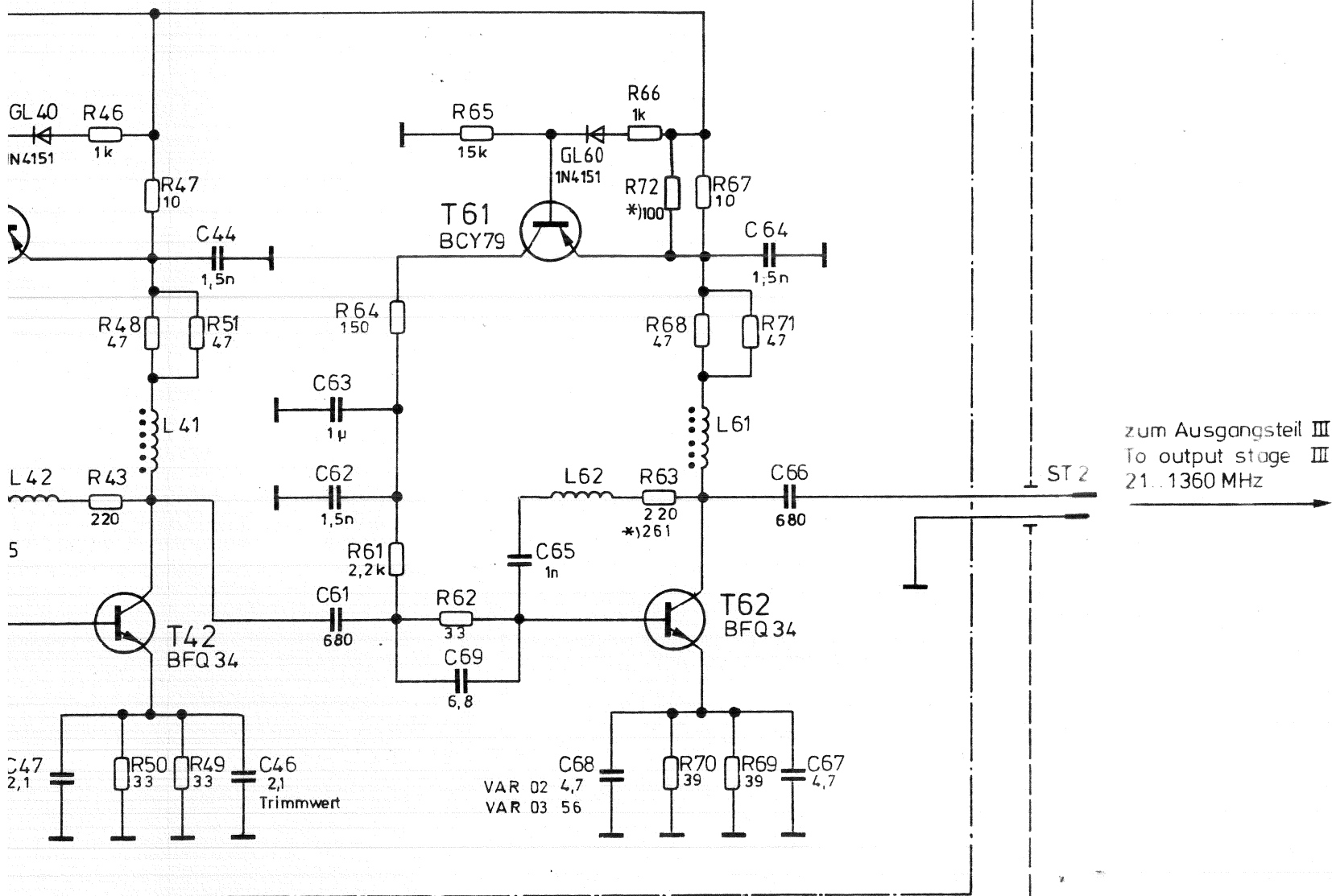

T1, T21, T41, T61

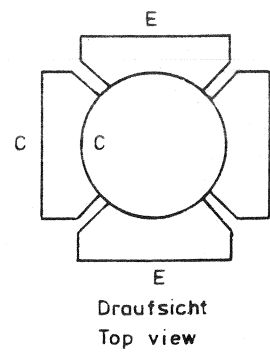

T2, T22, T42, T62

Stromlauf gilt für VAR 02, 04  
Circuit diagram is valid for model 02, 04

	Stromlauf zu	Ausgangsverstärker	Zeichn. Nr. 300.1816 S	
		Output amplifier	300.1000V	300.1000

And. Nr.		
Datum		
Name		
32288	3.85	GS
32912	4.86	GS
35536	4.87	LS

Diese Zeichnung ist unser Eigentum. Vervielfältigung, unbefugte Verwertung, Mitteilung an andere ist strafbar und schadensersatzpflichtig.

ROHDE & SCHWARZ MÜNCHEN

1GMA					
gezeichnet	79	Gü	D1	5.79	DI
geprüft	5.79	D1	LS	5.81	LS
revisiert	2.80			4.82	ib
				9.83	gs
				8.84	CO

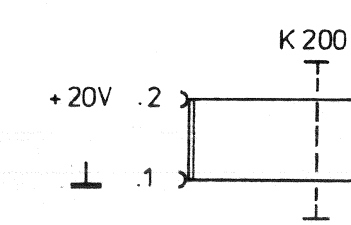
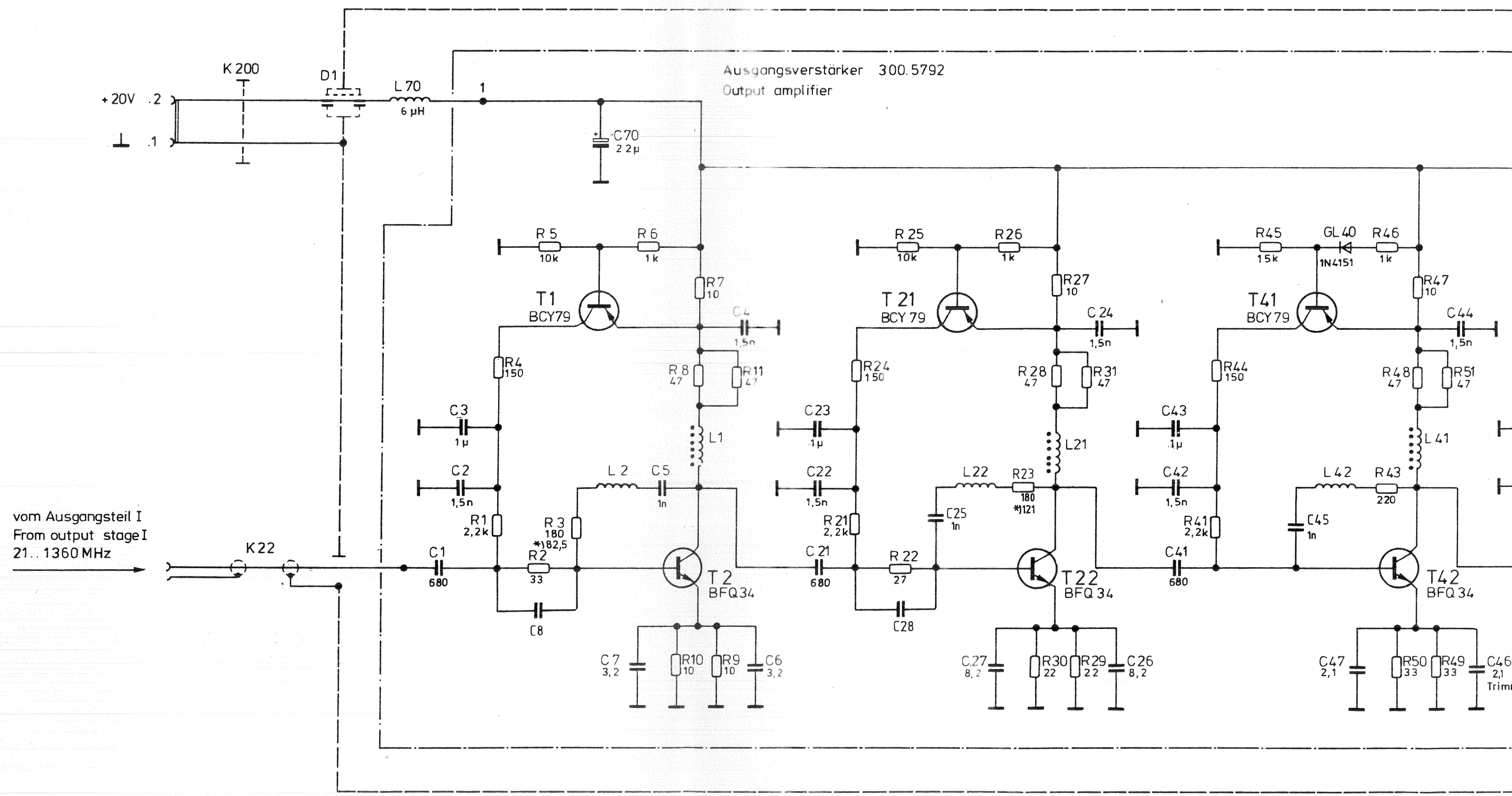

vom Ausgangsteil I  
From output stage I  
21...1360 MHz

C46  
2,1  
Trimm



Für diese Zeichnung behalten wir uns alle Rechte vor.

A B C D E F

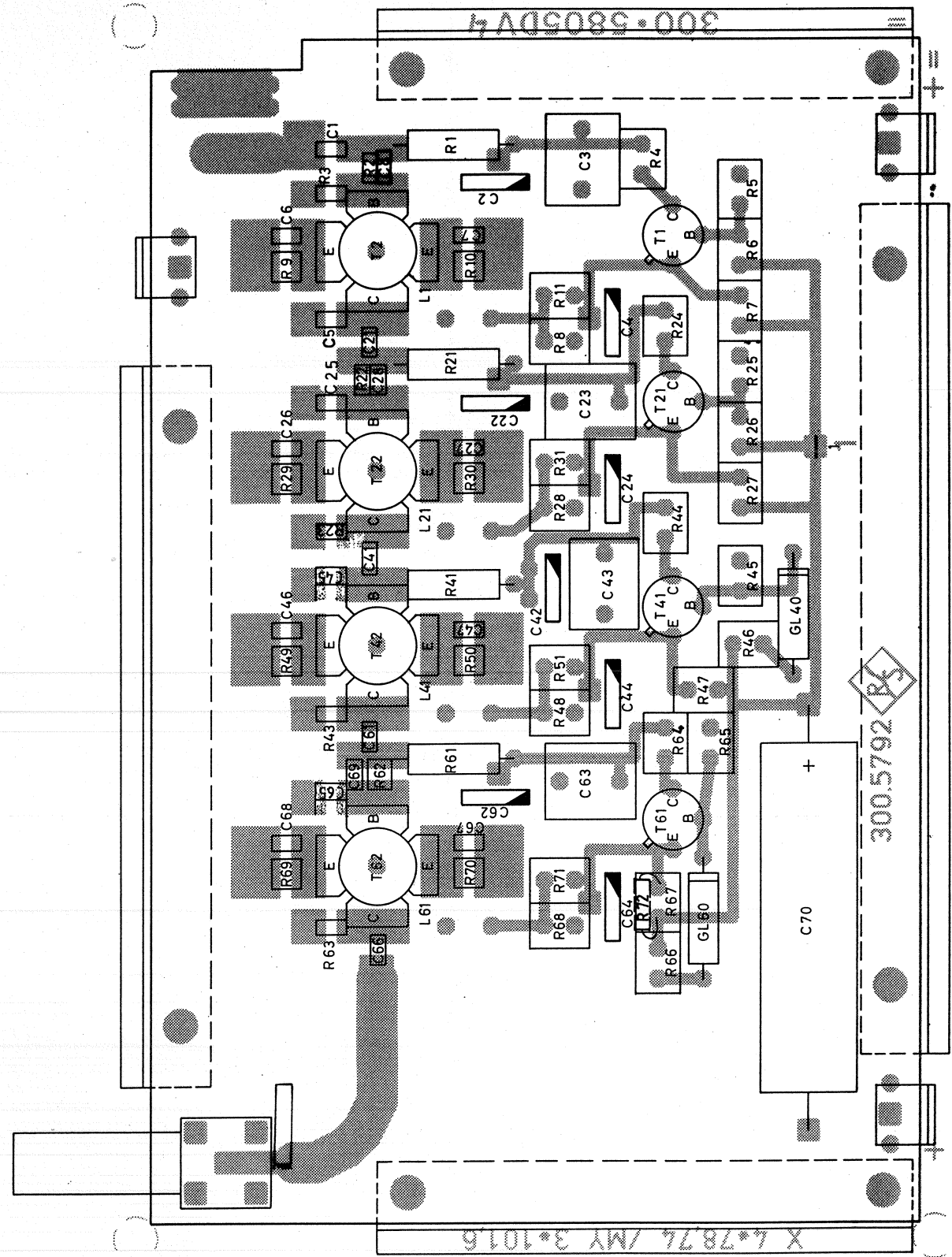

Ansicht und Leitungsführung Bauteilseite  
View of tracks on component side

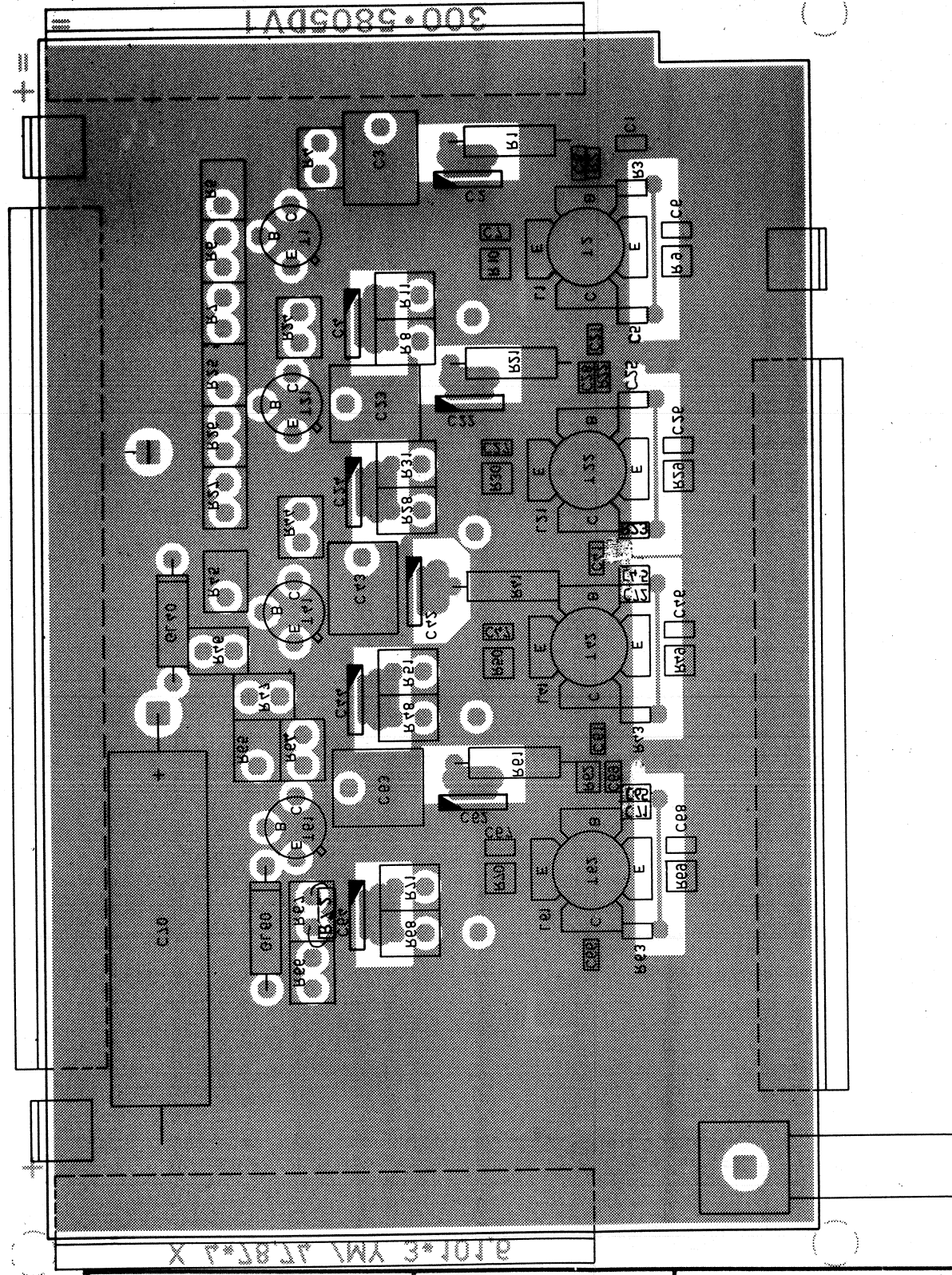

Ansicht und Leitungsführung Lötseite  
View of tracks on solder side

Versorg-Nr		Vg-Sachnr	
C	27499	6.81	LS
D	27860	11.82	LS
G	32288	8.84	IB
H	32942	6.86	GS
J	35536	4.87	LS
Maße ohne Toleranzangabe		Maßstab 1:1	
1GM Tag Name		Halbzeug Werkstoff	
Bearb	6.81	LS	Benennung <b>Ausgangsverstärker</b> Output amplifier
Gepr			
Norm			
ROHDE & SCHWARZ MÜNCHEN		Blatt-Nr. 2	
Zu Gerät SMPC		300.5792	
And. Zust.		300.1000 V	
Änderungs-Mitteilung		300.1816	
Tag		v. Bl.	



**ROHDE & SCHWARZ**

SERVICE INSTRUCTIONS

Power Supply

376.8511 (Y25)

Printed in West Germany

# Table of Contents

		Page
<u>5</u>	<u>Service Instructions for Power Supply</u>	
	<u>376.8511 (Y25)</u> .....	5.1
5.1	Circuit Description .....	5.1
5.1.1	Switching Power Supply .....	5.2
5.1.2	Series-regulated Power Supply I .....	5.2
5.1.3	Series-regulated Power Supply II .....	5.2
5.2	Checking and Adjustment Procedures .....	5.3
5.2.1	Checking the Supply Voltages .....	5.3
5.2.2	Adjustment of the Supply Voltages .....	5.3
5.3	Troubleshooting .....	5.4
5.3.1	Switching Power Supply .....	5.4
5.3.1.1	Checking the Control Chip B101 .....	5.4

Parts list  
Circuit diagram  
Components location plan



### 5.1 Circuit Description

(See circuit diagram 376.8511 S and Fig. 5-1)

The power supply of the SMPD consists of two conventional power supply sections made up of a toroidal transformer and series regulators, and a switching power supply section switched at the primary side for voltages with higher loads.

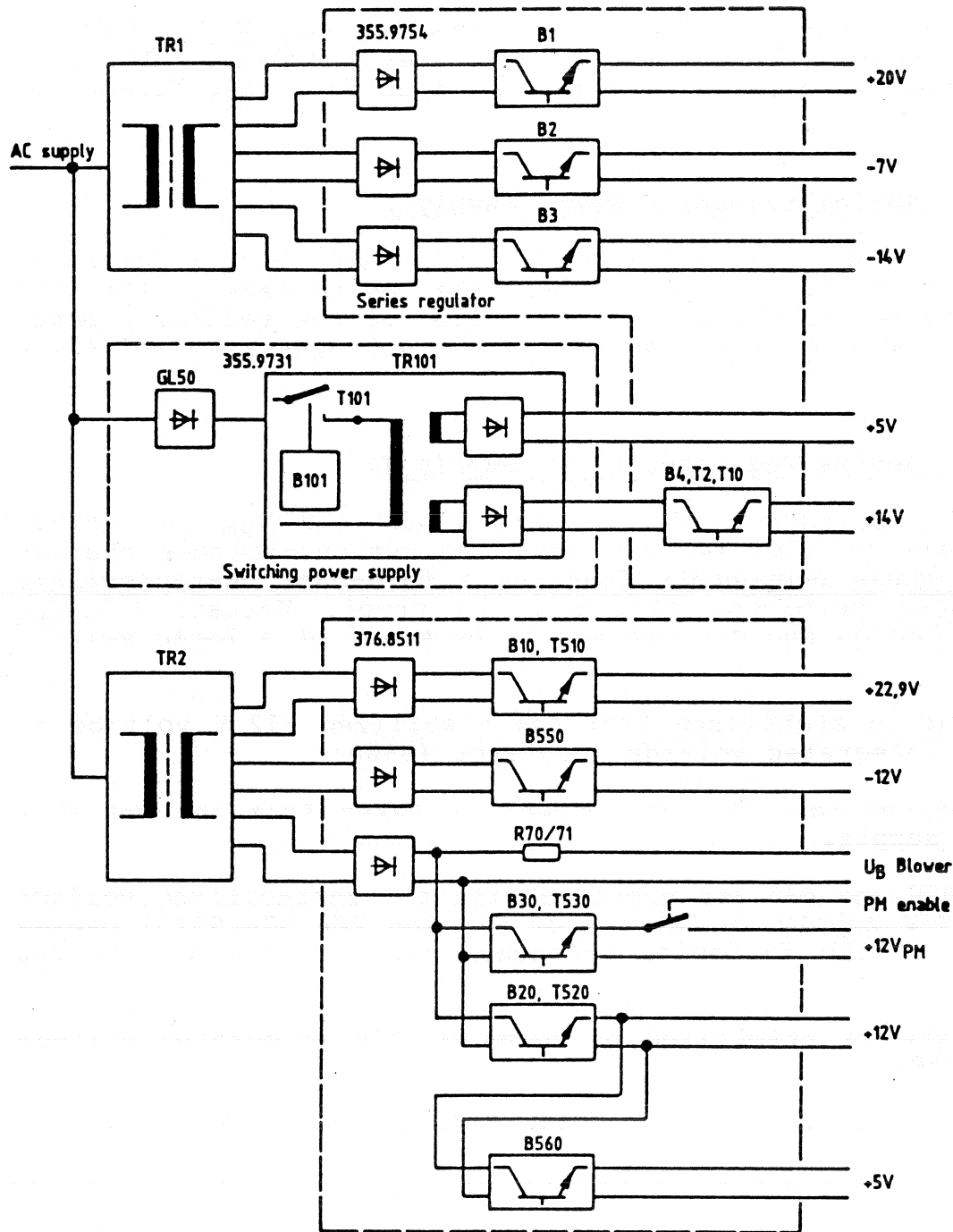

Fig. 5-1 Functional diagram of power supply

### 5.1.1 Switching Power Supply

GL50 rectifies the AC supply and operates as a doubler from 115 to 125 V. The switching transistor T101 is driven from the control chip B101 via the driver transistor T102 and the transformer TR105. The "on" converter supplies two output voltages, 5 V and approximately 16 V. The 5-V output is regulated. The feedback is effected via R116, R115, R114. The overvoltage protection provided at B101/13 switches off the regulator when 6 V approx. is exceeded. Current limiting is accomplished at B101/11 via R133 which acts as a precision resistor and B102. With increasing current single pulses are at first removed and for further increase of current the regulator is switched off, then restarted with a delay until it is switched off again.

The blower is energized from the 5-V winding via GL122. The second output voltage is applied to a series regulator (B4, T10, T2) which stabilizes it at 14 V and frees it from interferences.

### 5.1.2 Series-regulated Power Supply I

The integrated voltage regulators supply the output voltages +20 V (B1), -7 V (B2) and -14 V (B3). The raw voltage of the 20-V supply is applied to the control chip B101 of the switching power supply. Hence when this voltage fails the voltages +5 V and +14 V fail too.

### 5.1.3 Series-regulated Power Supply II

The operating voltages +22.9 V, +12 V and +12 V<sub>PM</sub> are stabilized by means of B10, B20 and B30. The current-voltage characteristic of these components features a fold-back characteristic thus providing permanent short-circuit proof. Voltage +12 V<sub>PM</sub> may be switched on and off via B40 IV by means of a logic switching state.

The +5-V line is stabilized from the stabilized +12 V voltage by means of an integrated voltage regulator (B560).

The operating voltage for the blower is taken from the unstabilized +12-V supply.

Since B10, B20 and B30 are operated with the unstabilized voltage of the +22.9-V supply, a failure of Si1 (on PCB 376.8511) causes the failure of the following voltages: +22.9 V, +12 V, +12 V<sub>PM</sub> and +5 V.

The -12-V line is stabilized by means of the integrated voltage regulator B550.

## 5.2 Checking and Adjustment Procedures

### 5.2.1 Checking the Supply Voltages

The values listed in Table 5-1 must be measured at BU100 (mother-board) and BU500 (controller).

Table 5-1

BU, contact	Voltage	Ripple
100.6	-14 ±0.2 V	<0.35 mV
100.8	-7 ±0.1 V	<0.35 mV
100.10	+5.15 ±0.05 V	<1.4 mV
100.12	+14 ±0.1 V	<0.5 mV
100.14	+20 ±0.1 V	<1 mV
500.1,2	+22.9 ±0.1 V	<0.4 mV
500.3	-12 ±0.2 V	<0.2 mV
500.5,6	+12 ±0.1 V	<0.1 mV
500.7	+5 ±0.2 V	<0.1 mV
500.8	+12 ±0.1 V	<0.2 mV

Test setup for the measurement of ripple

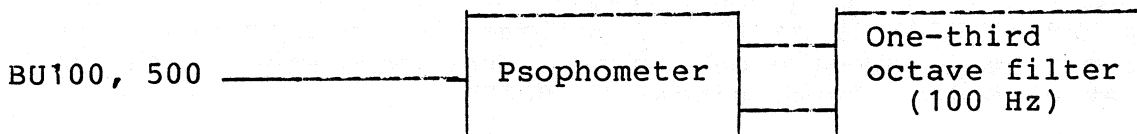

### 5.2.2 Adjustment of the Supply Voltages

Table 5-2

Voltage	Adjust	on PC board	Load current
+20 V	R1	355.9754	0.8 A
+14 V	R18	"	2.7 A
+5 V	R115	355.9731	7.5 A
-7 V	R2	355.9754	0.85 A
-14 V	R5	"	0.7 A
+22.9 V	R17	376.8511	0.4 A
+12 V	R27	"	0.25 A
+12 V <sub>PM</sub> *)	R37	"	0.4 A

\*) In order to switch on the controller for adjusting the voltage +12 V<sub>PM</sub>, contact 4 BU500 must exhibit a voltage of +2 to +5 V. (Link BU500 pin 4 with BU500 pin 7!)

If the power supply I fails or the 20 V it produces, the switching power supply will also fail (supply of B101).



Be very careful when working with the switching power supply. AC supply isolation is obtained at TR105 and TR101. T101 is connected to the AC supply.

If one or several voltages fail in power supply II, check first S1 to S3 on PCB 376.8511. (Failure of S1 causes break down of all voltages but -12 V).

Disconnect the load (BU500) and check, whether a fold-back circuit has responded due to overloading.

### 5.3.1 Switching Power Supply

If T101 fails check the control chip B101 prior to replacing T101 (5.3.1.1). Check GL101, GL103, GL110, GL111, GL112, GL113 and +14-V regulator (B4, T10, T2 on PC board 355.9754) for short-circuits. If no voltage is present at ST3/C,3 - A,1 check R50.

#### 5.3.1.1 Checking the Control Chip B101

Remove SI2. Pull out BU401. Feed DC voltage of 4.5 to 5.5 V into BU401. Connect B101/11 to ground. Switch on SMPD. Watch shape of curve obtained at B101/15 as the DC voltage fed in is varied. The duty cycle of the squarewave must change over from wide (0.45) to narrow at about 5.2 V. Trace signal to BU103.



ROHDE & SCHWARZ  
MÜNCHEN

Schaltteillisten  
Stromläufe  
Bestückungspläne  
Parts lists  
Circuit diagrams  
Components plans

Kennzeichen Component No.	Benennung/Beschreibung Designation	Sachnummer Stock No.	enthalten in contained in
B1	BO UA7915UC -15V1A0 VREGL VOLTAGE REGULATOR FAIRCHILD UA7915UC	BO 282.5432	355.9754
B2	BO UA7906UC - 6V1A0 VREGL VOLTAGE REGULATOR MOTOROLA MC7906CT	BO 355.9783	355.9754
B3	BO LM7912CT -12V1A0 VREGL VOLTAGE REGULATOR NSC LM7912CT	BO 344.9658	355.9754
B4	BO LM124J 4XL.P.OPAMP OPERATIONAL AMPLIFIER NSC LM124J	BO 300.6353	355.9754
B101	BO TDA1060BN8 SCHALTREGLE REGUL.PULSE WIDTH MODUL. VALVO TDA1060BN8	510.6758	355.9731.01
B102	BO LM308AH PREC. OPAMP OPERATIONAL AMPLIFIER MOTOROLA LM308AH	BO 257.4788	355.9731.01
BU2	FM BUCHSENLEISTE 44POL. 44-SOCKET INSERT AMPHENOL 225-22221-410 117	300.6947	355.9719.01
BU3	FM BUCHSENLEISTE 44POL. 44-SOCKET INSERT AMPHENOL 225-22221-410 117	300.6947	355.9719.01
BU4	DX BUCHSENEINHEIT CONNECTOR UNIT	300.9500	300.8427
BU6	DX BUCHSENEINHEIT CONNECTOR UNIT	300.9517	300.8427
BU8	DX BUCHSENEINHEIT CONNECTOR UNIT	300.9523	300.8427
BU10	DX BUCHSENEINHEIT CONNECTOR UNIT	300.9530	300.8427
BU12	DX BUCHSENEINHEIT CONNECTOR UNIT	300.9546	300.8427
BU14	DX BUCHSENEINHEIT CONNECTOR UNIT	300.9552	300.8427
BU16	DX BUCHSENEINHEIT CONNECTOR UNIT	300.9569	300.8427
BU17	DX BUCHSENEINHEIT CONNECTOR UNIT	300.9575	300.8427
BU18	DX BUCHSENEINHEIT CONNECTOR UNIT	356.0696	300.8427
BU20	DX BUCHSENEINHEIT CONNECTOR UNIT	300.8710	
BU21	DX BUCHSENEINHEIT CONNECTOR UNIT	300.8727	
BU22	DX BUCHSENEINHEIT CONNECTOR UNIT	300.8733	
BU30	FP KURZSCHLUSSBUCHSE SHORTING PLUG PK 452-70302	FP 491.7042	355.9754
BU101	FP BUCHSENKONT.EINZELN GS SOCKET CONTACT ROBINSON PS-40-100-G	291.6138	355.9731.01





Kennzeichen Component No.	Benennung/Beschreibung Designation	Sachnummer Stock No.	enthalten in contained in
BU102	FP BUCHSENKONT.EINZELN GS SOCKET CONTACT ROBINSON PS-40-100-G	291.6138	355.9731.01
BU103	FP BUCHSENKONT.EINZELN GS SOCKET CONTACT ROBINSON PS-40-100-G	291.6138	355.9731.01
BU400	DX BUCHSENEINHEIT CONNECTOR UNIT	355.9777	355.9754
BU401	DX BUCHSENEINHEIT CONNECTOR UNIT	300.9581	356.0680
BU402	DX BUCHSENEINHEIT CONNECTOR UNIT	300.9598	356.0680
BU505	DX KABEL CABLE	376.9653	
C1	CK 220NF+-5%63V5RM MKT CAPACITOR WIMA MKS2/63/0,22UF/5%	CK 099.2952	355.9754
C2	CE 47UF-10+50% 40V 9X13 ELECTROLYTIC CAPACITOR ROEDERST EK 00 CB 247 G	CE 006.7142	355.9754
C3	CK 100NF+-5%63V5RM MKT CAPACITOR WIMA MKS/2/63/0,1UF/5%	CK 099.2930	355.9754
C4	CK 220NF+-5%63V5RM MKT CAPACITOR WIMA MKS2/63/0,22UF/5%	CK 099.2952	355.9754
C5	CE 100UF-10+50% 16V 9X13 ELECTROLYTIC CAPACITOR ROEDERST EK 00CB 310 D	CE 006.7165	355.9754
C6	CK 100NF+-5%63V5RM MKT CAPACITOR WIMA MKS/2/63/0,1UF/5%	CK 099.2930	355.9754
C7	CK 220NF+-5%63V5RM MKT CAPACITOR WIMA MKS2/63/0,22UF/5%	CK 099.2952	355.9754
C8	CE 47UF-10+50% 40V 9X13 ELECTROLYTIC CAPACITOR ROEDERST EK 00 CB 247 G	CE 006.7142	355.9754
C9	CK 100NF+-5%63V5RM MKT CAPACITOR WIMA MKS/2/63/0,1UF/5%	CK 099.2930	355.9754
C11	CK 220NF+-5%63V5RM MKT CAPACITOR WIMA MKS2/63/0,22UF/5%	CK 099.2952	355.9754
C12	CE 47UF-10+50% 40V 9X13 ELECTROLYTIC CAPACITOR ROEDERST EK 00 CB 247 G	CE 006.7142	355.9754
C20	CE 10000UF-10+50%40V35X50 ELECTROLYTIC CAPACITOR ROEDERST EYV00CD510G01	300.6401	355.9719.01
C21	CC 10NF-20+50%7X8R6000 CAPACITOR	CC 087.7525	355.9719.01
C22	VALVO 2222 63051 64051103 CE 10000UF-10+50%40V35X50 ELECTROLYTIC CAPACITOR ROEDERST EYV00CD510G01	300.6401	355.9719.01

uns alle Rechte vor



**ROHDE & SCHWARZ**

ÄZ  
16

Datum  
Date  
0586

Schaltteilliste für  
Parts list for  
ZE RUECKEINHEIT  
REAR PANEL

Sachnummer  
Stock No.  
376.8511.01 SA

Blatt  
Page  
3

Kennzeichen Component No.	Benennung/Beschreibung Designation	Sachnummer Stock No.	enthalten in contained in
C23	CC 10NF-20+50%7X8R6000 CAPACITOR VALVO 2222 63051 64051103	CC 087.7525	355.9719.01
C25	CE 10000UF-10+50%16V30X40 ELECTROLYTIC CAPACITOR ROEDERST EYV00BB510D	300.6418	355.9719.01
C26	CC 10NF-20+50%7X8R6000 CAPACITOR VALVO 2222 63051 64051103	CC 087.7525	355.9719.01
C30	CE 470UF-10+50% 40V 15X30 ELECTROLYTIC CAPACITOR ROEDERST ELKO EK470/40	CE 087.0572	355.9719.01
C31	CE 470UF-10+50% 40V 15X30 ELECTROLYTIC CAPACITOR ROEDERST ELKO EK470/40	CE 087.0572	355.9719.01
C32	CE 470UF-10+50% 40V 15X30 ELECTROLYTIC CAPACITOR ROEDERST ELKO EK470/40	CE 087.0572	355.9719.01
C33	CE 220UF-10+50% 40V 15X25 ELECTROLYTIC CAPACITOR ROEDERST ELKO EK220/40	CE 087.0566	355.9719.01
C34	CC 10NF-20+50%7X8R6000 CAPACITOR VALVO 2222 63051 64051103	CC 087.7525	355.9719.01
C40	CE 220UF-10+30%250V30X45 ELECTROLYTIC CAPACITOR VALVO 22 22 052 53221	300.6399	355.9719.01
C41	CE 220UF-10+30%250V30X45 ELECTROLYTIC CAPACITOR VALVO 22 22 052 53221	300.6399	355.9719.01
C42	CS 10NF+-20% 250V RD12X30 ANTI-INTERFERENCE CAPACIT SIEMENS B81121-A-B44	355.9802	355.9719.01
C43	CE 10 UF -10+50%450V18X40 ELECTROLYTIC CAPACITOR SIEMENS B43588-A5106-T	CE 082.3744	355.9719.01
C44	CK 10NF+-20%630V QUADER CAPACITOR ROEDERST MKT1822-310/6	CK 024.7763	355.9719.01
C50	CS 220NF250V10X26,5KL.X2 RADIO-SCREENING CAPACITOR ROEDERST F 1773-422-2000	006.0860	
C51	CK 100NF+-20%100V QUADER PLASTIC-FOIL CAPACITOR ROEDERST MKT1822-410/0	CK 006.5033	
C53	CE 47UF-10+50% 40V 9X13 ELECTROLYTIC CAPACITOR ROEDERST EK 00 CB 247 G	CE 006.7142	355.9719.01
C54	CE 47UF-10+50% 40V 9X13 ELECTROLYTIC CAPACITOR ROEDERST EK 00 CB 247 G	CE 006.7142	355.9719.01
C77	CC 220NF+-10%50V7K1200VIE CERAMIC CAPACITOR UNION CARB CK06BX224K	CC 084.5515	300.5970
C78	CC 1UF+-10%50V7K1200VIEL CAPACITOR UNION CARB CK06BX105K	CC 084.5538	300.5970

376.8511.01 SA BL 3+

Für diese Unterlage behalten wir  
uns alle Rechte vor

**ROHDE & SCHWARZ**

ÄZ	Datum
16	0586

Schaltteilliste für
Parts list for
ZE RUECKEINHEIT
REAR PANEL

Sachnummer
Stock No.
376.8511.01 SA

Blatt
Page
4

uns alle Rechte vor

Kennzeichen Component No.	Benennung/Beschreibung Designation	Sachnummer Stock No.	enthalten in contained in
C79	CC 100NF+-10%50V5K1200VIE CAPACITOR UNION CARB CK05BX104K	CC 084.5350	300.5970
C101	CK 100NF+-20%400V QUADER PLASTIC-FOIL CAPACITOR ERO MKT 1822-410-40-6	CK 006.5256	355.9731.01
C102	CK 100NF+-20%400V QUADER PLASTIC-FOIL CAPACITOR ERO MKT 1822-410-40-6	CK 006.5256	355.9731.01
C103	CC 820PF+-20%1KV8K2000 CERAMIC CAPACITOR VALVO 2212 659 03821	300.6901	355.9731.01
C104	CE 1UF -10+50% 63V 9X13 ELECTROLYTIC CAPACITOR ROEDERST ELKO EK 1/63	CE 022.7620	355.9731.01
C110	CC 10NF-20+50%7X8R6000 CAPACITOR VALVO 2222 63051 64051103	CC 087.7525	355.9731.01
C111	CE 1000UF-10+50%63V 25X45 ELECTROLYTIC CAPACITOR SIEMENS B41306-B8108-T	CE 291.6167	355.9731.01
C112	CC 22NF+-10%50VK1200VIELS CAPACITOR UNION CARB CK05BX223K	CC 060.2445	355.9731.01
C113	CC 10NF-20+50%7X8R6000 CAPACITOR VALVO 2222 63051 64051103	CC 087.7525	355.9731.01
C114	CE 6800UF-10+50%10V36X66 ELECTROLYTIC CAPACITOR THOMSON FELSIC TFRS 6800/10	300.6801	355.9731.01
C115	CC 10NF-20+50%7X8R6000 CAPACITOR VALVO 2222 63051 64051103	CC 087.7525	355.9731.01
C116	CC 220NF+-20% 50V K6000VI CAPACITOR ERIE 8133-50-Z5U-220NF-M	060.1349	355.9731.01
C117	CE 2,2UF-10+50% 63V 9X13 ELECTROLYTIC CAPACITOR ROEDERST ELKO EK 2/63	CE 022.7637	355.9731.01
C118	CC 10NF-20+50%7X8R6000 CAPACITOR VALVO 2222 63051 64051103	CC 087.7525	355.9731.01
C120	CC 2,2NF+-10%5X6R2000 CAPACITOR VALVO 2222 63051 222	CC 087.7060	355.9731.01
C121	CE 47UF-10+50% 40V 9X13 ELECTROLYTIC CAPACITOR ROEDERST EK 00 CB 247 G	CE 006.7142	355.9731.01
C122	CK 150NF+-5%63V5RM MKT CAPACITOR WIMA MKS2/63/0,15UF/5%	CK 099.2946	355.9731.01
C123	CC 22NF+-10%100V7K1200VIE CERAMIC CAPACITOR UNION CARB CK06BX223K	CC 084.5473	355.9731.01
C124	CC 10NF-20+50%7X8R6000 CAPACITOR VALVO 2222 63051 64051103	CC 087.7525	355.9731.01

376.8511.01 SA BL 4+

**RONDE & SCHWARZ**

ÄZ	Datum
16	0586

Schaltteilliste für
Parts list for
ZE RUECKEINHEIT
REAR PANEL

Sachnummer
Stock No.

376.8511.01 SA

Blatt
Page

5

Kennzeichen Component No.	Benennung/Beschreibung Designation	Sachnummer Stock No.	enthalten in contained in
C125	CC 1NF+-10%63V K2000 CERAMIC CAPACITOR VALVO 2222 63051 102	CC 022.0784	355.9731.01
C130	CC 10NF-20+50%7X8R6000 CAPACITOR VALVO 2222 63051 64051103	CC 087.7525	355.9731.01
C131	CE 22UF-10+50% 63V 9X13 ELECTROLYTIC CAPACITOR ROEDERST EK 00 CB 222 J	CE 006.7120	355.9731.01
C132	CC 100NF+-10%50V5K1200VIE CAPACITOR UNION CARB CK05BX104K	CC 084.5350	355.9731.01
C133	CC 1NF+-10%63V K2000 CERAMIC CAPACITOR VALVO 2222 63051 102	CC 022.0784	355.9731.01
C134	CC 4,7NF+-10%6X9R2000 CAPACITOR VALVO 2222 63051 472	CC 087.7102	355.9731.01
D1	ENTHALTEN IN/INCLUDED IN ST1		
D2	LD 5,6MIH 2X2A 200MI OHM CHOKE SIEMENS B 82723-E1-A10	LD 510.6287	300.5970
D3	LD 5,6MIH 2X2A 200MI OHM CHOKE SIEMENS B 82723-E1-A10	LD 510.6287	300.5970
D60	LD 35DB/200M-10GHZ PI-FIL CHOKE ERIE 1214-038	LD 300.6818	300.5970
BIS/TO D75			
GL1	AG KBFO2 140V 2A5 BRGL RECTIFIER GEN-INSTR KBFO2	AG 006.9722	355.9754
GL5	AG KBFO2 140V 2A5 BRGL RECTIFIER GEN-INSTR KBFO2	AG 006.9722	355.9754
GL6	AG KBFO2 140V 2A5 BRGL RECTIFIER GEN-INSTR KBFO2	AG 006.9722	355.9754
GL7	AE BZT03/C30 3.2W Z-DI ZENERDIODE VALVO BZT03/C30	AE 394.8761	355.9754
GL8	AD 1N4448 75V 0,15A UDI DIODE VALVO 1N4448	AD 012.0700	355.9754
GL9	AE BZX55/B5V1 0,5W Z-DI ZENER DIODE VALVO BZX55/B5V1	AE 262.5837	355.9754
GL50	AG B500C3000/1800 BRGL RECTIFIER SIEMENS B500C3000/1800	AG 092.8555	355.9719.01
GL101	AG BYV96E GL1000V 0A8 RECTIFIER VALVO BYV96E	AG 099.9034	355.9731.01

376.8511.01 SA BL 5+

Für diese Unterlage behalten wir  
uns alle Rechte vor

**ROHDE & SCHWARZ**

ÄZ

Datum  
DateSchaltteilliste für  
Parts list for  
ZE RUECKEINHEIT  
REAR PANELSachnummer  
Stock No.Blatt  
Page

16

0586

376.8511.01 SA

6

Kennzeichen Component No.	Benennung/Beschreibung Designation	Sachnummer Stock No.	enthalten in contained in
GL102	AG BYV96E GL1000V 0A8 RECTIFIER VALVO BYV96E	AG 099.9034	355.9731.01
GL103	AG BYV96E GL1000V 0A8 RECTIFIER VALVO BYV96E	AG 099.9034	355.9731.01
GL110	AG BYW29/150 GL 150V 7A0 RECTIFIER VALVO BYW29/150	AG 300.6799	355.9731.01
GL111	AG BYW29/150 GL 150V 7A0 RECTIFIER VALVO BYW29/150	AG 300.6799	355.9731.01
GL112	AG MBR2540 SGL 40V25A0 RECTIFIER MOTOROLA MBR2540 M.ZUBEHOER	AG 086.9930	
GL113	AG MBR2540 SGL 40V25A0 RECTIFIER MOTOROLA MBR2540 M.ZUBEHOER	AG 086.9930	
GL114	AE BZX79/C5V6 0,5W Z-DI ZENER DIODE VALVO BZX79/C5V6	AE 012.2455	355.9731.01
GL119	AE BZX79/C5V6 0,5W Z-DI ZENER DIODE VALVO BZX79/C5V6	AE 012.2455	355.9731.01
GL120	AE BZX79/C15 0,5W Z-DI ZENER DIODE VALVO BZX79/C15	AE 012.2555	355.9731.01
GL122	AG 1N5804 GL 100V 2A5 RECTIFIER UNITRODE 1N5804	AG 453.4762	355.9731.01
K30	DX HF-KABEL RF-CABLE	300.8327	
L30	LD SPEICHERDR.1000UH 2,5A CHOKE VAC ZKB610/051-XX-H2	300.8862	355.9719.01
L50	LD 220UH BEI 0,5A 2,6 OHM CHOKE SIEMENS B 82111-E-C26	LD 099.5200	355.9719.01
L51	LD 220UH BEI 0,5A 2,6 OHM CHOKE SIEMENS B 82111-E-C26	LD 099.5200	355.9719.01
L101	LD 22,0UH10%3,30OHM0,114A CHOKE DELEVAN DROSSEL1025-52	LD 067.3024	355.9731.01
L110	LD SPEICHERDR.630UH/3,15A LOADING COIL VAC R&S-ZCHNG. 356.0667	356.0667	355.9731.01
L111	LD SPEICHERDR.160UH 10A LOADING COIL VAC ZKB 610/049-51-H2	300.6618	355.9731.01
M01	EV 44L/S 12V 4,3W BLOWER PAPST 4112GX	EV 377.0666	

376.8511.01 SA BL 6+

**ROHDE & SCHWARZ**

ÄZ	Datum
16	0586

Schaltteilliste für Parts list for ZE RUECKEINHEIT REAR PANEL
--

Sachnummer Stock No.
-------------------------

376.8511.01 SA

Blatt Page
---------------

7

Kennzeichen Component No.	Benennung/Beschreibung Designation	Sachnummer Stock No.	enthalten in contained in
R1	RS 0,5W500 OHM+-10%10X10X CERMET POTENTIOMETER T BOURNS 3386F-1-501	RS 247.7878	355.9754
R2	RF 0,5 W 680 OHM +-5% DEPOS.-CARBON RESISTOR RESISTA SK4/680OHM5%	RF 007.1354	355.9754
R3	RS 0,5W200 OHM+-10%10X10X CERMET POTENTIOMETER T BOURNS 3386F-1-201	RS 087.7554	355.9754
R4	RF 0,5 W 270 OHM +-5% DEPOS.-CARBON RESISTOR RESISTA SK4/270OHM5%	007.1302	355.9754
R5	RS 0,5W200 OHM+-10%10X10X CERMET POTENTIOMETER T BOURNS 3386F-1-201	RS 087.7554	355.9754
R6	RF 0,5 W 680 OHM +-5% DEPOS.-CARBON RESISTOR RESISTA SK4/680OHM5%	RF 007.1354	355.9754
R8	RL 0,35W 68,1 OHM+-1%TK50 RESISTOR DRALORIC SMA0207/68,1OHM-F-D	RL 082.9636	355.9754
R9	RL 0,35W 475 OHM+-1%TK50 RESISTOR DRALORIC SMA0207/475OHM-F-D	RL 083.0390	355.9754
R10	RF 1,0 W 82 OHM+-5% RESISTOR DRALORIC LCA 0922 820HM+-5%	007.2444	355.9754
R11	RL 0,35W 2,21KOHM+-1%TK50 RESISTOR DRALORIC SMA 0207/2,21K-F-C	RL 082.2477	355.9754
R12	RL 0,35W 2,74KOHM+-1%TK50 RESISTOR DRALORIC SMA0207/2,74K-F-D	RL 083.0926	355.9754
R13	RL 0,35W 12,4KOHM+-1%TK50 RESISTOR DRALORIC SMA 0207/12,4K-F-C	RL 082.6095	355.9754
R14	RL 0,35W 150 KOHM+-1%TK50 RESISTOR DRALORIC SMA/207/150K-F-C	RL 083.2129	355.9754
R15	RL 0,35W 150 OHM+-1%TK50 RESISTOR DRALORIC SMA0207/150OHM-F-D	RL 082.9942	355.9754
R16	RD 2.4 W 0,05 OHM+-3% RESISTOR SAGE 1200S/080200HM/3%	RD 069.1964	355.9754
R17	RL 0,35W 2,21KOHM+-1%TK50 RESISTOR DRALORIC SMA 0207/2,21K-F-C	RL 082.2477	355.9754
R18	RS 0,5W1KOHM+-10%10X10X5 CERMET POTENTIOMETER T BOURNS 3386F-1-102	RS 087.7560	355.9754
R19	RL 0,35W 1KOHM+-1%TK50 RESISTOR DRALORIC SMA0207/1K-F-C	RL 082.2160	355.9754

376.8511.01 SA BL 7+

Für diese Unterlage behalten wir  
uns alle Rechte vor





ROHDE & SCHWARZ

AZ Datum  
Date  
16 0586

Schaltteilliste für  
Parts list for  
ZE RUECKEINHEIT  
REAR PANEL

Sachnummer  
Stock No.  
376.8511.01 SA

Blatt  
Page  
8

uns alle Rechte vor

Kennzeichen Component No.	Benennung/Beschreibung Designation	Sachnummer Stock No.	enthalten in contained in
R20	RL 0,35W 3,32KOHM+-1%TK50 RESISTOR DRALORIC SMA0207/3,32K-F-D	RL 083.0990	355.9754
R50	RD 2.4W 1 OHM +-3% WIRE WOUND RESISTOR SAGE S1200/10HM/3%TK20	RD 069.1441	355.9719.01
R51	RF 0,5 W 82 KOHM+-5% DEPOS.-CARBON RESISTOR RESISTA SK4/82K5%	007.1602	355.9719.01
R52	RF 0,5 W 82 KOHM+-5% DEPOS.-CARBON RESISTOR RESISTA SK4/82K5%	007.1602	355.9719.01
R53	RF 0,5 W 68 OHM+-5% DEPOS.-CARBON RESISTOR RESISTA SK4/68OHM5%	007.1231	355.9719.01
R55	RD 2.4W 10 OHM+-3% WIRE-WOUND RESISTOR SAGE 1200S100HM+3%	RD 087.5097	355.9719.01
R101	RF 0,5 W 33 KOHM+-5% DEPOS.-CARBON RESISTOR RESISTA SK4/33K5%	007.1554	355.9731.01
R102	RD 2.4W 470 OHM+-3% WIRE WOUND RESISTOR SAGE 1200S/470OHM/3%	RD 087.5151	355.9731.01
R103	RD 2.4W 470 OHM+-3% WIRE WOUND RESISTOR SAGE 1200S/470OHM/3%	RD 087.5151	355.9731.01
R104	RD 2.4W 470 OHM+-3% WIRE WOUND RESISTOR SAGE 1200S/470OHM/3%	RD 087.5151	355.9731.01
R105	RL 0,35W 47,5 OHM+-1%TK50 RESISTOR DRALORIC SMA0207/47,5OHM-F-D	RL 082.9507	355.9731.01
R106	RF 0,5 W 20 OHM+-5% DEPOS.-CARBON RESISTOR RESISTA SK4/20OHM5%	028.0128	355.9731.01
R107	RF 0,5 W 33 KOHM+-5% DEPOS.-CARBON RESISTOR RESISTA SK4/33K5%	007.1554	355.9731.01
R108	RF 0,5 W 33 KOHM+-5% DEPOS.-CARBON RESISTOR RESISTA SK4/33K5%	007.1554	355.9731.01
R110	RL 0,35W15 OHM 1%TK50 RESISTOR DRALORIC SMA0207/15OHM-F-D	RL 082.9020	355.9731.01
R111	RL 0,35W 200 OHM+-1%TK50 RESISTOR DRALORIC SMA0207/200OHM-F-D	RL 083.0049	355.9731.01
R113	RL 0,35W 825 OHM+-1%TK50 RESISTOR DRALORIC SMA 0207/825OHM-F-C	RL 082.2502	355.9731.01
R114	RL 0,35W 150 OHM+-1%TK50 RESISTOR DRALORIC SMA0207/150OHM-F-D	RL 082.9942	355.9731.01
R115	RS 0,5W200 OHM+-10%10X10X CERMET POTENTIOMETER BOURNS 3386X-1-201	RS 247.7949	355.9731.01

376.8511.01 SA BL 8+



ROHDE & SCHWARZ

ÄZ Datum  
Date  
16 0586

Schaltteilleiste für  
Parts list for  
ZE RUECKEINHEIT  
REAR PANEL

Sachnummer  
Stock No.

376.8511.01 SA

Blatt  
Page

9

Kennzeichen Component No.	Benennung/Beschreibung Designation	Sachnummer Stock No.	enthalten in contained in
R116	RF 0,25W 4,7 OHM +-5% RESISTOR DRALORIC LCA0207/+5%4,7	074.0033	355.9731.01
R117	RL 0,35W 562 OHM+-1%TK50 RESISTOR DRALORIC SMA0207/5620HM-F-D	RL 083.0461	355.9731.01
R118	RL 0,35W 56,2KOHM+-1%TK50 RESISTOR DRALORIC SMA0207/56,2K-F-C	RL 082.2231	355.9731.01
R119	RL 0,35W 1KOHM+-1%TK50 RESISTOR DRALORIC SMA0207/1K-F-C	RL 082.2160	355.9731.01
R120	RL 0,35W 681 OHM+-1%TK50 RESISTOR DRALORIC SMA0207/6810HM-F-D	RL 083.0490	355.9731.01
R121	RL 0,35W 332 OHM+-1%TK50 RESISTOR DRALORIC SMA0207/3320HM-F-D	RL 083.0255	355.9731.01
R122	RL 0,35W 100KOHM+-1%TK50 RESISTOR DRALORIC SMA0207/100K-F-C	RL 082.1764	355.9731.01
R123	RL 0,35W 681 OHM+-1%TK50 RESISTOR DRALORIC SMA0207/6810HM-F-D	RL 083.0490	355.9731.01
R124	RL 0,35W 1KOHM+-1%TK50 RESISTOR DRALORIC SMA0207/1K-F-C	RL 082.2160	355.9731.01
R125	RL 0,35W 4,75KOHM+-1%TK50 RESISTOR DRALORIC SMA0207/4,75K-F-D	RL 083.1097	355.9731.01
R126	RL 0,35W 2,74KOHM+-1%TK50 RESISTOR DRALORIC SMA0207/2,74K-F-D	RL 083.0926	355.9731.01
R127	RL 0,35W 12,1KOHM+-1%TK50 RESISTOR DRALORIC SMA0207/12,1K-F-D	RL 083.1351	355.9731.01
R128	RL 0,35W 4,75KOHM+-1%TK50 RESISTOR DRALORIC SMA0207/4,75K-F-D	RL 083.1097	355.9731.01
R129	RD 2.4 W 1 KOHM +-3% WIRE WOUND RESISTOR SAGE 1200S/1,0K/3%	RD 067.9297	355.9731.01
R130	RD 2.4 W 1 KOHM +-3% WIRE WOUND RESISTOR SAGE 1200S/1,0K/3%	RD 067.9297	355.9731.01
R131	RL 0,35W 681 OHM+-1%TK50 RESISTOR DRALORIC SMA0207/6810HM-F-D	RL 083.0490	355.9731.01
R132	RL 0,35W 392 OHM+-1%TK50 RESISTOR DRALORIC SMA0207/392K-F-C	RL 082.2183	355.9731.01
R133	RM 0,025 OHM 2,7A WIRE WOUND RESISTOR	300.6082	355.9731.01
R134	RM 0,025 OHM 2,7A WIRE WOUND RESISTOR	300.6082	355.9731.01

376.8511.01 SA BL 9+

Für diese Unterlage behalten wir  
uns alle Rechte vor



ROHDE &amp; SCHWARZ

AZ Datum  
Date  
16 0586Schaltteilliste für  
Parts list for  
ZE RUECKEINHEIT  
REAR PANELSachnummer  
Stock No.  
376.8511.01 SABlatt  
Page  
10

Kennzeichen Component No.	Benennung/Beschreibung Designation	Sachnummer Stock No.	enthalten in contained in
R135	RL 0,35W 56,2KOHM+-1%TK50 RESISTOR DRALORIC SMA0207/56,2K-F-C	RL 082.2231	355.9731.01
R136	RL 0,35W 562 OHM+-1%TK50 RESISTOR DRALORIC SMA0207/562OHM-F-D	RL 083.0461	355.9731.01
R137	RM 0,025 OHM 2,7A WIRE WOUND RESISTOR	300.6082	355.9731.01
R138	RM 0,025 OHM 2,7A WIRE WOUND RESISTOR	300.6082	355.9731.01
R139	RL 0,35W 1,50KOHM+-1%TK50 RESISTOR DRALORIC SMA0207/1,50K-F-D	RL 083.0732	355.9731.01
S1	SB. SCHALT NETZ 2A 0.KNOPF POWER SWITCH PETRICK 285 V (20)1-N 135 E-	SB 020.5495	
S2	SK KIPPSCH.3POL.3A NETZ TOGGLE SWITCH APR R&S-ZCHNG.558.4126	558.4126	
S3	SK KIPPSCH.3POL.3A NETZ TOGGLE SWITCH APR R&S-ZCHNG.558.4126	558.4126	
S4	ST OEFFNER 112 GRD.C THERMAL SWITCH MICROTHERM E21C186T374-T364	355.9790	
SI1	SS SCHMELZ.T1,25 DIN41662 FUSE WICKMANN T1,25 DIN 41662 TROP FUER/FOR 220V/235V ***** SCHMELZS./FUSE T1,6D DIN41571 SS020.7500 FUER/FOR 115V/125V	SS 020.7475	
SI2	SS SCHMELZ.M1,25CDIN41571 FUSE EWGO DIN41571 ....(TROP) FUER/FOR 220V/235V ***** SCHMELZS./FUSE M2,5E DIN41571 SS 020.7569 FUER/FOR 115V/125V	SS 020.7469	
SI3	SS SCHMELZS.TO,8 DIN41662 FUSE WICKMANN TO,8 DIN 41662 TROP	SS 020.7417	355.9754
ST1	FN NETZSTECK.M.FILTER 2A POWERFILTER CONNECTOR SIEMENS B84104-C3-A20	356.1663	
ST2	ENTHALTEN IN/INCLUDED IN LEITERPLATTE/PCB		300.5970
ST3	ENTHALTEN IN/INCLUDED IN LEITERPLATTE/PCB		355.9731.01
ST4	FV FLACHSTECKER 2,8X0,8 CONTACT VOGT 3787/0,8/MS-SN8	FV 517.7608	355.9754

376.8511.01 SA BL10+



ROHDE & SCHWARZ

ÄZ Datum  
Date  
16 0586

Schaltteilliste für  
Parts list for  
ZE RUECKEINHEIT  
REAR PANEL

Sachnummer  
Stock No.

376.8511.01 SA

Blatt  
Page

11

Kennzeichen Component No.	Benennung/Beschreibung Designation	Sachnummer Stock No.	enthalten in contained in
BIS/T0			
ST18			
ST20	FV FLACHSTECKER 2,8X0,8 FLAT PLUG 2,8X0,8	FV 279.1998	355.9719.01
	VOGT 3775A/0,8/MS-S18		
ST21	FV FLACHSTECKER 2,8X0,8 FLAT PLUG 2,8X0,8	FV 279.1998	355.9719.01
	VOGT 3775A/0,8/MS-S18		
ST22	FV FLACHSTECKER 2,8X0,8 FLAT PLUG 2,8X0,8	FV 279.1998	355.9719.01
	VOGT 3775A/0,8/MS-S18		
ST30	FP STIFTLISTE 36POL. PIN CONNECTOR BERG 118-36 2-POLIG/2 PINS	FP 099.3807	355.9754
T2	AK BSX46-16 NPN 60V1000MA TRANSISTOR VALVO BSX46-16	AK 010.6847	355.9754
T10	AL BDX78 PNP 80V 8A0 TRANSISTOR VALVO BDX78	AL 284.4562	355.9754
T101	AL BUX81 NPN 450V 10A0 TRANSISTOR VALVO BUX81	AL 208.2104	300.2029
T102	AL BD139 NPN 80V 1A0 TRANSISTOR VALVO BD139	AL 274.8994	355.9731.01
TR1	ZM TRAFUEINHEIT TRANSFORMER UNIT	300.1322.02	
TR101	LU UEBERTR. 40KHZ NUR VAR : 02 TRANSFORMER VACUUMSCHM ZKB 479/330-XX-W FUER VAR 02/FOF MOD.02 ***** 300.6724	356.0567	355.9731.01
TR105	FUER VAR 03/FOF MOD.03 LU ANSTEUERTRAF0 24V TRANSFORMER 24V AWEH SMPS 2	300.6718	355.9731.01
Y40	ZE 10MHZ-QUARZSZILLATOR 10 MHZ CRYSTAL OSCILLATOR	300.2412	
Y50	ED IEC - PLATTE IEC BOARD	300.5034	
			- ENDE -

376.8511.01 SA BL11-

Für diese Unterlage behalten wir  
uns alle Rechte vor

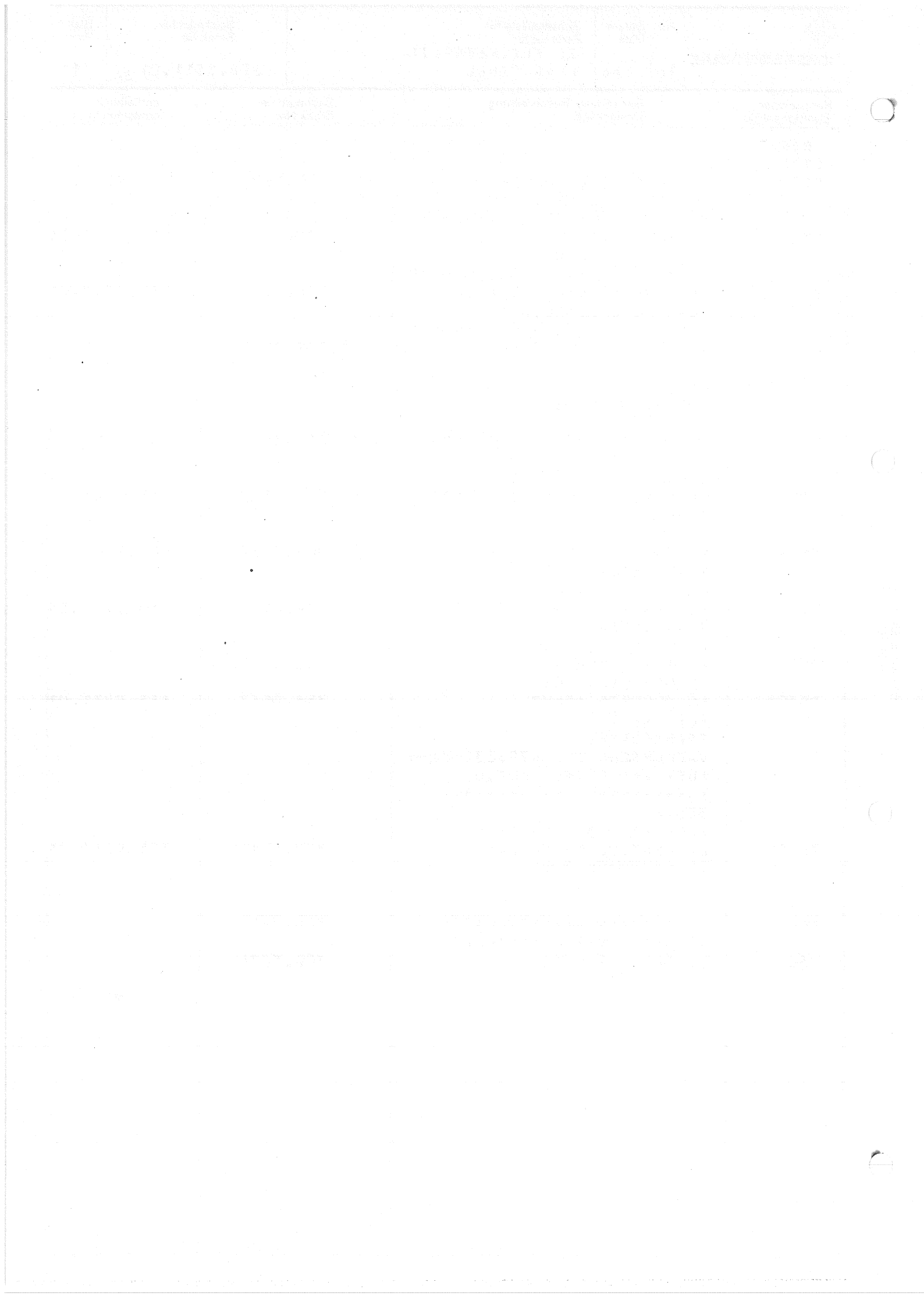



ROHDE & SCHWARZ

ÄZ Datum  
Date

18 0882

Schaltteilliste für  
Parts list for  
ED IEC - PLATTE  
IEC BOARD

Sachnummer  
Stock No.

300.5034

SA

Blatt  
Page

1

Kennzeichen Component No.	Benennung/Beschreibung Designation	Sachnummer Stock No.	enthalten in contained in
BU350	BUCHSE 16/2POL	300.8085	300.8079
BU360	SOCKET INSERT	FM 290.8514	
	FM BUCHSENLEISTE 24POL		
	24-SOCKET INSERT		
	AMPHENOL 57-20240-8		
K350	KABEL 2X16POLIG	300.8079	
K351	RIBBON CABLE		
	ENTHALTEN IN/INCLUDED IN		
	300.8079 (K350)		
S360	SK CODIERSCH MIT HAUBE	SK 240.0126	
	SWITCH		
	AMP	435166-4 MIT 435238-3	
ST352	FP WINKELSTECKERLEIST.36P	FP 243.3578	
	CONNECTOR		
	BERG	75168-113-36	

- ENDE -

Für diese Unterlage behalten wir  
uns alle Rechte vor





ROEDERSTERN

AZ  
Datum  
Date  
06 0485Schaltteilliste für  
Parts list for  
VERDOPPLER NETZTEIL  
DOUBLER SUPPLY BOARDSachnummer  
Stock No.

376.8911.01 SA

Blatt  
Page

1

Kennzeichen Component No.	Benennung/Beschreibung Designation	Sachnummer Stock No.	enthalten in contained in
B550	BO UA7912UC -12V1A0 VREGL VOLTAGE REGULATOR NSC LM7912CT	BO 344.9658	376.8934
B560	BO UA7805UC + 5V1A0 VREGL VOLTAGE REGULATOR FAIRSCHILD UA7805UC	BO 336.4615	376.8934
C501	CE 4700UF-10+50%63V35X80 ELECTROLYTIC CAPACITOR ROEDERST EYV 00CF447J	CE 292.9024	
C502	CE 4,7MF-10+50%40V30X53 ELECTROLYTIC CAPACITOR ROE EYV00BB447G	007.3857	
C503	CE 2200UF-10+50%40V30X50 ELECTROLYTIC CAPACITOR ROEDERST EYV 00BB422G	CE 291.6180	
C504	CE 4,7MF-10+50%40V30X53 ELECTROLYTIC CAPACITOR ROE EYV00BB447G	007.3857	
T510	AL BD235 NPN 60V 2A0 TRANSISTOR VALVO BD235	AL 010.0903	376.8934
T520	AL BD235 NPN 60V 2A0 TRANSISTOR VALVO BD235	AL 010.0903	376.8934
T530	AL BD235 NPN 60V 2A0 TRANSISTOR VALVO BD235	AL 010.0903	376.8934
TR2	LT TRAFÖEINHEIT TRANSFORMER UNIT	377.0514	
Y110	ED REGELTEIL STABILIZER	376.9018.02	
			- ENDE -

Für diese Unterlage behalten wir  
uns alle Rechte vor

376.8911.01 SA BL 1-





ROHDE & SCHWARZ

Äi Datum  
Date  
10 1086

Schaltteilliste für  
Parts list for  
ED REGELTEIL  
STABILIZER

Sachnummer  
Stock No.  
376.9018.01 SA

Blatt  
Page  
2

Kennzeichen Component No.	Benennung/Beschreibung Designation	Sachnummer Stock No.	enthalten in contained in
C60	CK 330NF+-5%63V5RM MKT CAPACITOR WIMA MKS2/63/0,33UF/5%	CK 099.2969	
C61	CK 100NF+-5%63V5RM MKT CAPACITOR WIMA MKS/2/63/0,1UF/5%	CK 099.2930	
C62	CE 10UF -10+50% 63V 9X13 ELECTROLYTIC CAPACITOR ROEDERST ELKOEK10/63	CE 022.7650	
GL1	AG KBF02 140V 2A5 BRGL RECTIFIER	006.9722	
GL2	GEN-INSTR KBF02 AG B40C3700/2200 BRGL RECTIFIER	AG 092.8532	
GL3	SIEMENS B40C3700/2200 AG KBF02 140V 2A5 BRGL RECTIFIER	006.9722	
GL6	GEN-INSTR KBF02 AE BZX79/C30 0,5W Z-DI ZENER DIODE	AE 012.2626	
GL10	VALVO BZX79/C30 AD 1N4448 75V 0,15A UDI DIODE	AD 012.0700	
GL15	VALVO 1N4448 AD BAV21 250V 0,25A UDI DIODE	AD 082.6837	
GL20	INTERMETAL BAV21 AD 1N4448 75V 0,15A UDI DIODE	AD 012.0700	
GL25	VALVO 1N4448 AD BAV21 250V 0,25A UDI DIODE	AD 082.6837	
GL30	INTERMETAL BAV21 AD 1N4448 75V 0,15A UDI DIODE	AD 012.0700	
GL35	VALVO 1N4448 AD BAV21 250V 0,25A UDI DIODE	AD 082.6837	
GL40	INTERMETAL BAV21 AD 1N4448 75V 0,15A UDI DIODE	AD 012.0700	
R9	VALVO 1N4448 RL 0,35W 1KOHM+-1%TK50 RESISTOR	RL 082.2160	
R10	DRALORIC SMA0207/1K-F-C RL 0,35W 10,0KOHM+-1%TK50 RESISTOR	RL 083.1297	
R11	DRALORIC SMA0207/10K-F-D RL 0,35W 1MOHM+-1%TK50 RESISTOR	RL 082.7862	
R12	DRALORIC SMA0207/1M-F-D RD 2.4 W 0,1 OHM+-3% WIRE-WOUND RESISTOR SAGE 1200S/0,10HM/3%	RD 082.0974	

376.9018.01 SA BL 2+

uns alle rechtlich vor

**ROHDE & SCHWARZ**AI Datum  
Date  
10 1086Schaltteilliste für  
Parts list for  
ED REGELTEIL  
STABILIZERSachnummer  
Stock No.  
376.9018.01 SABlatt  
Page  
3

Kennzeichen Component No.	Benennung/Beschreibung Designation	Sachnummer Stock No.	enthalten in contained in
R13	RL 0,35W 100 OHM+-1%TK50 METALFILM-RESISTOR DRALORIC SMA0207/100/HM-F-D	RL 082.6543	
R14	RL 0,35W 100 OHM+-1%TK50 METALFILM-RESISTOR DRALORIC SMA0207/100/HM-F-D	RL 082.6543	
R15	RL 0,35W 39,2KOHM+-1%TK50 RESISTOR DRALORIC SMA/207/39,2K-F-C	RL 083.1745	
R16	RL 0,35W 10,0KOHM+-1%TK50 RESISTOR DRALORIC SMA0207/10K-F-D	RL 083.1297	
R17	RS 0,5W1KOHM+-10%10X10X5 CERMET POTENTIOMETER T BOURNS 3386F-1-102	RS 087.7560	
R18	RL 0,35W 4,32KOHM+-1%TK50 RESISTOR DRALORIC SMA0207/4,32K-F-D	RL 082.6572	
R20	RL 0,35W 10,0KOHM+-1%TK50 RESISTOR DRALORIC SMA0207/10K-F-D	RL 083.1297	
R21	RL 0,35W 562 KOHM+-1%TK50 RESISTOR DRALORIC SMA0207/562K-F-C	RL 083.2664	
R22	RD 2.4 W 0,1 OHM+-3% WIRE-WOUND RESISTOR SAGE 1200S/0,10HM/3%	RD 082.0974	
R23	RL 0,35W 100 OHM+-1%TK50 METALFILM-RESISTOR DRALORIC SMA0207/100/HM-F-D	RL 082.6543	
R24	RL 0,35W 100 OHM+-1%TK50 METALFILM-RESISTOR DRALORIC SMA0207/100/HM-F-D	RL 082.6543	
R25	RL 0,35W 20,0KOHM+-1%TK50 RESISTOR DRALORIC SMA/207/20K-F-C	RL 083.1522	
R26	RL 0,35W 10,0KOHM+-1%TK50 RESISTOR DRALORIC SMA0207/10K-F-D	RL 083.1297	
R27	RS 0,5W2KOHM+-10%10X10X5 CERMET POTENTIOMETER T BOURNS 3386F-1-202	RS 247.7884	
R28	RL 0,35W 15,0KOHM+-1%TK50 RESISTOR DRALORIC SMA0207/15K-F-D	RL 083.1400	
R30	RL 0,35W 10,0KOHM+-1%TK50 RESISTOR DRALORIC SMA0207/10K-F-D	RL 083.1297	
R31	RL 0,35W 562 KOHM+-1%TK50 RESISTOR DRALORIC SMA0207/562K-F-C	RL 083.2664	
R32	RD 2.4 W 0,1 OHM+-3% WIRE-WOUND RESISTOR SAGE 1200S/0,10HM/3%	RD 082.0974	
R33	RL 0,35W 100 OHM+-1%TK50 METALFILM-RESISTOR DRALORIC SMA0207/100/HM-F-D	RL 082.6543	

376.9018.01 SA BL 3+

Für diese Unterlage behalten wir  
uns alle Rechte vor



ROHDE & SCHWARZ

Äl Datum  
Date  
10 1086

Schaltteilliste für  
Parts list for  
ED REGELTEIL  
STABILIZER

Sachnummer  
Stock No.  
376.9018.01 SA

Blatt  
Page  
4

Kennzeichen Component No.	Benennung/Beschreibung Designation	Sachnummer Stock No.	enthalten in contained in
R34	RL 0,35W 100 OHM+-1%TK50 METALFILM-RESISTOR DRALORIC SMA0207/100/HM-F-D	RL 082.6543	
R35	RL 0,35W 20,0KOHM+-1%TK50 RESISTOR DRALORIC SMA/207/20K-F-C	RL 083.1522	
R36	RL 0,35W 10,0KOHM+-1%TK50 RESISTOR DRALORIC SMA0207/10K-F-D	RL 083.1297	
R37	RS 0,5W2KOHM+-10%10X10X5 CERMET POTENTIOMETER T BOURNS 3386F-1-202	RS 247.7884	
R38	RL 0,35W 15,0KOHM+-1%TK50 RESISTOR DRALORIC SMA0207/15K-F-D	RL 083.1400	
R39	RL 0,35W 27,4KOHM+-1%TK50 RESISTOR DRALORIC SMA 0207/27,4K-F-D	RL 082.2583	
R40	RL 0,35W 1,21KOHM+-1%TK50 RESISTOR DRALORIC SMA0207/1,21K-F-D	RL 083.0655	
R54	RL 0,35W 150 OHM+-1%TK50 RESISTOR DRALORIC SMA0207/150OHM-F-D	RL 082.9942	
R70	RD 2.4W 33 OHM+-3% WIRE WOUND RESISTOR SAGE 1200S 3W TK20	RD 087.5122	
R71	RD 2.4W 33 OHM+-3% WIRE WOUND RESISTOR SAGE 1200S 3W TK20	RD 087.5122	
SI1	SS SCHMELZS. M 1C DIN41571 FUSE WICKMANN M1CDIN41571TROP.	SS 020.7430	
SI2	SS SCHMELZS. M2 E DIN41571 FUSE WICKMANN M2EDIN41571TROP.	SS 020.7523	
SI3	SS SCHMELZS. M400CDIN41571 FUSE WICKMANN M0,4CDIN41571TROP	SS 020.7317	
ST9	FV FLACHSTECKER 2,8X0,8 FLAT PLUG 2,8X0,8 VOGT 3775A/0,8/MS-S18	FV 279.1998	
BIS/TO ST14 ST15	FV FLACHSTECKER GR4,8X0,8 PLUG VOGT&CO 3826 MS/0,8 VERZINNT	FV 545.4000	
ST505	FP INDIREKT. STECKERL.36P. PIN CONNECTOR BERG 75160-102-36 2-POLIG	FP 242.3600	

- ENDE -

uns alle Rechte vor





Für diese Zeichnung behalten wir uns alle Rechte vor

**ROHDE & SCHWARZ**

1KGA	gezeichnet	12.83	gu
	bearbeitet	12.83	ls
	geprüft		
	normgepr.		

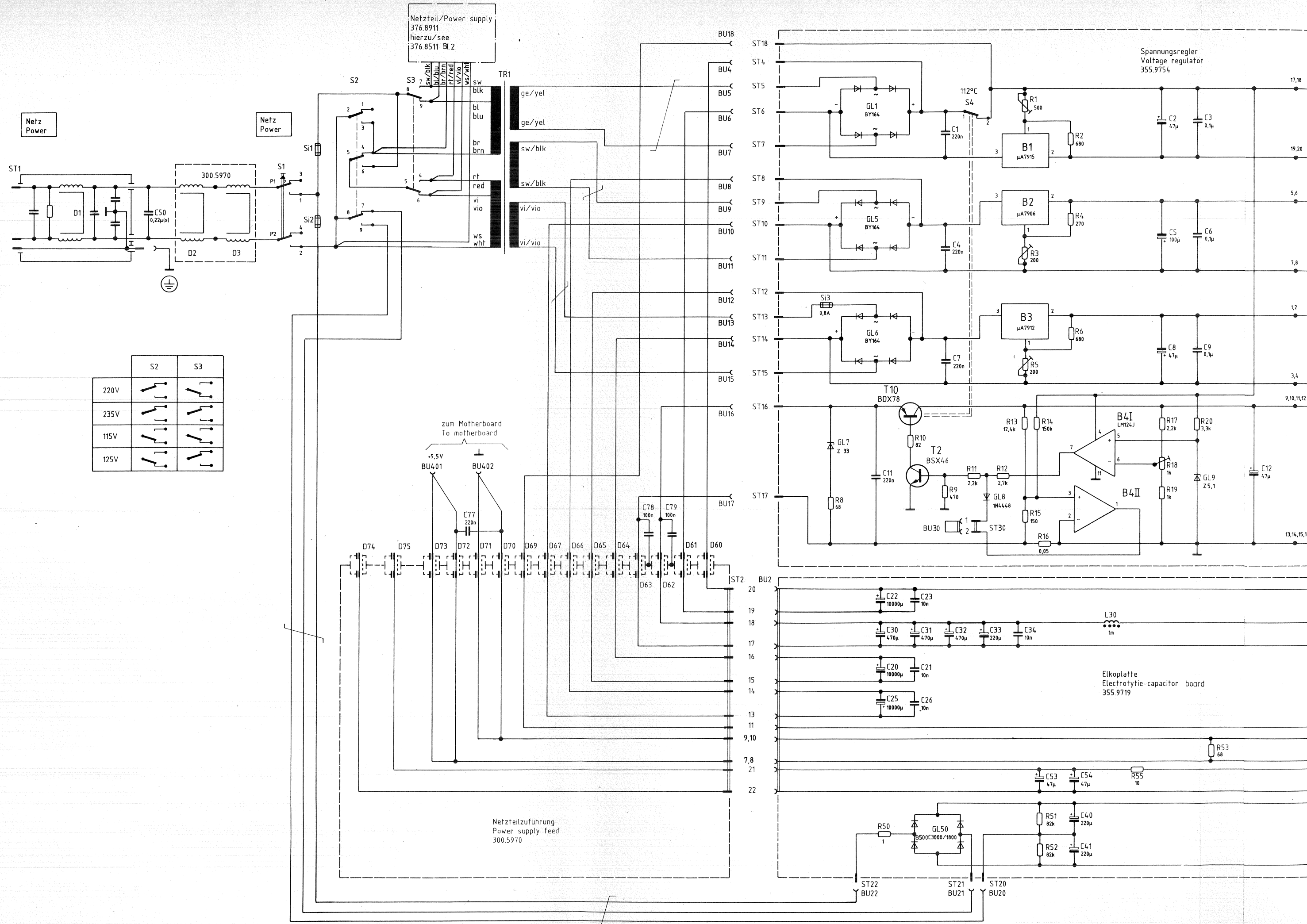

	S2	S3
220V		
235V		
115V		
125V		

Netz Power

Netz Power

Netzteil/Power supply  
376.8911  
hierzu/see  
376.8511 Bl. 2

Spannungsregler  
Voltage regulator  
355.9754

zum Motherboard  
To motherboard

Netzteilzuführung  
Power supply feed  
300.5970

Elkoplatte  
Electrolytic-capacitor board  
355.9719



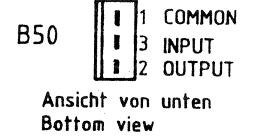
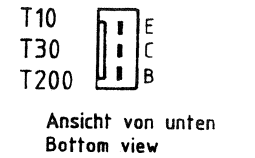
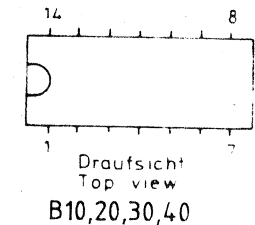
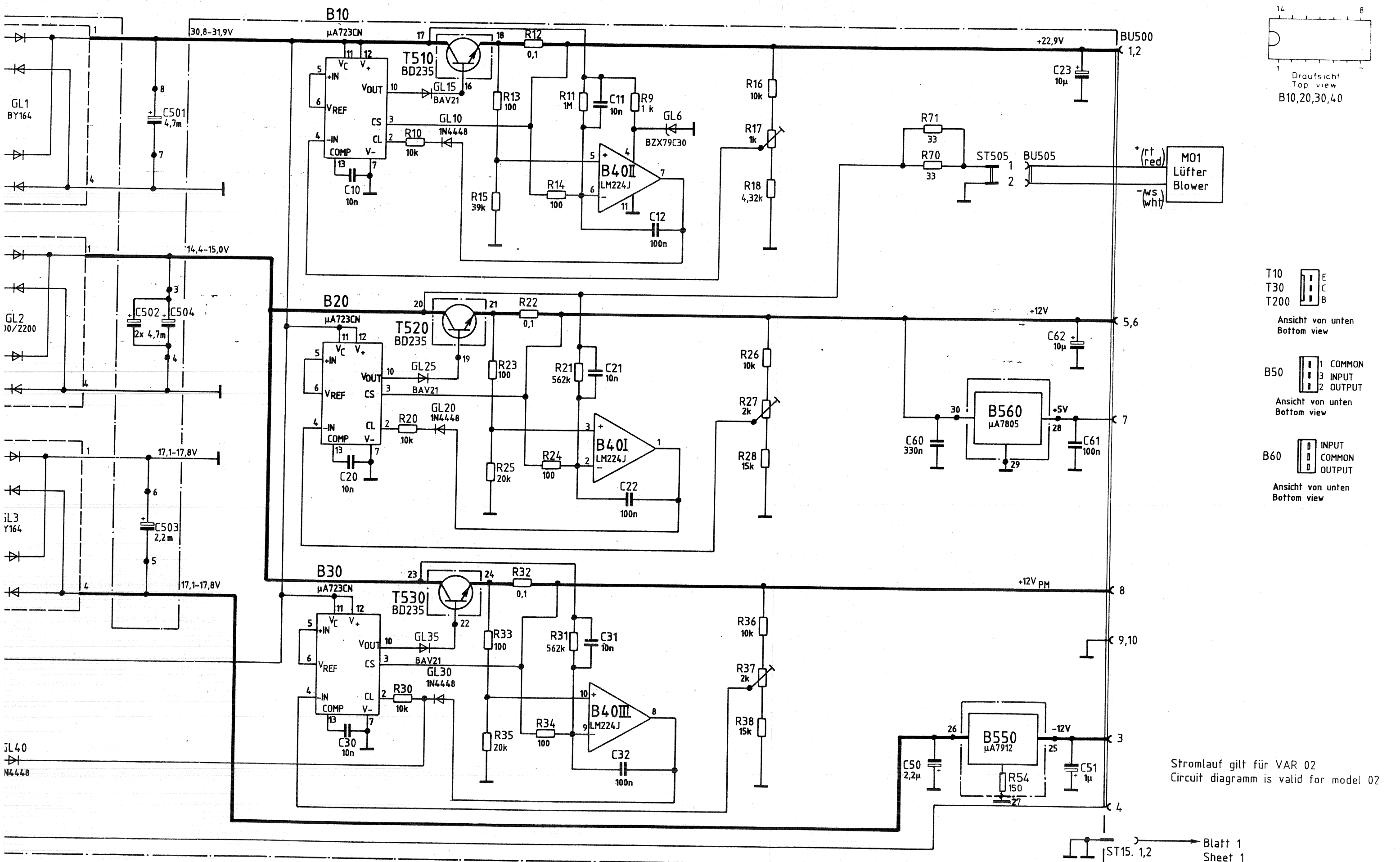

Stromlauf gilt für VAR 02  
Circuit diagram is valid for model 02

Blatt 1  
Sheet 1

	Stromlauf zu		Rückwanne / Rear panel		Z	Zeichn.-Nr.	Blatt-Nr.
	SMPD	reg. i. V.	376.8011 V	erste Z.			

Zeichn.-Nr.	376.8511 S	And. zuz.	A	31459	Datum	5.84	Name	CO
1KGA	gezeichnet	12.83	gu	32946	11.85	GS		
	bearbeitet	12.83	CO					
	geprüft							
	normgepr.							

Für diese Zeichnung behalten wir uns alle Rechte vor.



376.8511 S  
Blatt 2  
Sheet 2

SW	120V	blk
	110V	blu
	0V	brn
	120V	red
	110V	vi
	0V	wh

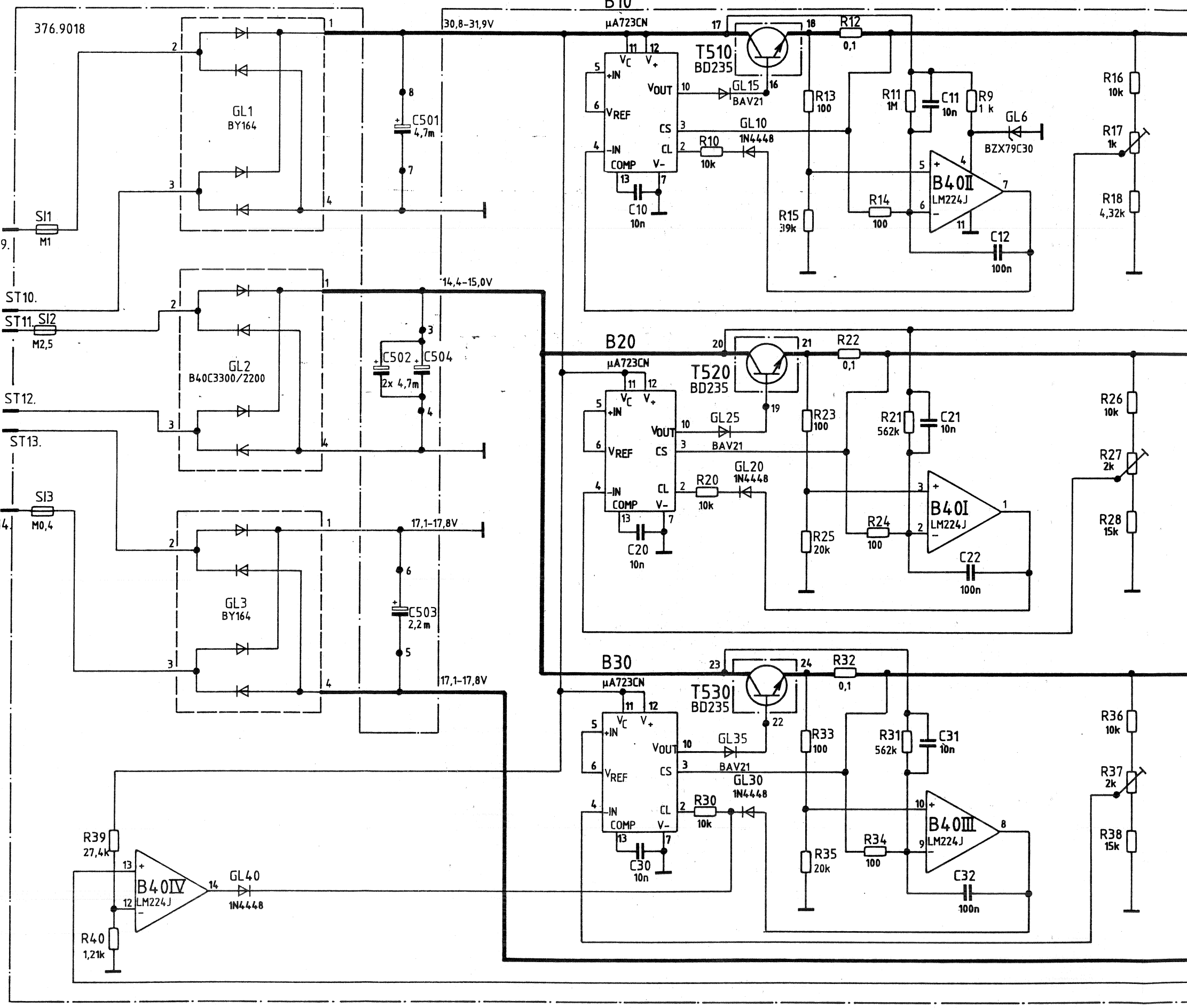







Ansicht und Leitungsführung Bauteilseite  
View of tracks on component side

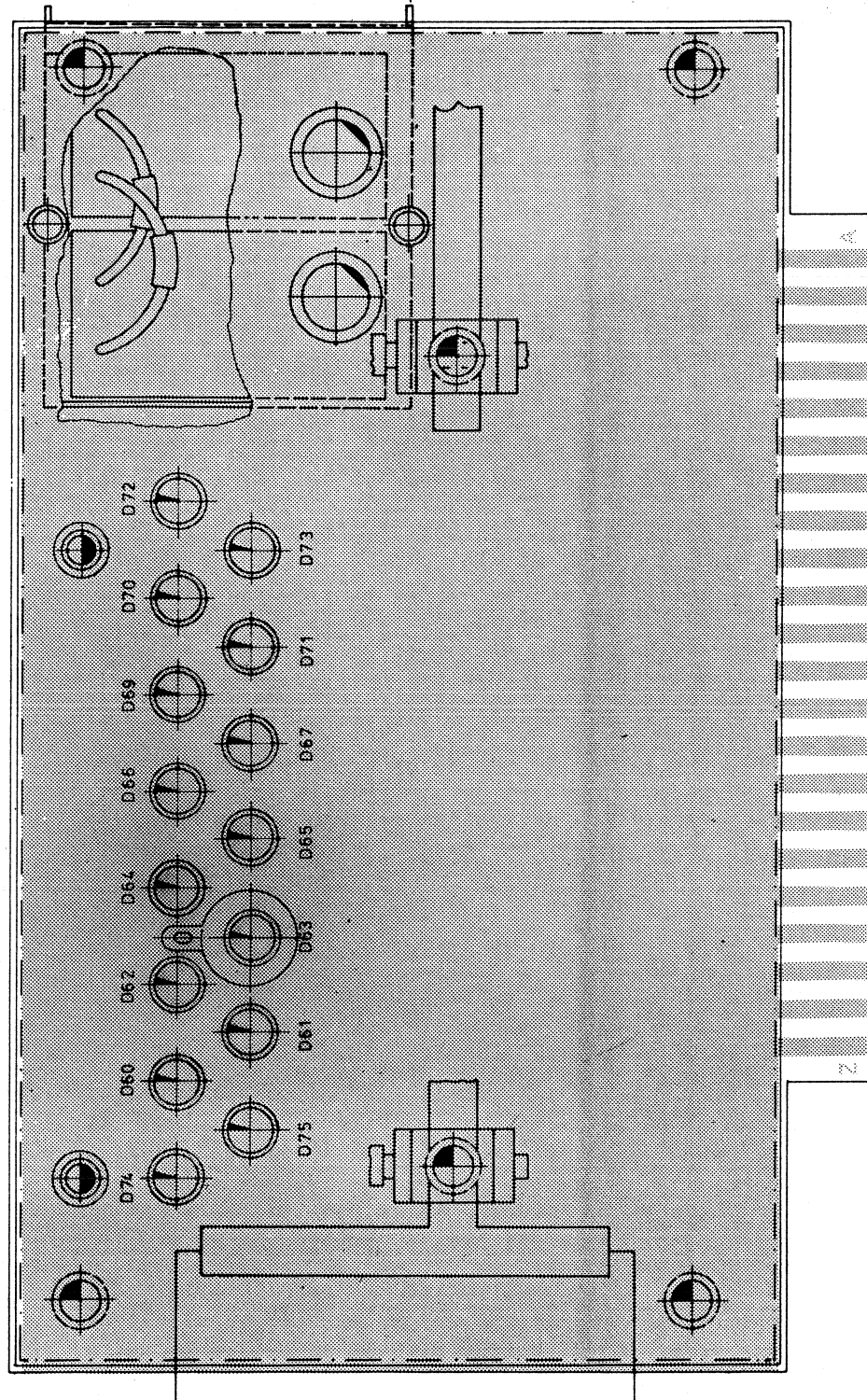

Ansicht und Leitungsführung Lotseite  
View of tracks on solder side

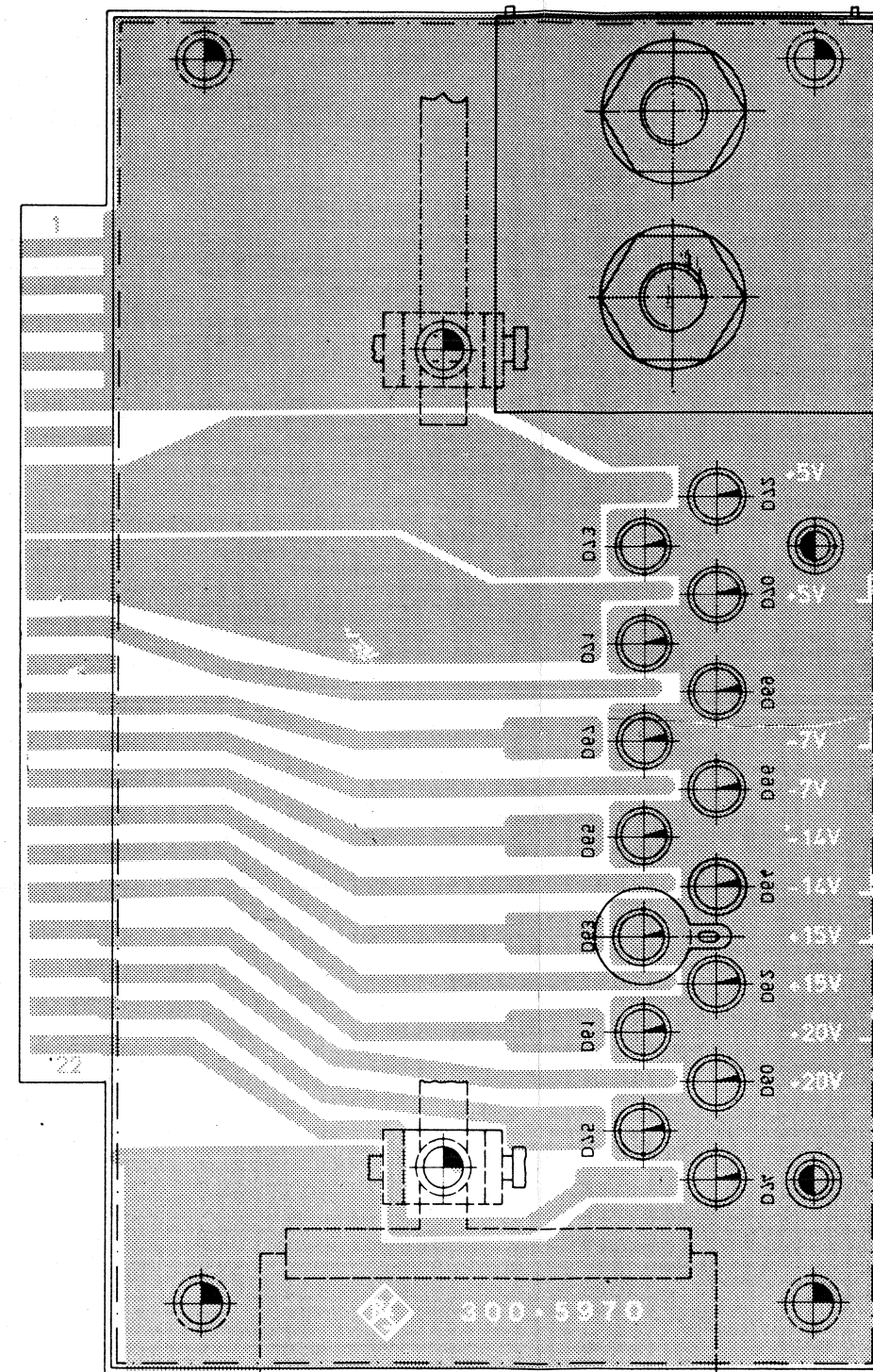

0 1 2 3  
ZENTIMETER

B	18.7.79	LA	2	1
C	5.80	Rs		
F	27.860	LS		
1GMA		LA	Netzteilmzuführung	
2.70		LA	Power-supply feed	
ROHDE & SCHWARZ			300.5970	2
SMPC			300.1000 V	300.2212

Ansicht und Leitungsführung Bauteilseite  
View of tracks on component side

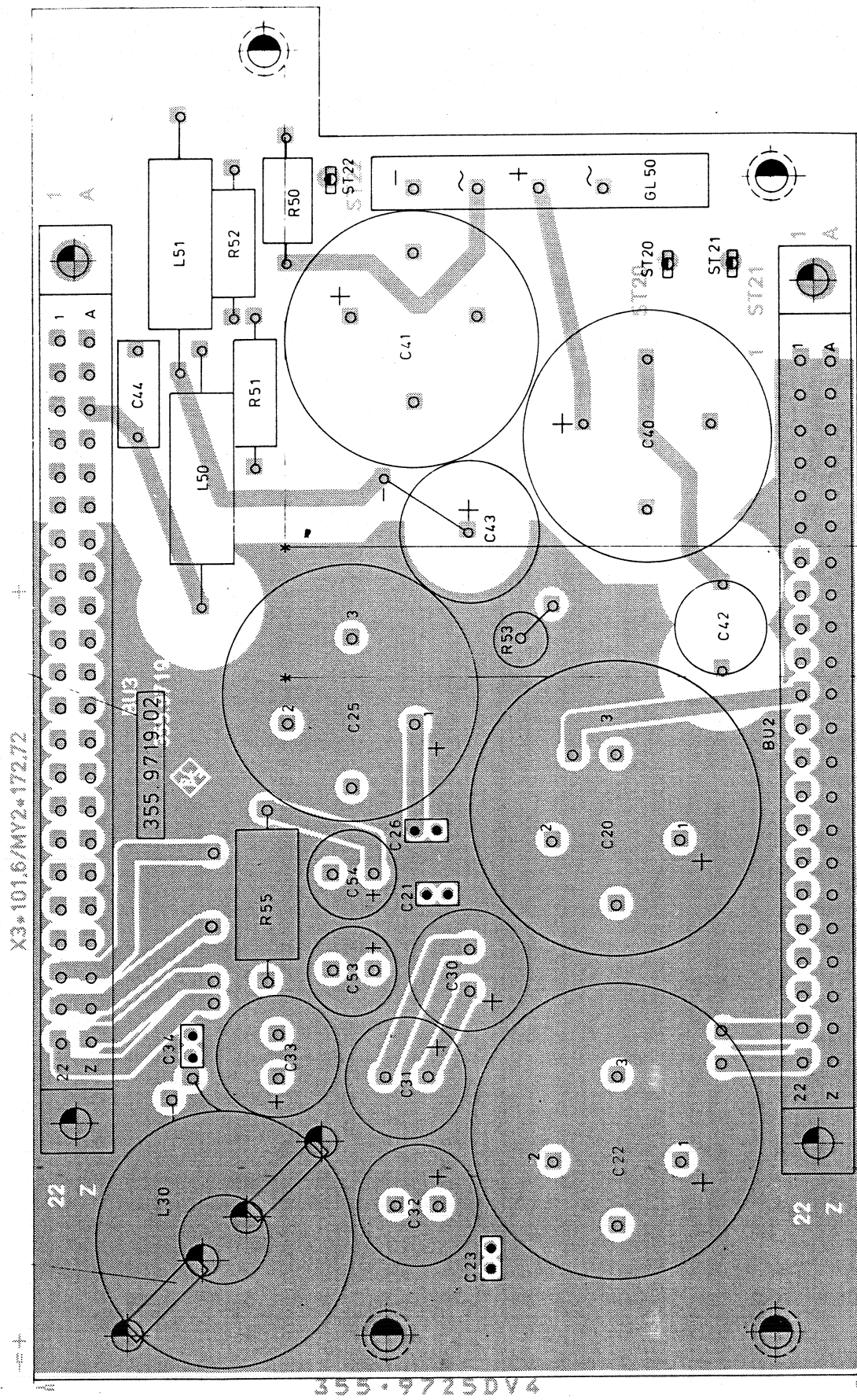

Ansicht und Leitungsführung Lötseite  
View of tracks on solder side

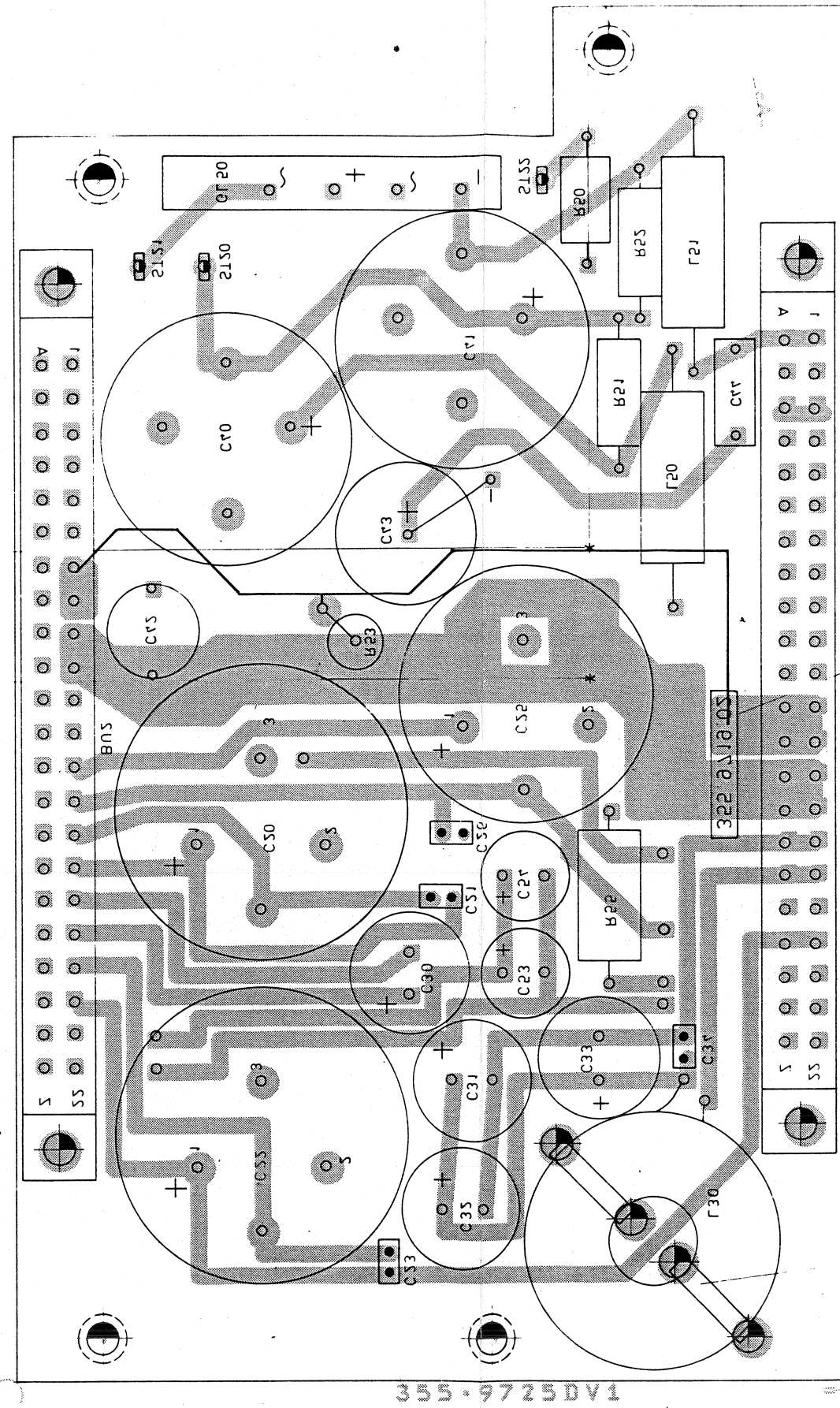

VERKLEINERUNG

C 32288	04.85 LS	Mapung Dateiname	Verf. Nr. 1 : 1
1KGA	04.85 LS	Name	
ROHDE & SCHWARZ		Elkoplatt ELECTROLYTIC-CAPACITOR-BOARD	
SMPC		355.9719	2
		355.9519 V	300.2212







Für diese Zeichnung behalten wir uns alle Rechte vor.

Ansicht und Leitungsführung Bauteilseite  
View of tracks on component side

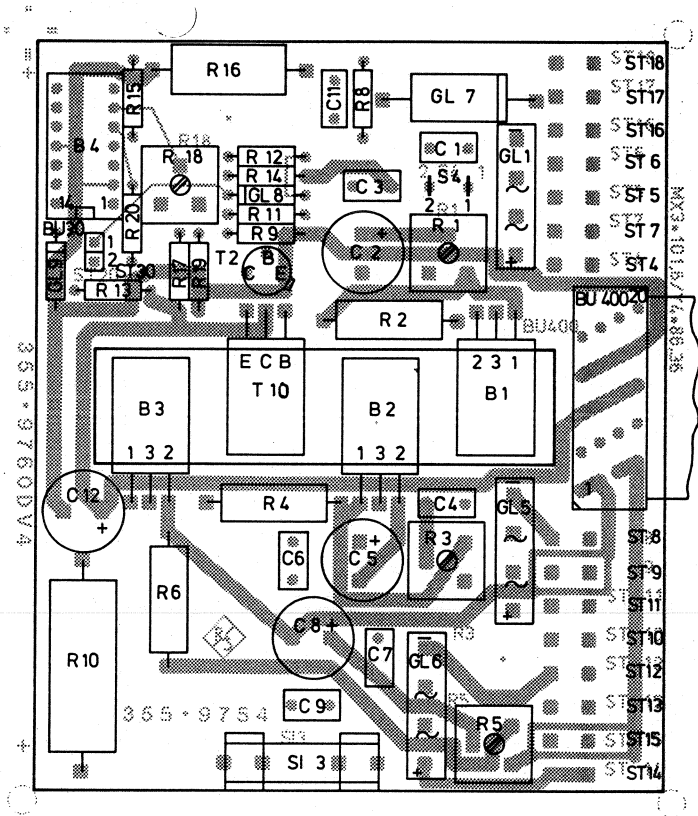

Ansicht und Leitungsführung Lötseite  
View of tracks on solder side

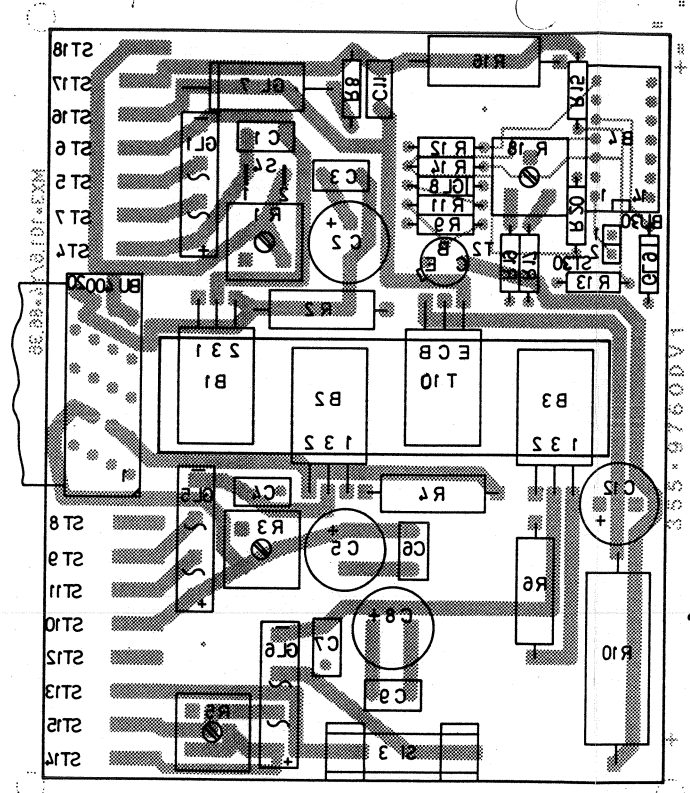

Versorg-Nr				Vg. Sachnr.	
B	27860	5.1.82	LS	Mafie ohne Toleranzangabe	Maßstab 1 : 1
				Halbzeug Werkstoff	
		IGMC	Tag	Name	Benennung
		Bearb.	5.1.82	LS	Spannungsregler
		ROHDE & SCHWARZ			Blatt-Nr.
		355.9754			2
App.	Änderungs-Mitteilung	Tag	Name	z. Behalt. SMPC	355.9519V
				erste	300.2.212

A

B

C

D

E

F

Ansicht und Leitungsführung Bauteilseite  
View of tracks on component side

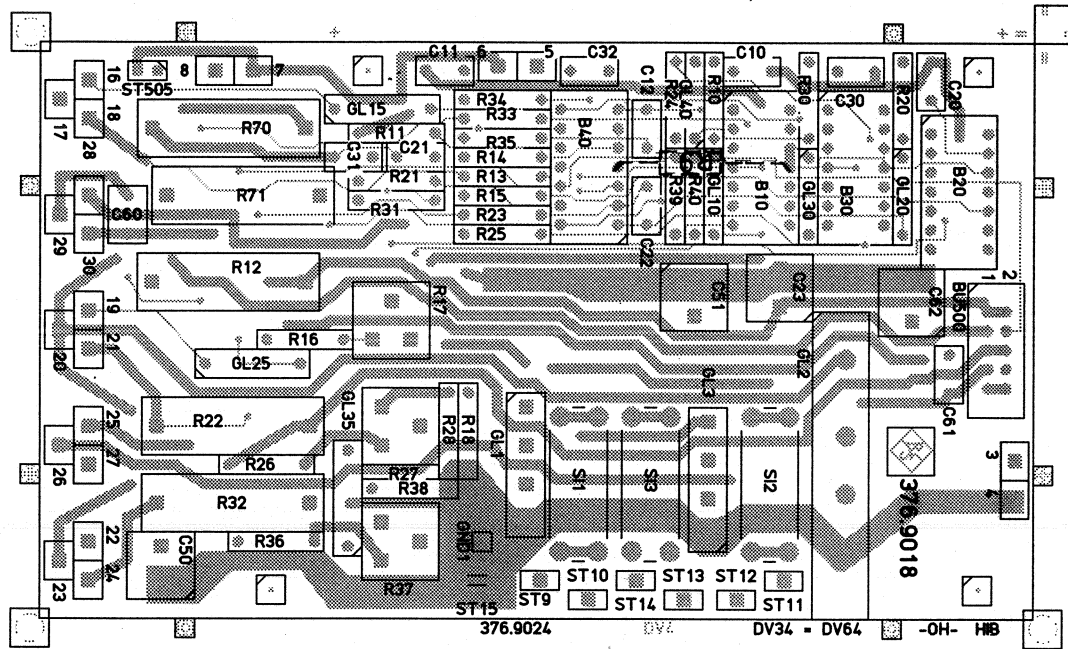

Ansicht und Leitungsführung Lötseite  
View of tracks on solder side

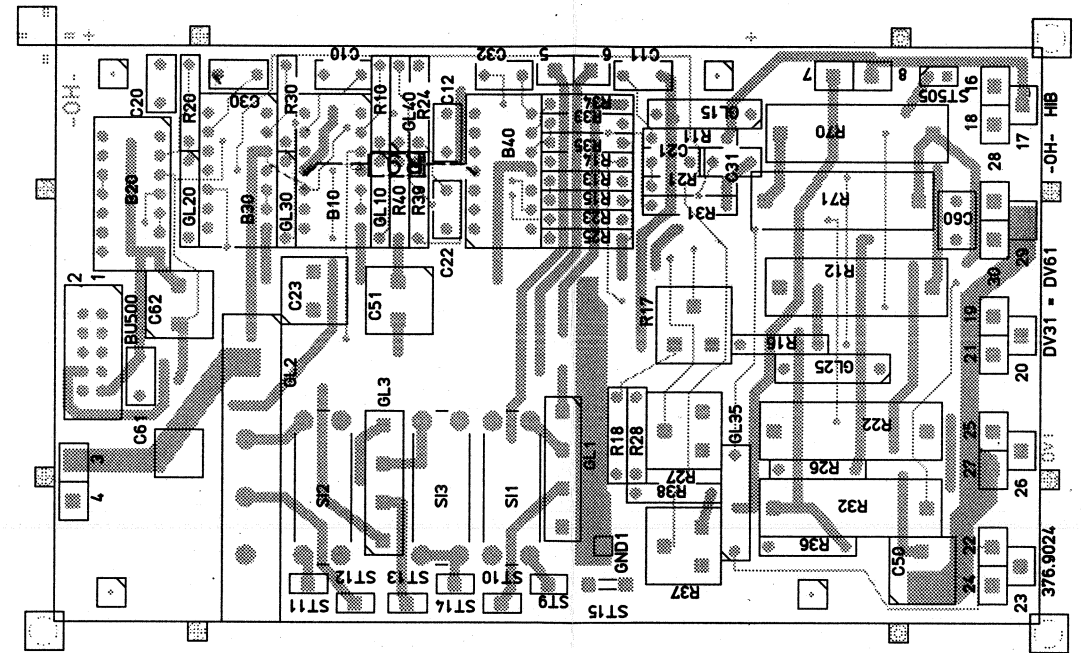

Symbolschlüssel

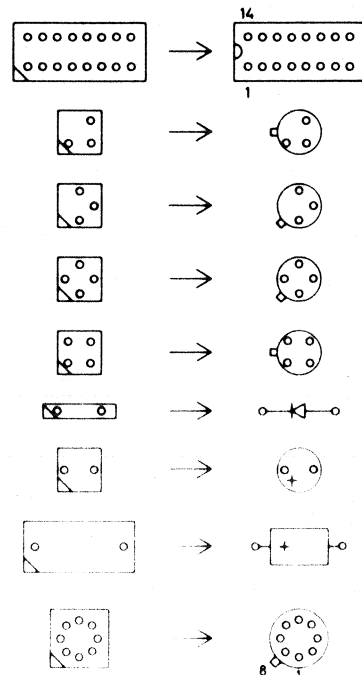

Für diese Unterlage behalten wir uns alle Rechte vor.

ISO Projektion Methode E

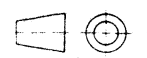

A	31459	3.84	Co	Mafte ohne Toleranzangabe	Maßstab 1 : 1	
					Halbzeug, Werkstoff	
				1KGA Tag Name	Benennung	Z
				Bearb 1.84 CO	Regelteil	
				Gepr	Power supply	
				Norm		
				<b>ROHDE &amp; SCHWARZ</b>	Zeichn.-Nr	Blatt-Nr
				zu Gerät SMPD	376.9018	2
And Zust	Anderungs-Mitteilung	Tag	Name	reg i v 376.8011	erste Z 376.8511	v Bl



**ROHDE & SCHWARZ**

SERVICE INSTRUCTIONS

RF Attenuator

377.0214 (Y30)

Printed in West Germany

# Table of Contents

		Page
<u>5</u>	<u>Service Instructions for RF Attenuator</u>	
	<u>377.0214 (Y30)</u> .....	5.1
5.1	Circuit Description .....	5.1
5.1.1	Attenuator .....	5.1
5.1.2	Driving of the Attenuator .....	5.1
5.2	Checking and Adjustment Procedures .....	5.3
5.2.1	Checking the Attenuator .....	5.3
5.3	Troubleshooting .....	5.4

Parts list  
Circuit diagram  
Components location plans

**Caution!** Do not open the subassembly, since otherwise the guarantee will cease to apply and you will have to carry out a readjustment.

### 5.1 Circuit Description

(See circuit diagram 377.0214 S)

#### 5.1.1 Attenuator

(See circuit diagram 302.7311 S)

The attenuator is connected between the output stage III (Y15) and the output of the SMPD. It permits the signal from Y15 to be attenuated by 140 dB in steps of 2 dB. Narrower level steps - down to 0.1 dB - are electronically adjusted by the amplitude control.

The attenuator is made up of nine pads: 1 x 1 dB, 1 x 2 dB, 2 x 4 dB, 1 x 10 dB, 2 x 20 dB and 2 x 40 dB (R1 to R9) and ten through-lines. The thin-film attenuator pads and through-lines are mounted on small ceramic plates which in turn are soldered on a common base plate. Among them nine contact groups protrude from the base plate with three switching contacts each which permit switching over between attenuation and through-connection.

Each of these nine contact groups is actuated by a rocker which is driven from a magnetic coil and kept in its final position by a permanent magnet. The transmission of force between rocker and contact is accomplished by means of springs which ensure a uniform contact force of 20 p. All contact surfaces are gold-plated.

The magnetic coils for attenuation switchover are driven via power gates B1 to B5. The 1-dB attenuator pad is used for switching off the output of the SMPD. For this purpose the last contact is omitted in the 1-dB attenuator pad. Hence, when this attenuator pad is switched on the signal path is interrupted.

#### 5.1.2 Driving of the Attenuator

(See circuit diagram 377.0214 S)

The power supply for the attenuator is switched on with a delay via the relay RS1. The comparator output B4 II switches on T1 and as a result RS1 only when the +5-V voltage at the non-inverting input exceeds the reference voltage at the inverting input (time constant: R14-C7). During this delay the reset process takes place in the microprocessor. In this way, undefined states of the attenuator are prevented.

Since the attenuation of the attenuator is undefined after switch-on each attenuator pad R1 to R8 is now driven twice upon initialization (output data bus: 10101010 and 01010101). Subsequently the attenuator setting stored after the SMPD has been switched off last is output.

The attenuator is set by transmitting the setting code via the data bus D<sub>0</sub> to D<sub>7</sub>. Strobe 1 writes these data into the memory B1. The attenuator setting is retained until strobe 1 writes new data into the memory. Strobe 2 controls the RF OFF switch of the attenuator. D<sub>0</sub> delivers the required information (LSB of data bus): 1 = RF OFF, 0 = RF ON. This state is stored in B5.

The Overload Protection Option SMPD-B2 has access to the RF OFF switch of the attenuator. If the voltage supplied by the Option exceeds the reference voltage adjustable with R11, the comparator B6 switches and the voltage applied to transistor T4 (approx. +5 V) causes the RF OFF switch via B3 and B2 to assume the off state. The information that the Overload Protection has responded is sent from output B2 II via BU300, pin 13 to the microprocessor which softwarewise (D<sub>0</sub> = 1 and strobe 2) releases the RF OFF switch. By pressing the LEV MIN key the switch can again be enabled. The monoflop B3 keeps the switch open until the processor responds.

When the SMPD is switched off the +5-V voltage at the comparator B4 II rolls off faster than the reference voltage. As a result, RS1 immediately switches off the supply voltage for the attenuator. By switching off the +14-V voltage a short positive pulse is produced in the gates B1 to B5 which switches on all attenuator pads so that the attenuator setting is at maximum when the SMPD is switched off.



## 5.2 Checking and Adjustment Procedures

### 5.2.1 Checking the Attenuator

Connect precision attenuator with test receiver and frequency controller to the RF output of the SMPD. Make sure that the connecting cables are leakage-proof.

Test setup

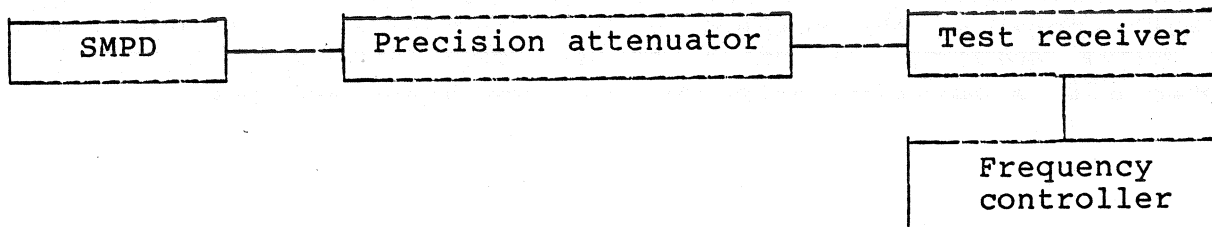

Settings:

Precision attenuator: 120 dB attenuation  
SMPD: 500 MHz, 13 dBm, RCL 07  
Test receiver: 500 MHz, -10 dB, linear, average value  
bandwidth 15 kHz  
Frequency controller: DFC mode

Check:

Note the level indicated on the test receiver as reference value (approximately 0 dB $\mu$ V). Repeat measurement at the settings listed in Table 5-1.

Table 5-1

Level SMPD dBm	Attenuation of precision attenuator dB
11	118
9	116
5	112
3	110
-7	100
-27	80
-47	60
-67	40
-87	20
-107	0

The deviation from the reference value must not exceed 1.2 dB.

### 5.3 Troubleshooting

(For signature analysis see CPU (Y1))

In the case of faulty attenuation check the control lines. To this end, the attenuator must be made accessible (remove front panel and RF cable to the attenuator, unscrew attenuator and place beside the SMPD).

Check the control lines at B1 and BU10 (logic high corresponds to attenuator pad cut in) at the attenuator settings according to Table 5-2.

When the attenuator pad is cut in, negative pulses from 12 V to 13 V must appear at the respective coil terminals RS1 to RS9. The total pulse duration is about 20 ms. When the attenuation is switched off, a positive pulse of the same shape appears.

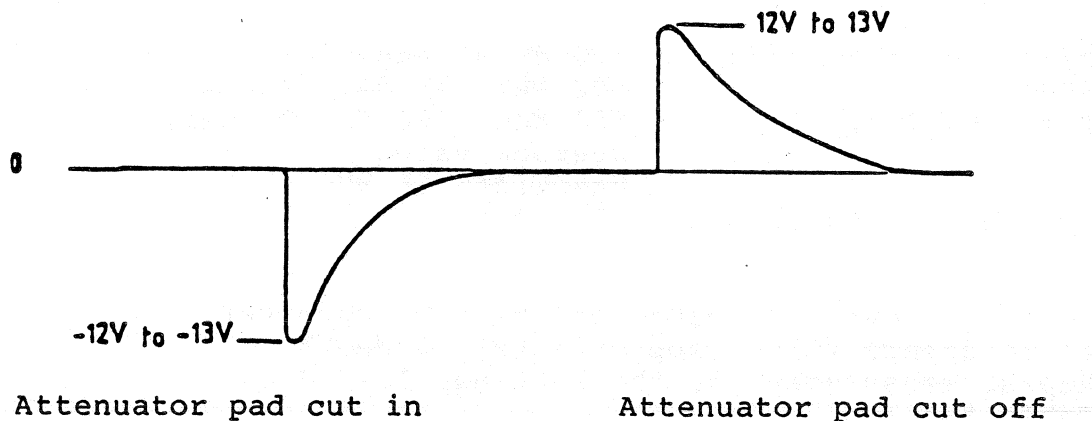

Setting on the SMPD: RCL 07

Table 5-2

Level setting SMPD (dBm)	+11	+9	+5	+3	-7	-27	-67	-87	RF OFF
Attenuator setting/dB	2	4	8	10	20	40	80	100	
Control line BU10 ("H")	2	4	3,4	5	6	8	7,8	6,7,8	1
Coil (RS)	7	1	6,1	3	4	2	2,5	4,2,5	9

If the correct attenuation is not obtained in spite of all windings being correctly driven, the trouble source is the RF section of Y30. In this case contact your nearest R&S representative.

**Note:**

Never unscrew the base plate of the attenuator as this would require new adjusting of the Y30.



ROHDE & SCHWARZ  
MÜNCHEN

Schalteillisten  
Stromläufe  
Bestückungspläne  
Parts lists  
Circuit diagrams  
Components plans



ROHDE & SCHWARZ

ÄZ Datum  
Date  
07 0586

Schalteilleiste für  
Parts list for  
ZE HF-EICHLITUNG  
ATTENUATION SET

Sachnummer  
Stock No.  
377.0214.00 SA

Blatt  
Page  
1

Kennzeichen Component No.	Benennung/Beschreibung Designation	Sachnummer Stock No.	enthalten in contained in
B1	BL SN74LS273N 8BIT-D-REG. 8BIT-D-REGISTER TEXAS SN74LS273N	214.8998	377.0220.01
B2	BL SN74LS02N 4/2INP.NOR IC NOR GATE SN74LS02N TEXAS SN74LS020N	266.4658	377.0220.01
B3	BL SN74121N -0+70MONOFLOP IC MONOSTABLE MULTIVIBRAT TEXAS SN74121N	009.3202	377.0220.01
B4	BO CA3240AE 2XMOS OPAMP OPERATIONAL AMPLIFIER RCA CA3240AE	BO 302.7040	377.0220.01
B5	BL SN74LS74AN 2/D-FLIPFL. IC FLIP-FLOP SN74LS74N TEXAS SN74LS74N	266.7934	377.0220.01
B6	BO LF353H 2XFET OPAMP OPERATIONAL AMPLIFIER NSC LF353H	218.3426	377.0220.01
BU300	FR JC-FASSUNG 16 POLIG 16-PIN IC-SOCKET PRECICONT US016T	FR 249.6091	377.0220.01
C1	CE 10UF+-20%35V 5RDX5 ELEKTROLYTIC CAPACITOR NATION PAN ECE-A1VKS-100	803.0667	377.0220.01
C2	CE 470NF+-20%35V 5X 4X 7 ELECTROLYTIC CAPACITOR ERO-TANTAL TA-ELKOETR1-0,47/35	CE 022.8179	377.0220.01
C3	CE 10UF+-20%35V 5RDX5 ELEKTROLYTIC CAPACITOR NATION PAN ECE-A1VKS-100	803.0667	377.0220.01
C4	CC 10NF-20+50%7X8R6000 CAPACITOR VALVO 2222 63051 64051103	CC 087.7525	377.0220.01
C5	CE 10UF+-20%35V 5RDX5 ELEKTROLYTIC CAPACITOR NATION PAN ECE-A1VKS-100	803.0667	377.0220.01
C6	CC 10NF-20+50%7X8R6000 CAPACITOR VALVO 2222 63051 64051103	CC 087.7525	377.0220.01
C7	CC 10NF-20+50%7X8R6000 CAPACITOR VALVO 2222 63051 64051103	CC 087.7525	377.0220.01
C9	CE 10UF+-20%35V 5RDX5 ELEKTROLYTIC CAPACITOR NATION PAN ECE-A1VKS-100	803.0667	377.0220.01
C10	CE 10UF+-20%35V 5RDX5 ELEKTROLYTIC CAPACITOR NATION PAN ECE-A1VKS-100	803.0667	377.0220.01
C11	CE 47UF+-20%10V6,3RDX5RAD ELECTROLYTIC CAPACITOR NATIONAL ECEA1AKS470	377.0308	377.0220.01
GL1	AD 1N4448 75V 0,15A UDI DIODE VALVO 1N4448	AD 012.0700	377.0220.01

377.0214.00 SA BL 1+

Für diese Unterlage behalten wir  
uns alle Rechte vor

**ROHDE & SCHWARZ**

ÄZ	Datum
07	0586

Schaltteilliste für
Parts list for
ZE HF-EICHLITUNG
ATTENUATION SET

Sachnummer
Stock No.

377.0214.00 SA

Blatt
Page

2

Kennzeichen Component No.	Benennung/Beschreibung Designation	Sachnummer Stock No.	enthalten in contained in
GL2	AD 1N4448 75V 0,15A UDI DIODE VALVO 1N4448	AD 012.0700	377.0220.01
GL3	AD 1N4448 75V 0,15A UDI DIODE VALVO 1N4448	AD 012.0700	377.0220.01
GL4	AE BZX79/C5V6 0,5W Z-DI ZENER DIODE VALVO BZX79/C5V6	AE 012.2455	377.0220.01
GL5	AE BZX79/C5V6 0,5W Z-DI ZENER DIODE VALVO BZX79/C5V6	AE 012.2455	377.0220.01
GL6	AD 1N4448 75V 0,15A UDI DIODE VALVO 1N4448	AD 012.0700	377.0220.01
GL7	AD 1N4448 75V 0,15A UDI DIODE VALVO 1N4448	AD 012.0700	377.0220.01
GL8	AD 1N4448 75V 0,15A UDI DIODE VALVO 1N4448	AD 012.0700	377.0220.01
GL9	AD 1N4448 75V 0,15A UDI DIODE VALVO 1N4448	AD 012.0700	377.0220.01
GL10	AE BZX55/B5V1 0,5W Z-DI ZENER DIODE VALVO BZX55/B5V1	AE 262.5837	377.0220.01
K301	DX FLACHBANDKABEL RIBBON-CABLE	300.8027	377.0220.01
R1	RL 0,35W 22,1KOHM+-1%TK50 RESISTOR DRALORIC SMA/207/22,1K-F-C	RL 083.1545	377.0220.01
R2	RL 0,35W 4,75KOHM+-1%TK50 RESISTOR DRALORIC SMA0207/4,75K-F-D	RL 083.1097	377.0220.01
R3	RL 0,35W 12,1KOHM+-1%TK50 RESISTOR DRALORIC SMA0207/12,1K-F-D	RL 083.1351	377.0220.01
R4	RL 0,35W 4,75KOHM+-1%TK50 RESISTOR DRALORIC SMA0207/4,75K-F-D	RL 083.1097	377.0220.01
R5	RL 0,35W 1KOHM+-1%TK50 RESISTOR DRALORIC SMA0207/1K-F-C	RL 082.2160	377.0220.01
R6	RL 0,35W 4,75KOHM+-1%TK50 RESISTOR DRALORIC SMA0207/4,75K-F-D	RL 083.1097	377.0220.01
R7	RL 0,35W 4,75KOHM+-1%TK50 RESISTOR DRALORIC SMA0207/4,75K-F-D	RL 083.1097	377.0220.01
R8	RL 0,35W 2,74KOHM+-1%TK50 RESISTOR DRALORIC SMA0207/2,74K-F-D	RL 083.0926	377.0220.01

377.0214.00 SA BL 2+





ROHDE & SCHWARZ

ÄZ Datum  
Date  
07 0586

Schaltteilliste für  
Parts list for  
ZE HF-EICHLITUNG  
ATTENUATION SET

Sachnummer  
Stock No.  
377.0214.00 SA

Blatt  
Page  
3

Kennzeichen Component No.	Benennung/Beschreibung Designation	Sachnummer Stock No.	enthalten in contained in
R9	RL 0,35W 4,75KOHM+-1%TK50 RESISTOR DRALORIC SMA0207/4,75K-F-D	RL 083.1097	377.0220.01
R10	RL 0,35W 27,4KOHM+-1%TK50 RESISTOR DRALORIC SMA 0207/27,4K-F-C	RL 082.2583	377.0220.01
R11	RS 0,5W 1KOHM+-20%KURVE1 DEPOS.-CARBON POTENTIOMET BOURNS 3329H-1-102	RS 069.8030	377.0220.01
R12	RL 0,35W 1MOHM+-1%TK50 RESISTOR DRALORIC SMA0207/1M-F-D	RL 082.7862	377.0220.01
R13	RL 0,35W 10,0KOHM+-1%TK50 RESISTOR DRALORIC SMA0207/10K-F-D	RL 083.1297	377.0220.01
R14	RL 0,35W 10,0KOHM+-1%TK50 RESISTOR DRALORIC SMA0207/10K-F-D	RL 083.1297	377.0220.01
R15	RL 0,35W 374 OHM+-1%TK50 RESISTOR DRALORIC SMA0207/374OHM-F-D	RL 083.0303	377.0220.01
R16	RL 0,35W 1MOHM+-1%TK50 RESISTOR DRALORIC SMA0207/1M-F-D	RL 082.7862	377.0220.01
R17	RL 0,21W 2,21KOHM+-1%TK50 RESISTOR RESISTA MK1 2K21 1% TK50	RL 092.1480	377.0220.01
R18	RL 0,35W 2,21KOHM+-1%TK50 RESISTOR DRALORIC SMA 0207/2,21K-F-C	RL 082.2477	377.0220.01
R19	RL 0,35W 1,21KOHM+-1%TK50 RESISTOR DRALORIC SMA0207/1,21K-F-D	RL 083.0655	377.0220.01
R20	RL 0,21W 332 OHM+-1%TK50 RESISTOR RESISTA MK1 332OHM 1% TK50	RL 092.1380	377.0220.01
R21	RL 0,21W 4,75KOHM+-1%TK50 RESISTOR RESISTA MK1 4K75 1% TK50	RL 092.1521	377.0220.01
RS1	SN 12V 1XU AU-CG MONOSTAB RELAY SDS RS-12V	SN 063.7083	377.0220.01
ST231	FP INDIREKT.STECKERL.36P. PIN CONNECTOR BERG 75160-102-36 3-POLIG	FP 242.3600	377.0220.01
T1	AK BCY59IX NPN 45V 200MA TRANSISTOR SIEMENS BCY59IX	AK 010.5163	377.0220.01
T2	AK 2N2369A NPN 15V 200MA TRANSISTOR VALVO 2N2369A	AK 010.4680	377.0220.01
T3	AK BFX48 PNP 30V 100MA TRANSISTOR SGS BFX48	AK 010.3202	377.0220.01

377.0214.00 SA BL 3+

Für diese Unterlage behalten wir  
uns alle Rechte vor



ROHDE & SCHWARZ

ÄZ Datum  
Date  
07 0586

Schaltteilliste für  
Parts list for  
ZE HF-EICHLLEITUNG  
ATTENUATION SET

Sachnummer  
Stock No.

377.0214.00 SA

Blatt  
Page

4

Kennzeichen Component No.	Benennung/Beschreibung Designation	Sachnummer Stock No.	enthalten in contained in
T4	AK 2N2369A NPN 15V 200MA TRANSISTOR VALVO 2N2369A	AK 010.4680	377.0220.01
Y301	ZE BAUGR. EICHLLEITUNG F.S	377.0250	- ENDE -

Für diese Unterlage behalten wir  
uns alle Rechte vor

377.0214.00 SA BL 4-



ROHDE & SCHWARZ

ÄZ Datum  
Date  
15 0586

Schalteilliste für  
Parts list for  
BAUGR. EICHLITUNG F.S  
ATTENUATOR SET FOR SMS

Sachnummer  
Stock No.  
302.7311.00 SA

Blatt  
Page  
1

Kennzeichen Component No.	Benennung/Beschreibung Designation	Sachnummer Stock No.	enthalten in contained in
A	ZUGEH. STROML. / CIRC. DIAGR. 302.7311 S		
B1	BJ SN75361AP 2XTTL/MOS-LC LEVEL CONVERTER NSC DS75361N	BJ 294.8490	294.8477
BIS/TO			
B5			
B6	BL SN74LS32N 4/2 INP. OR IC OR GATE SN74LS32N TEXAS SN74LS32N	266.4687	294.8477
BU1	FJ EINBAUBUCHSE SYST. SMA SOCKET SUHNER 22SMA-50-0-26	FJ 294.8154	294.8025
BU2	FJ EINBAUBUCHSE SYST. SMA SOCKET SUHNER 22SMA-50-0-26	FJ 294.8154	294.8025
BU10	FR JC-FASSUNG 16 POLIG 16-PIN IC-SOCKET PRECICONT US016T	FR 249.6091	294.8477
C1	CE 100UF-10+50% 25V 13X13 ELECTROLYTIC CAPACITOR ROEDERST ELKOEK100/25	CE 208.4007	294.8477
BIS/TO			
C9			
C10	CE 47UF-10+50% 40V 9X13 ELECTROLYTIC CAPACITOR ROEDERST EK 00 CB 247 G	CE 006.7142	294.8477
C11	CE 1UF -10+50% 63V 9X13 ELECTROLYTIC CAPACITOR ROEDERST ELKO EK 1/63	CE 022.7620	294.8477
R1	DT DAEMPfungSGLIED 4DB/50 ATTENUATOR 4DB/50	912.5230	294.8025
R2	DT DAEMPfungSGLIED 40DB/50 ATTENUATOR 40DB/50	912.5269	294.8025
R3	DT DAEMPfungSGLIED 10DB/50 ATTENUATOR 10DB/50	912.5246	294.8025
R4	DT DAEMPfungSGLIED 20DB/50 ATTENUATOR 20DB/50	912.5252	294.8025
R5	DT DAEMPfungSGLIED 40DB/50 ATTENUATOR 40DB/50	912.5269	294.8025
R6	DT DAEMPfungSGLIED 4DB/50 ATTENUATOR 4DB/50	912.5230	294.8025
R7	DT DAEMPfungSGLIED 2DB/50 ATTENUATOR 2DB	912.5223	294.8025
R8	DT DAEMPfungSGLIED 20DB/50 ATTENUATOR 20DB/50	912.5252	294.8025
R9	DT DAEMPfungSGLIED 1DB/50 ATTENUATOR 1DB/50	912.5217	294.8025
RS1	ZM ELEKTROMAGNET ELECTROMAGNET	294.8425	294.8090
BIS/TO			

302.7311.00 SA BL 1+

Für diese Unterlage behalten wir  
uns alle Rechte vor



**ROHDE & SCHWARZ**

ÄZ Datum  
Date  
15 0586

Schaltteilliste für  
Parts list for  
BAUGR. EICHLITUNG F.S  
ATTENUATOR SET FOR SMS

Sachnummer  
Stock No.  
302.7311.00 SA

Blatt  
Page  
2

Kennzeichen Component No.	Benennung/Beschreibung Designation	Sachnummer Stock No.	enthalten in contained in
RS9			- ENDE -

302.7311.00 SA BL 2-

für diese Umenage behalten wir  
uns alle Rechte vor

leitung und - Sicherung  
ator and RF protection

Y 301 HF - Eichleitung  
RF - attenuator  
(s. 377.0250 S)

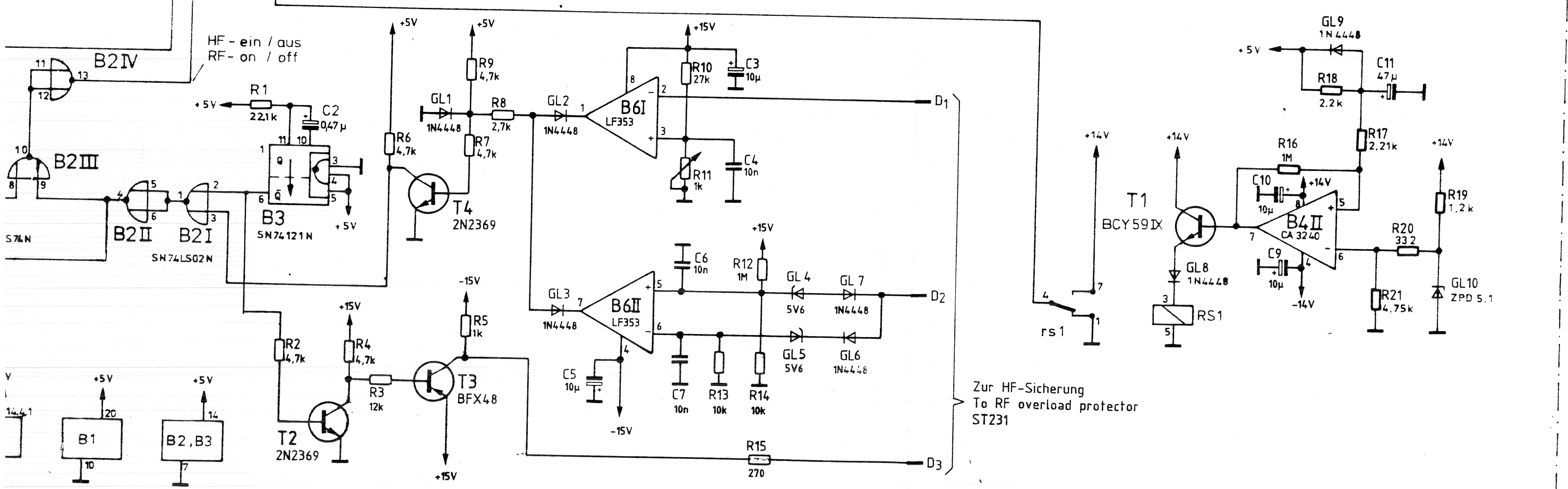
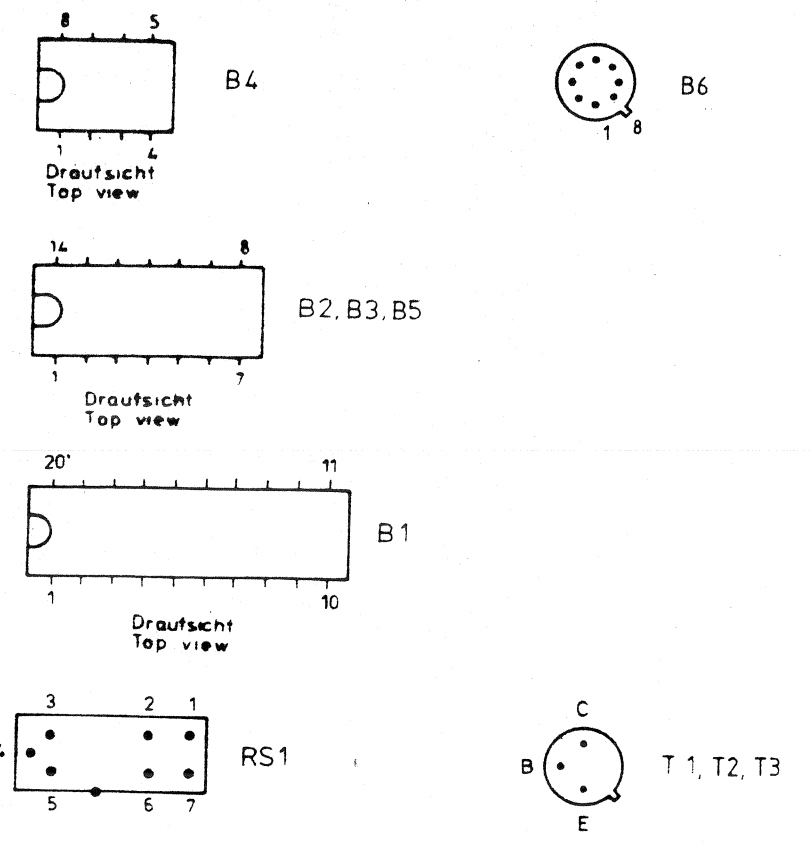
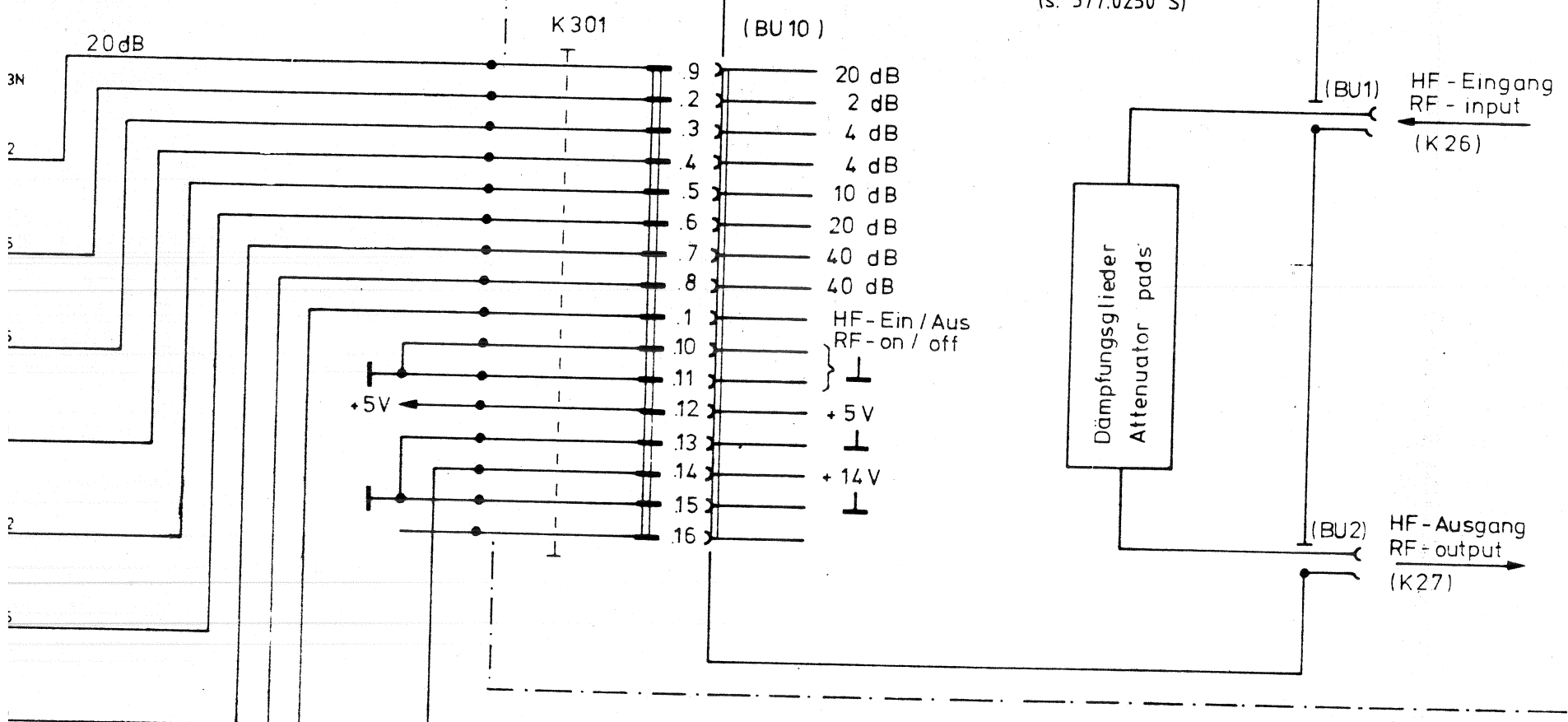

Zur HF-Sicherung  
To RF overload protector  
ST231

Z	Stromlauf zu	HF - Eichleitung RF - attenuator	Zeichn. Nr. 377.0214 S
			376.8011 V    376.8011

Steuerung für HF-Eichleitung und -Sicherung  
Control for RF-attenuator and RF protection  
377.0220

Y 301 HF - Eichleitung  
RF - attenuator  
(s. 377.0250 S)

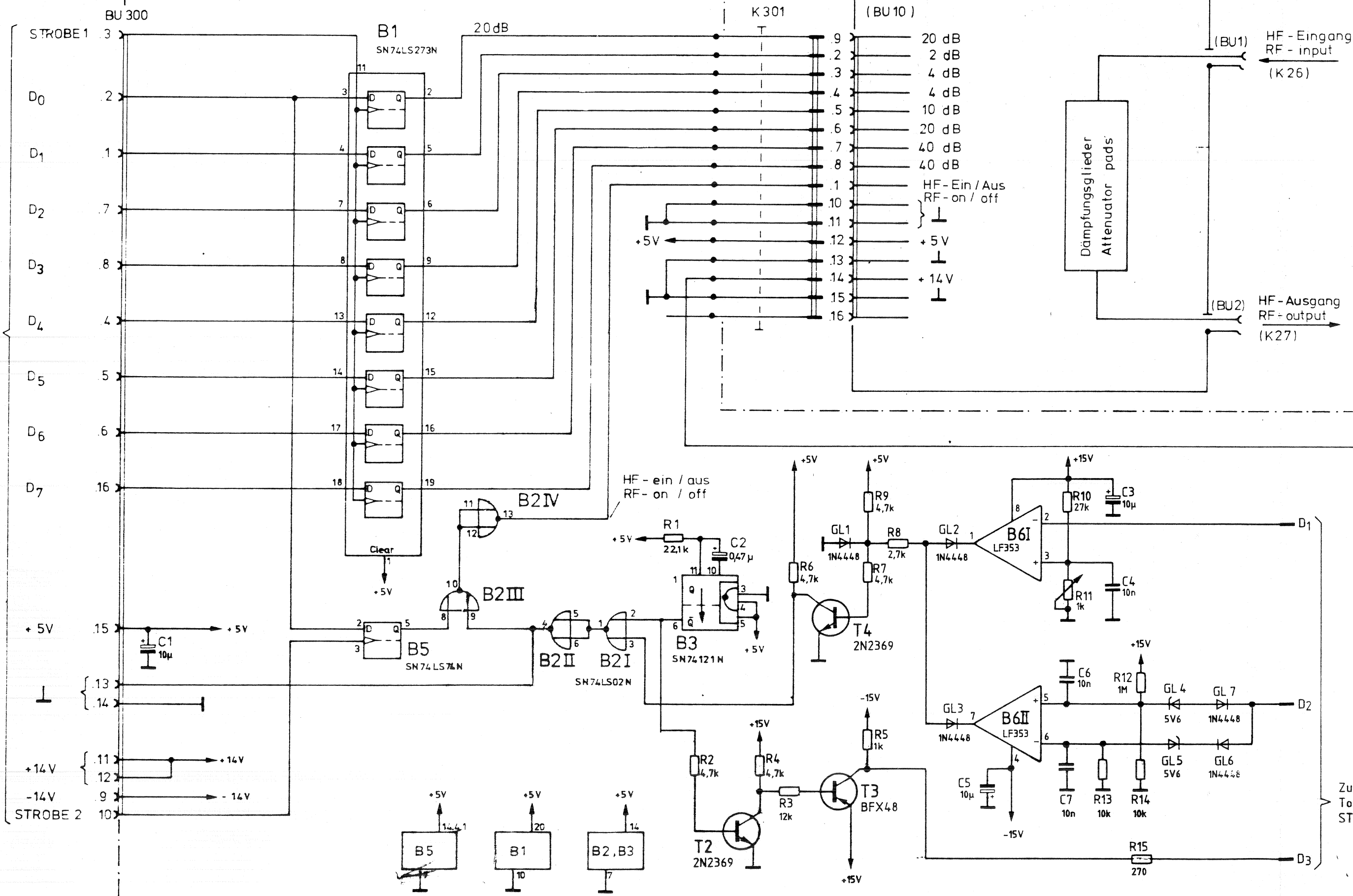

zum Mother-board to Mother-board

Zur HF-To RF c ST231

ROHDE & SCHWARZ · MÜNCHEN  
 unbefugte Verwertung, Mitteilung an andere ist strafbar und schadenzuzurechnend.

5.84	GS	B	32900	04.85	GS
		C	32946	12.85	Ho





A  
B  
C  
D  
E  
F

Ansicht und Leitungsführung Bauteilseite  
View of tracks on component side

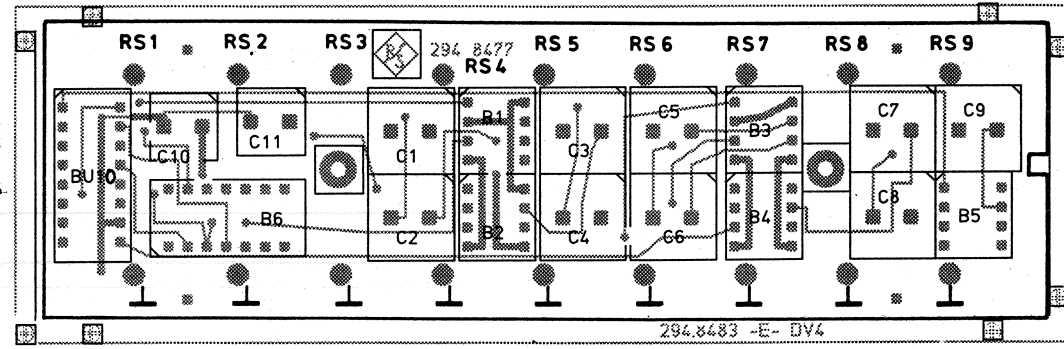

Ansicht und Leitungsführung Lötseite  
View of tracks on solder side

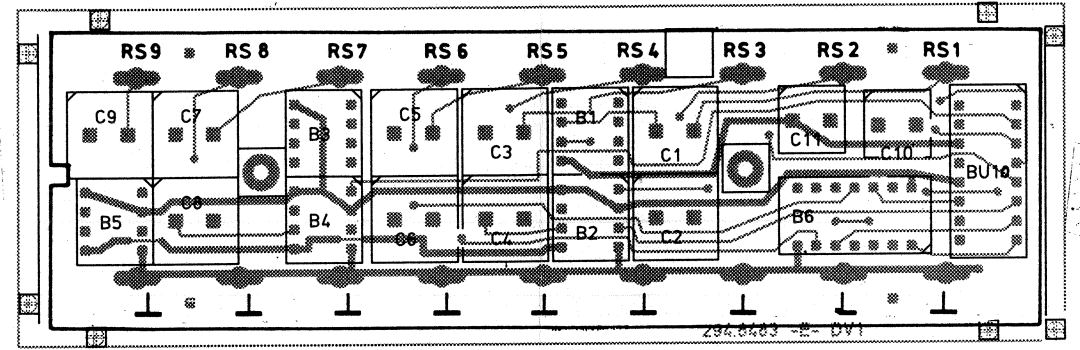

Für diese Zeichnung behalten wir uns alle Rechte vor

Versorg-Nr				J.B. Sachnr	
D	9.78	Nk	Maße ohne Toleranzangabe	Maßstab 1 : 1	Hersteller
E	25525	11.79			
			1GM	Menge	
			12.9.78	Nk	Ansteuerung 1
					Control unit 1
			294.8477		Blatt-Nr 2
			294 8019 V		294 8019

Ansicht und Leitungsführung Bauteilseite  
View of tracks on component side

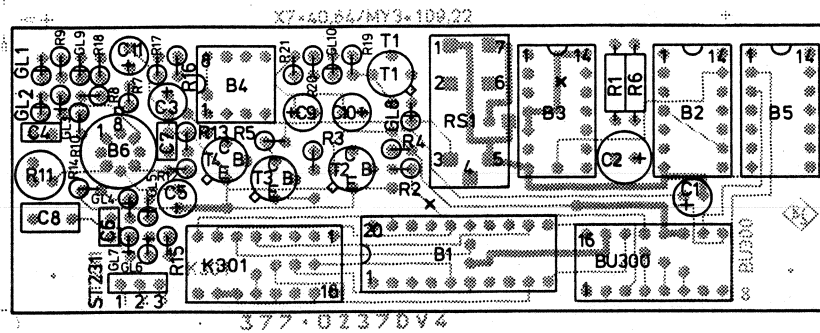

Ansicht und Leitungsführung Lötseite  
View of tracks on solder side

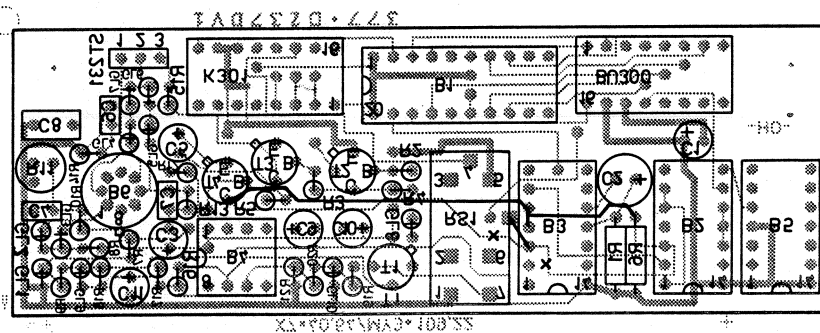

Für diese Unterlage behalten wir uns alle Rechte vor.

A	32900	4.85	GS	Maße ohne Toleranzangabe	Maßstab 1 : 1	Halbzeug, Werkstoff			
B	32946	10.86	GS						
				1KGA	Tag	Name	Benennung Steuerung für HF- Eichleitung und Sicherung CONTROL FOR RF-ATTENUATOR AND RF-PROTECTION	Z	
				Bearb.	06.84	GS			
				Gepr.					
				Norm					
						Zeichn.-Nr.	377.0220	Blatt-Nr.	
And Zust	Anderungs-Mitteilung	Tag	Name			v		Bl	
				zu Gerät	SMPD	reg. i. V.	376.8011 V	erste Z	377.0214



**ROHDE & SCHWARZ**

SERVICE INSTRUCTIONS

Crystal Oscillator Board

300.2412 (Y40)

# Table of Contents

		Page
<u>5</u>	<u>Service Instructions for</u>	
	<u>Crystal Oscillator Board 300.2412 (Y40)</u> .....	5.1
5.1	Circuit Description .....	5.1
5.1.1	Crystal Oscillator 300.5634 .....	5.1
5.1.2	Temperature Controller 300.5611 .....	5.1
5.2	Checking and Adjustment Procedures .....	5.2
5.2.1	Frequency Adjustment .....	5.2
5.2.2	Temperature Effect .....	5.2
5.2.3	Checking the Output Voltages .....	5.2
5.2.4	Checking the Oscillator Switch-off .....	5.3
5.3	Troubleshooting .....	5.3
5.3.1	Interfaces .....	5.3

Parts list  
Circuit diagram  
Components location plan

**5.1**                    **Circuit Description**

(See circuit diagram 300.2412 S)

All components of the crystal oscillator are housed in a thermally well-insulated casing to ensure the required high frequency stability. The oscillator crystal Q1 is kept at a constant temperature in an oven.

**5.1.1**                    **Crystal Oscillator 300.5634**

Q1 together with the capacitors C3 to C9 forms a series resonant circuit. Feedback is effected via the emitter of T1. The 10-MHz frequency is applied via C11, buffer amplifiers T2, T3, T4 and C30 to BU215. The control voltage derived from the collector of T3 via the diodes GL2, GL3 controls the gain of transistor T1 so that the load on the crystal or oscillator amplitude remains virtually constant. The trimmer R80 (accessible from the rear panel) is used for fine adjustment of the crystal frequency via the varicaps GL1 and GL11. The coarse adjustment is made with C3. The capacitors C4 and C5 differ according to the crystal series. The temperature coefficients of the two capacitors are chosen such that the temperature regulation keeps the effect of the ambient temperature on the frequency within the guaranteed limits. The 10-MHz reference frequency is available at BU215 for external use. If it is, however, intended for use as internal reference of the XPC/SMPC it is applied to Y5 and the motherboard via the shorting cable K30 and the amplifier stages T5, T6. An external 10-MHz reference (0.2 to 2 V) can be fed into BU216. T5, T6 boost the signal to the required level.

**5.1.2**                    **Temperature Controller 300.5611**

The transistors T54 and T55 provided on the outside of the oven casing are used as heater supply. They are driven from the differential amplifier T50, T51 via T52 and T53. The nominal temperature which is determined by the zero coefficient temperature of the crystal can be adjusted by means of R52. The thermistors R70 and R71 which are glued into the oven casing act as temperature sensors.

## 5.2 Checking and Adjustment Procedures

### 5.2.1 Frequency Adjustment

For new adjustment of the frequency because of aging only step b) must be carried out.

- a) Remove the crystal oscillator from the insulated casing. Solder C4 and C5 in place (value:  $C4 + C5 \approx 100$  pF). Set frequency trimmer C3 and potentiometer R80 to mid-position. Unsolder R52 and connect resistor decade to line I<sub>H</sub>. Connect voltages to soldering pins as in the casing. Adjust the resistor decade so that the temperature in the crystal casing corresponds to the zero coefficient temperature of the crystal to be built in. Insert crystal.
- b) Measure with calibrated frequency counter at 10-MHz output (BU205 DC load  $<500 \Omega$ ). Vary C4 and C5 until the output frequency =  $10 \text{ MHz} \pm 10 \text{ Hz}$ . Guidance values for temperature coefficients of C4 and C5:

$$C4 = 40\% \text{ of } C4 + C5 \text{ with } TC = -750 \times 10^{-6} / ^\circ\text{C}$$
$$C5 = 60\% \text{ of } C4 + C5 \text{ with } TC = 0 \pm 30 \times 10^{-6} / ^\circ\text{C}.$$

Place the crystal oscillator into the insulated casing.

- c) Adjustment of resistor decade for minimum frequency. Solder next higher or lower resistor of resistor series E12 in place as fixed value for R52.

### 5.2.2 Temperature Effect

Expose crystal oscillator to a temperature difference of  $30^\circ\text{C}$  (e.g.  $+25^\circ\text{C}$  to  $+55^\circ\text{C}$ ) in climatic chamber. Measure at BU215 after about 2 hours with calibrated frequency counter.

Frequency drift:  $\Delta f/f = 1 \times 10^{-9} / ^\circ\text{C}$  or  $0.3 \text{ Hz}/30^\circ\text{C}$ , max.

### 5.2.3 Checking the Output Voltages

Measure the output voltage at BU215 by means of oscilloscope. Nominal voltage: approximately  $0.5 V_{\text{rms}}$  into  $50 \Omega$ .

Measure the output voltage at K210/211 by means of oscilloscope.

Voltage at K210: approximately  $1.4 V_{\text{pp}}$   
Voltage at K211: approximately  $3.7 V_{\text{pp}}$ .

### 5.2.4 Checking the Oscillator Switch-off

Connect oscilloscope to BU215. No signal should be present with AC coupling. With a feed-through termination (50 to 75  $\Omega$ ) the 10-MHz signal should exhibit an amplitude of approx. 1 V( $V_{pp}$ ).

### 5.3 Troubleshooting

If a frequency cannot be measured at BU215 first measure the level at the base of T1 and T2. It is about 200 mV<sub>rms</sub>. Then measure the following DC voltages:

Emitter T2: approximately 4.8 V  
 Emitter T3: approximately 2.7 V  
 Emitter T4: approximately 2.8 V

If the temperature controller does not heat measure the DC voltage at point 17 (base of T54). While cold this voltage should be about 11 to 12 V. When the heating temperature is reached (70°C to 80°C) this voltage must rise.

#### 5.3.1 Interfaces

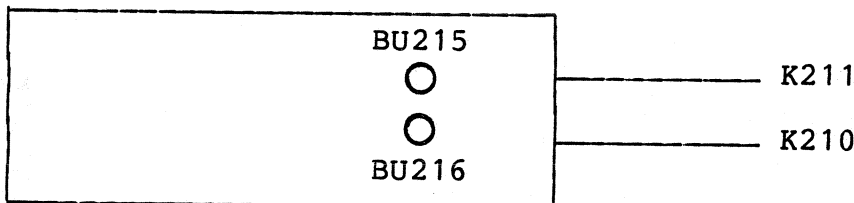

ST/BU	BU215	BU216
f	10 MHz	10 MHz
Level	0.5 V <sub>rms</sub>	0.2 to 2 V <sub>rms</sub>
Z	50 $\Omega$	> 500 $\Omega$
AC-DC	AC	AC
Shape of curve	sinusoidal	sinusoidal

ST/BU	K210	K211
f	10 MHz	10 MHz
Level	1.4 V <sub>pp</sub>	3.7 V <sub>pp</sub>
Z	< 100 $\Omega$	< 50 $\Omega$
AC-DC	DC	DC
Shape of curve	rectangular	rectangular





ROHDE & SCHWARZ  
MÜNCHEN

Schaltteillisten  
Stromläufe  
Bestückungspläne  
Parts lists  
Circuit diagrams  
Components plans

**ROHDE & SCHWARZ**

ÄZ	Datum
26	0686

Schaltteilliste für
Parts list for
ZE 10MHZ-QUARZOSZILLATOR
10 MHZ CRYSTAL OSCILLATOR

Sachnummer
Stock No.
300.2412.00 SA

Blatt
Page
1

Kennzeichen Component No.	Benennung/Beschreibung Designation	Sachnummer Stock No.	enthalten in contained in
BU215	FJ WINKELEINBAUBUCHSE BNC CONNECTOR	FJ 082.6708	
BU216	ROSENBERG 51K202-200P4 FJ WINKELEINBAUBUCHSE BNC CONNECTOR	FJ 082.6708	
C1	ROSENBERG 51K202-200P4		
C1	CK 1UF+-10%50V5RM MKT CAPACITOR	CK 099.2998	300.5634
C3	WIMA MKS2/50/1UF/10% CT 9,2PF TAUCHTR.RD 7X12 AIR-TYPE TRIMMER	CT 025.7373	300.5634
C4	TEKELEC LUFTTRAT5201MMUTTER TRIMMWERT / SELECTED		300.5634
C5	TRIMMWERT / SELECTED		300.5634
C6	CC 10NF+80-20%HDK6000 CERAMIC CAPACITOR	022.0610	300.5634
C7	THOMSON PEX607FB AER CG 150PF+-1%TKD9X9X6RM5 MICA CAPACITOR	CG 068.2773	300.5634
C8	JAHRE 48.10/F/150/1/500 CG 330PF+-1%TKD9X9X6RM5 MICA CAPACITOR	CG 068.2815	300.5634
C9	JAHRE 48.10/F/330/1/500 CC 10NF+80-20%HDK6000 CERAMIC CAPACITOR	022.0610	300.5634
C10	THOMSON PEX607FB AER CC 10NF+80-20%HDK6000 CERAMIC CAPACITOR	022.0610	300.5634
C11	THOMSON PEX607FB AER CC 1 NF+50-20%5HDK4000 CERAMIC CAPACITOR	006.0490	300.5634
C12	VALVO 2222 655 53102 CC 4,7NF+-20%400V RD8R600 CERAMIC CAPACITOR	092.3953	300.5634
C13	DRALORIC SDPN8 4,7NF-20+50%R6 CC 1 NF+50-20%5HDK4000 CERAMIC CAPACITOR	006.0490	300.5634
C14	VALVO 2222 655 53102 CC 4,7NF+-20%400V RD8R600 CERAMIC CAPACITOR	092.3953	300.5634
C15	DRALORIC SDPN8 4,7NF-20+50%R6 CC 10NF+80-20%HDK6000 CERAMIC CAPACITOR	022.0610	300.5634
C16	THOMSON PEX607FB AER CC 1 NF+50-20%5HDK4000 CERAMIC CAPACITOR	006.0490	300.5634
C17	VALVO 2222 655 53102 CC 1 NF+50-20%5HDK4000 CERAMIC CAPACITOR	006.0490	300.5634
C19	VALVO 2222 655 53102 TRIMMWERT / SELECTED		300.5634
C20	CC 10NF-20+50%7X8R6000 CAPACITOR	CC 087.7525	300.5634
	VALVO 2222 63051 64051103		

300.2412.00 SA BL 1+

Für diese Unterlage behalten wir  
uns alle Rechte vor

**ROHDE & SCHWARZ**

ÄZ	Datum
26	0686

Schalteilliste für
Parts list for
ZE 10MHZ-QUARZOSZILLATOR
10 MHZ CRYSTAL OSCILLATOR

Sachnummer
Stock No.
300.2412.00 SA

Blatt
Page
2

Kennzeichen Component No.	Benennung/Beschreibung Designation	Sachnummer Stock No.	enthalten in contained in
C22	CC 10NF-20+50%7X8R6000 CAPACITOR VALVO 2222 63051 64051103	CC 087.7525	300.5634
C23	CK 100NF+-5%63V5RM MKT CAPACITOR WIMA MKS/2/63/0,1UF/5%	CK 099.2930	300.5634
C24	CC 47NF+-10%50V5K1200VIEL CAPACITOR UNION CARB CK05BX473K	CC 082.7810	300.5634
C25	CC 47NF+-10%50V5K1200VIEL CAPACITOR UNION CARB CK05BX473K	CC 082.7810	300.5634
C26	CC 47NF+-10%50V5K1200VIEL CAPACITOR UNION CARB CK05BX473K	CC 082.7810	300.5634
C27	CC 12PF+-2%3X4NPO CAPACITOR VALVO 2222 678 10129	CC 087.6435	300.5634
C30	CC 10NF-20+50%7X8R6000 CAPACITOR VALVO 2222 63051 64051103	CC 087.7525	300.5634
C32	CK 100NF+-5%63V5RM MKT CAPACITOR WIMA MKS/2/63/0,1UF/5%	CK 099.2930	300.5634
C33	CC 47PF+-2%5X6NPO CAPACITOR VALVO 2222 678 10479	CC 087.6506	300.5634
C50	CC 10NF+80-20%HDK6000 CERAMIC CAPACITOR THOMSON PEX607FB AER	022.0610	300.5611
C51	CE 4,7UF+-20%35V 7X 5X11 ELECTROLYTIC CAPACITOR ERO-TANTAL TA-ELKOETR3-4,7/35	CE 022.8204	300.5611
GL1	AE BB109G 26/ 4PF CDI TUNING DIODE SIEMENS BB109G	AE 083.5970	300.5634
GL2	AE 5082-2800 SCHOTTKYDI DIODE HEWLETT-P. 5082-2800	AE 012.9066	300.5634
GL3	AE BZX79/C6V2 0,5W Z-DI ZENER DIODE VALVO BZX79/C6V2	AE 012.2461	300.5634
GL11	TRIMMWERT / SELECTED BB109G		300.5634
GL31	AD 1N4448 75V 0,15A UDI DIODE VALVO 1N4448	AD 012.0700	300.5634
K210	DX HF-KABEL RF-CABLE	300.8091	
K211	DX HF-KABEL RF-CABLE	300.8104	
L1	LD 5,60UH10%1,800HMG,195A CHOKE DELEVAN DROSSSEL1025-38	LD 067.2957	300.5634

300.2412.00 SA BL 2+

**ROHDE & SCHWARZ**AZ  
26Datum  
Date  
0686Schaltteilliste für  
Parts list for  
ZE 10MHZ-QUARZOSZILLATOR  
10 MHZ CRYSTAL OSCILLATORSachnummer  
Stock No.  
300.2412.00 SABlatt  
Page  
3

Kennzeichen Component No.	Benennung/Beschreibung Designation	Sachnummer Stock No.	enthalten in contained in
L4	LD 47,0UH10%4,500HMO,110A CHOKE DELEVAN DROSSEL1025-60	LD 067.3060	300.5634
L5	LD 22,0UH10%3,300HMO,114A CHOKE DELEVAN DROSSEL1025-52	LD 067.3024	300.5634
L6	LD 180 UH10%17,00HMO,057A CHOKE DELEVAN DROSSEL1025-74	LD 067.3130	300.5634
L7	LF ROHRK.RD3,5X1,2X3 GETR TUBLAR CORE VALVO 4312 020 31051	LF 026.9257	300.5634
L10	LD 10UH BEI 0,81A 0,66OHM CHOKE JAHRE 72.10-10ROK	LD 026.4126	
Q1	EQ 10,000MHZ3.CL50HC-27/U QUARTZ CRYSTAL UNIT 10MHZ QUAKE R&S ZCHNG.EQ090.7016	090.7039	300.2435
R1	RL 0,35W 100KOHM+-1%TK50 RESISTOR DRALORIC SMA0207/100K-F-C	RL 082.1764	300.5634
R2	RL 0,35W 47,5KOHM+-1%TK50 RESISTOR DRALORIC SMA/207/47,5K-F-C	RL 083.1800	300.5634
R3	RL 0,35W 10,0KOHM+-1%TK50 RESISTOR DRALORIC SMA0207/10K-F-D	RL 083.1297	300.5634
R4	RL 0,35W 100 OHM+-1%TK50 METALFILM-RESISTOR DRALORIC SMA0207/100/HM-F-D	RL 082.6543	300.5634
R5	RL 0,35W 1,50KOHM+-1%TK50 RESISTOR DRALORIC SMA0207/1,50K-F-D	RL 083.0732	300.5634
R6	RL 0,35W 1,21KOHM+-1%TK50 RESISTOR DRALORIC SMA0207/1,21K-F-D	RL 083.0655	300.5634
R7	RL 0,35W 1KOHM+-1%TK50 RESISTOR DRALORIC SMA0207/1K-F-C	RL 082.2160	300.5634
R8	RL 0,35W 18,2KOHM+-1%TK50 RESISTOR DRALORIC SMA/207/18,2K-F-C	RL 083.1480	300.5634
R9	RL 0,35W 12,1KOHM+-1%TK50 RESISTOR DRALORIC SMA0207/12,1K-F-D	RL 083.1351	300.5634
R10	RL 0,35W 1KOHM+-1%TK50 RESISTOR DRALORIC SMA0207/1K-F-C	RL 082.2160	300.5634
R11	RL 0,35W 47,5 OHM+-1%TK50 RESISTOR DRALORIC SMA0207/47,5OHM-F-D	RL 082.9507	300.5634
R12	RL 0,35W 3,32KOHM+-1%TK50 RESISTOR DRALORIC SMA0207/3,32K-F-D	RL 083.0990	300.5634

300.2412.00 SA BL 3+

Für diese Unterlage behalten wir  
uns alle Rechte vor



ROHDE & SCHWARZ

ÄZ Datum  
Date  
26 0686

Schalteilliste für  
Parts list for  
ZE 10MHZ-QUARZOSZILLATOR  
10 MHZ CRYSTAL OSCILLATOR

Sachnummer  
Stock No.  
300.2412.00 SA

Blatt  
Page  
4

Kennzeichen Component No.	Benennung/Beschreibung Designation	Sachnummer Stock No.	enthalten in contained in
R13	RL 0,35W 12,1KOHM+-1%TK50 RESISTOR DRALORIC SMA0207/12,1K-F-D	RL 083.1351	300.5634
R14	RL 0,35W 3,92KOHM+-1%TK50 RESISTOR RESISTA MK2	RL 083.1039	300.5634
R15	RL 0,35W 475 OHM+-1%TK50 RESISTOR DRALORIC SMA0207/475OHM-F-D	RL 083.0390	300.5634
R16	RL 0,35W 681 OHM+-1%TK50 RESISTOR DRALORIC SMA0207/681OHM-F-D	RL 083.0490	300.5634
R17	RL 0,35W 681 OHM+-1%TK50 RESISTOR DRALORIC SMA0207/681OHM-F-D	RL 083.0490	300.5634
R18	RL 0,35W 392 OHM+-1%TK50 RESISTOR DRALORIC SMA0207/392K-F-C	RL 082.2183	300.5634
R19	RL 0,35W 10,0KOHM+-1%TK50 RESISTOR DRALORIC SMA0207/10K-F-D	RL 083.1297	300.5634
R20	RL 0,35W 22,1KOHM+-1%TK50 RESISTOR DRALORIC SMA/207/22,1K-F-C	RL 083.1545	300.5634
R21	RL 0,35W 475 OHM+-1%TK50 RESISTOR DRALORIC SMA0207/475OHM-F-D	RL 083.0390	300.5634
R22	RL 0,35W 47,5 OHM+-1%TK50 RESISTOR DRALORIC SMA0207/47,5OHM-F-D	RL 082.9507	300.5634
R23	RL 0,35W 3,92KOHM+-1%TK50 RESISTOR RESISTA MK2	RL 083.1039	300.5634
R24	RL 0,35W 12,1KOHM+-1%TK50 RESISTOR DRALORIC SMA0207/12,1K-F-D	RL 083.1351	300.5634
R25	RL 0,35W 47,5 OHM+-1%TK50 RESISTOR DRALORIC SMA0207/47,5OHM-F-D	RL 082.9507	300.5634
R26	RL 0,35W 475 OHM+-1%TK50 RESISTOR DRALORIC SMA0207/475OHM-F-D	RL 083.0390	300.5634
R27	RL 0,35W 47,5 OHM+-1%TK50 RESISTOR DRALORIC SMA0207/47,5OHM-F-D	RL 082.9507	300.5634
R28	RL 0,35W 562 OHM+-1%TK50 RESISTOR DRALORIC SMA0207/562OHM-F-D	RL 083.0461	300.5634
R29	RL 0,35W 22,1KOHM+-1%TK50 RESISTOR DRALORIC SMA/207/22,1K-F-C	RL 083.1545	300.5634
R30	RL 0,35W 475 OHM+-1%TK50 RESISTOR DRALORIC SMA0207/475OHM-F-D	RL 083.0390	300.5634
R32	RL 0,35W 825 OHM+-1%TK50 RESISTOR DRALORIC SMA 0207/825OHM-F-C	RL 082.2502	300.5634

300.2412.00 SA BL 4+

uns alle Rechte vor

**ROHDE & SCHWARZ**

ÄZ	Datum
26	0686

Schaltteilliste für
Parts list for
ZE 10MHZ-QUARZOSZILLATOR
10 MHZ CRYSTAL OSCILLATOR

Sachnummer
Stock No.
300.2412.00 SA

Blatt
Page
5

Kennzeichen Component No.	Benennung/Beschreibung Designation	Sachnummer Stock No.	enthalten in contained in
R33	RL 0,35W 100 OHM+-1%TK50 METALFILM-RESISTOR	RL 082.6543	300.5634
R34	DRALORIC SMA0207/100/HM-F-D RL 0,65W 121 OHM+-1%TK50 METAL FILM RESISTOR	006.1921	300.5634
R35	RESISTA MK4 121 OHM 1% TK50 RL 0,35W 47,5 OHM+-1%TK50 RESISTOR	RL 082.9507	300.5634
R37	DRALORIC SMA0207/47,5OHM-F-D RL 0,35W 182 OHM+-1%TK50 RESISTOR	RL 083.0010	300.5634
R38	DRALORIC SMA0207/182OHM-F-D RL 0,35W 1MOHM+-1%TK50 RESISTOR	RL 082.7862	300.5634
R39	DRALORIC SMA0207/1M-F-D RL 0,35W 4,75KOHM+-1%TK50 RESISTOR	RL 083.1097	300.5634
R50	DRALORIC SMA0207/4,75K-F-D RL 0,35W 22,1KOHM+-1%TK50 RESISTOR	RL 083.1545	300.5611
R52	DRALORIC SMA/207/22,1K-F-C TRIMMWERT		
R53	DRALORIC SMA 0207/2,21K-F-C RL 0,35W 2,21KOHM+-1%TK50 RESISTOR	RL 082.2477	300.5611
R54	DRALORIC SMA0207/4,75K-F-D RL 0,35W 4,75KOHM+-1%TK50 RESISTOR	RL 083.1097	300.5611
R55	DRALORIC SMA 0207/68,1K-F-C RL 0,35W 68,1KOHM+-1%TK50 RESISTOR	RL 082.2602	300.5611
R56	DRALORIC SMA0207/562OHM-F-D RL 0,35W 562 OHM+-1%TK50 RESISTOR	RL 083.0461	300.5611
R57	DRALORIC SMA0207/3,32K-F-D RL 0,35W 3,32KOHM+-1%TK50 RESISTOR	RL 083.0990	300.5611
R58	DRALORIC SMA0207/15K-F-D RL 0,35W 15,0KOHM+-1%TK50 RESISTOR	RL 083.1400	300.5611
R59	DRALORIC LCA0207/+-5%5,6 RF 0,25W 5,6 OHM +-5% RESISTOR	074.0056	300.5611
R60	DRALORIC LCA0207/+-5%5,6 RF 0,25W 5,6 OHM +-5% RESISTOR	074.0056	300.5611
R70	VALVO NTC-WID.232262721104 RK HEISSEL100KOHM 20%,10W THERMISTOR	153.4430	300.2435
R71	VALVO NTC-WID.232262721104 RK HEISSEL100KOHM 20%,10W THERMISTOR	153.4430	300.2435
R80	VALVO NTC-WID.232262721104 RR 1 W 20 KOHM+-5% LITZE WIRE-WOUND POTENTIOMETER IR TYP60C-00-20KOHM	030.3520	

300.2412.00 SA BL 5+

Für diese Unterlage behalten wir  
uns alle Rechte vor



ROHDE & SCHWARZ

ÄZ Datum  
Date  
26 0686

Schaltteilliste für  
Parts list for  
ZE 10MHZ-QUARZOSZILLATOR  
10 MHZ CRYSTAL OSCILLATOR

Sachnummer  
Stock No.  
300.2412.00 SA

Blatt  
Page  
6

Kennzeichen Component No.	Benennung/Beschreibung Designation	Sachnummer Stock No.	enthalten in contained in
T1	AK BF173 NPN 25V 25MA TRANSISTOR	010.4573	300.5634
T2	AEG-TELEF. BF173 AK BF173 NPN 25V 25MA TRANSISTOR	010.4573	300.5634
T3	AEG-TELEF. BF173 AK BF173 NPN 25V 25MA TRANSISTOR	010.4573	300.5634
T4	AEG-TELEF. BF173 AK 2N708 NPN 20V 200MA TRANSISTOR	AK 010.4467	300.5634
T5	VALVO 2N708 AK 2N708 NPN 20V 200MA TRANSISTOR	AK 010.4467	300.5634
T6	VALVO 2N708 AK 2N3209 PNP 20V 100MA TRANSISTOR	AK 010.3590	300.5634
T7	SGS 2N3209 AK BC337-40 NPN 45V 800MA TRANSISTOR	AK 303.9524	300.5634
T50	INTERMETAL BC337-40 AK BCY59IX NPN 45V 200MA TRANSISTOR	AK 010.5163	300.5611
T51	SIEMENS BCY59IX AK BCY59IX NPN 45V 200MA TRANSISTOR	AK 010.5163	300.5611
T52	SIEMENS BCY59IX AK BCY79IX PNP 45V 200MA TRANSISTOR	AK 010.3777	300.5611
T53	SIEMENS BCY79IX AK BCY79IX PNP 45V 200MA TRANSISTOR	AK 010.3777	300.5611
T54	SIEMENS BCY79IX AL BD236 PNP 60V 1A0 TRANSISTOR	AL 010.0361	300.2435
T55	VALVO BD236 AL BD236 PNP 60V 1A0 TRANSISTOR	AL 010.0361	300.2435
	VALVO BD236		- ENDE -

300.2412.00 SA BL 6-

uns alle Rechte vor



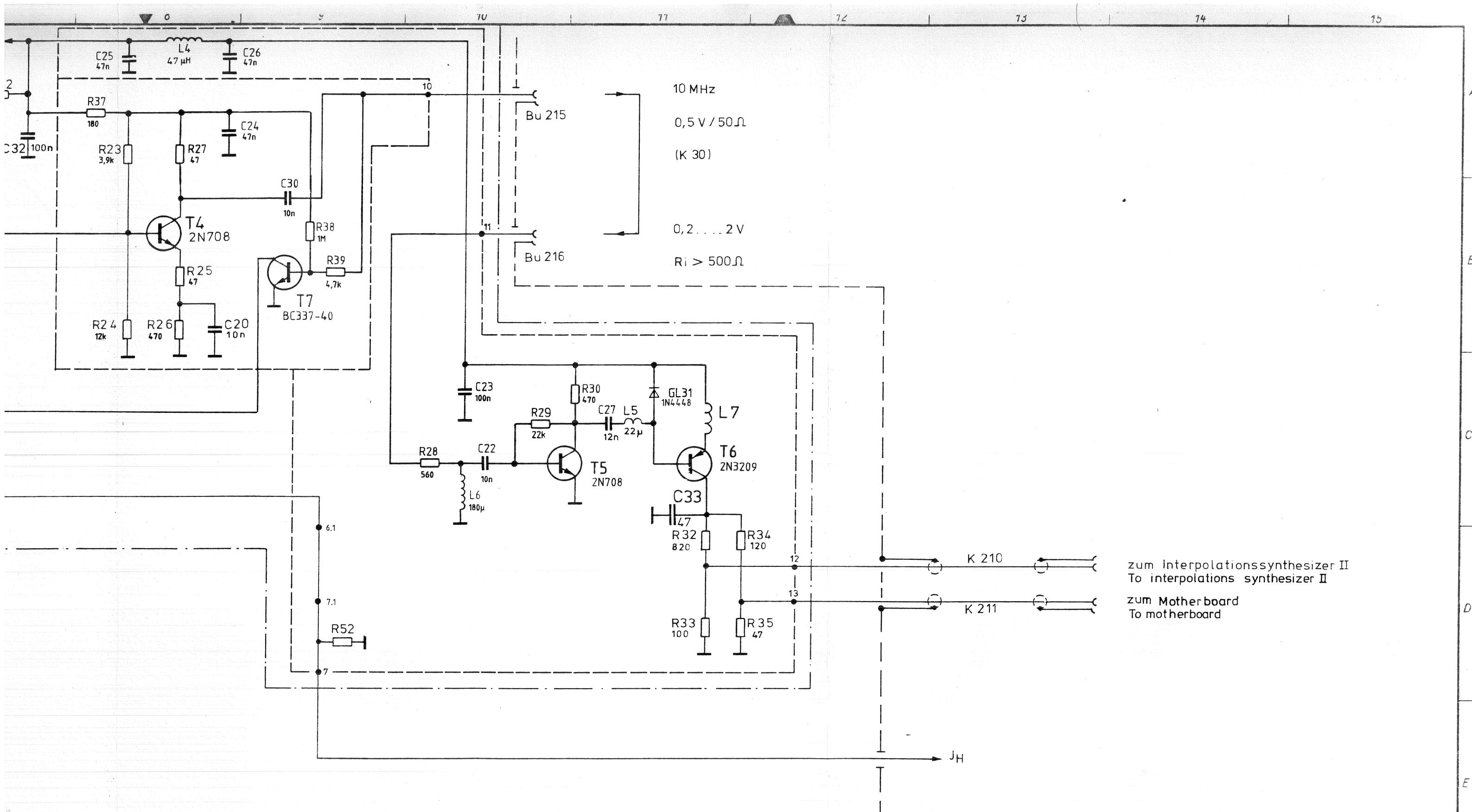

10 MHz  
 0,5 V / 50 Ω  
 (K 30)  
 0,2 ... 2 V  
 Ri > 500 Ω

zum Interpolationssynthesizer II  
 To interpolations synthesizer II  
 zum Motherboard  
 To motherboard

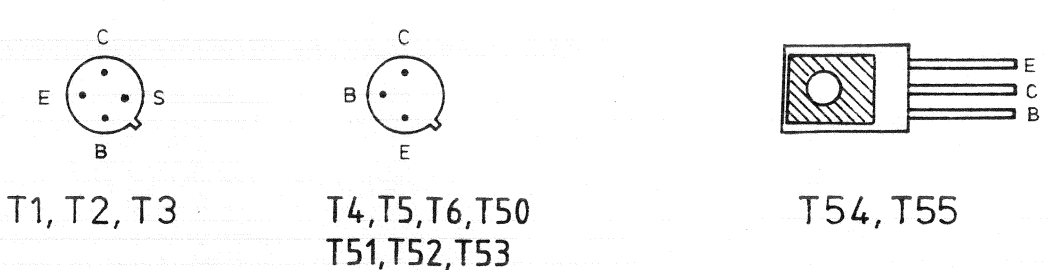

	Stromlauf zu	10 MHz Quarzoszillator	Zeichn. Nr. 300.2412 S 300.1000 V   300.1000
		10 MHz crystal oscillator	

G	30063	4.83	gs
H	30455	9.83	gs
J	31341	6.84	Gs

Diese Zeichnung ist unser Eigentum. Vervielfältigung, unbefugte Verwertung, Mitteilung an andere ist strafbar und schadenverursachend.  
**ROHDE & SCHWARZ MÜNCHEN**

gezeichnet	7	Kü
bearbeitet	2.19	Bp
geprüft	3.81	M
normgepr.		

Quarzoszillator  
Crystal oscillator  
300.5634

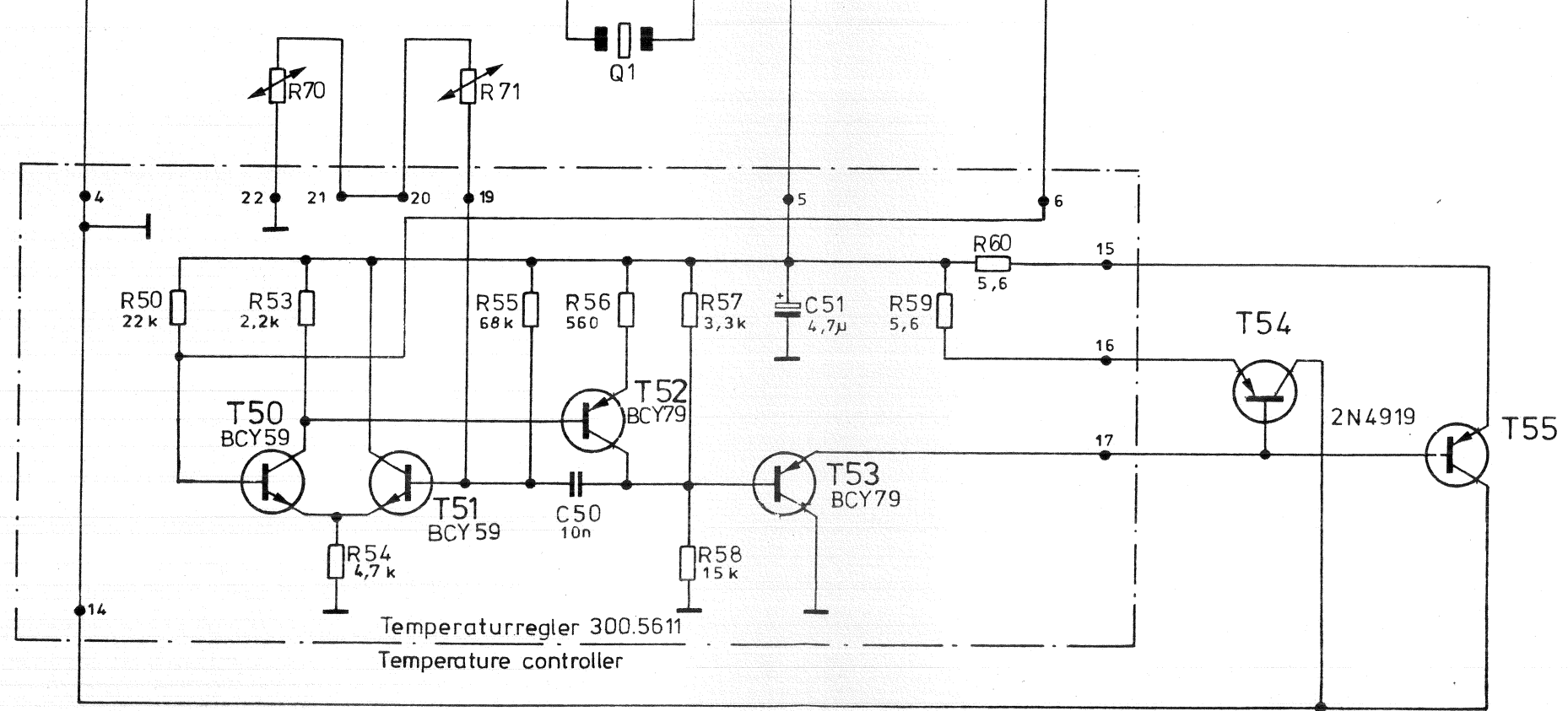
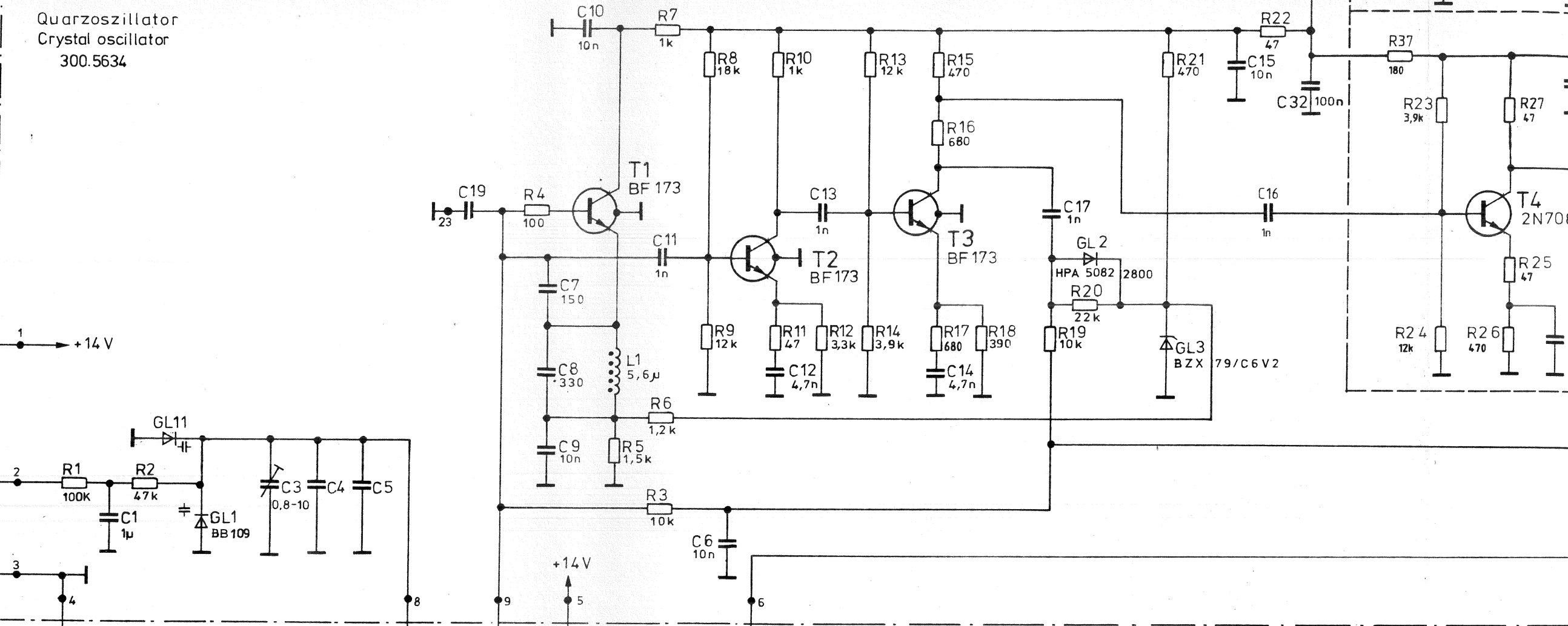
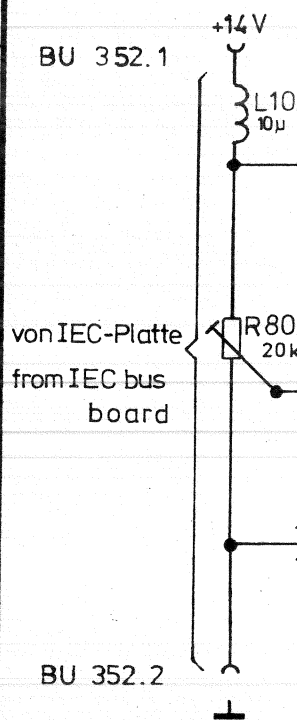

Temperaturregler 300.5611  
Temperature controller

Ansicht und Leitungsführung Bauteilseite  
View of tracks on component side

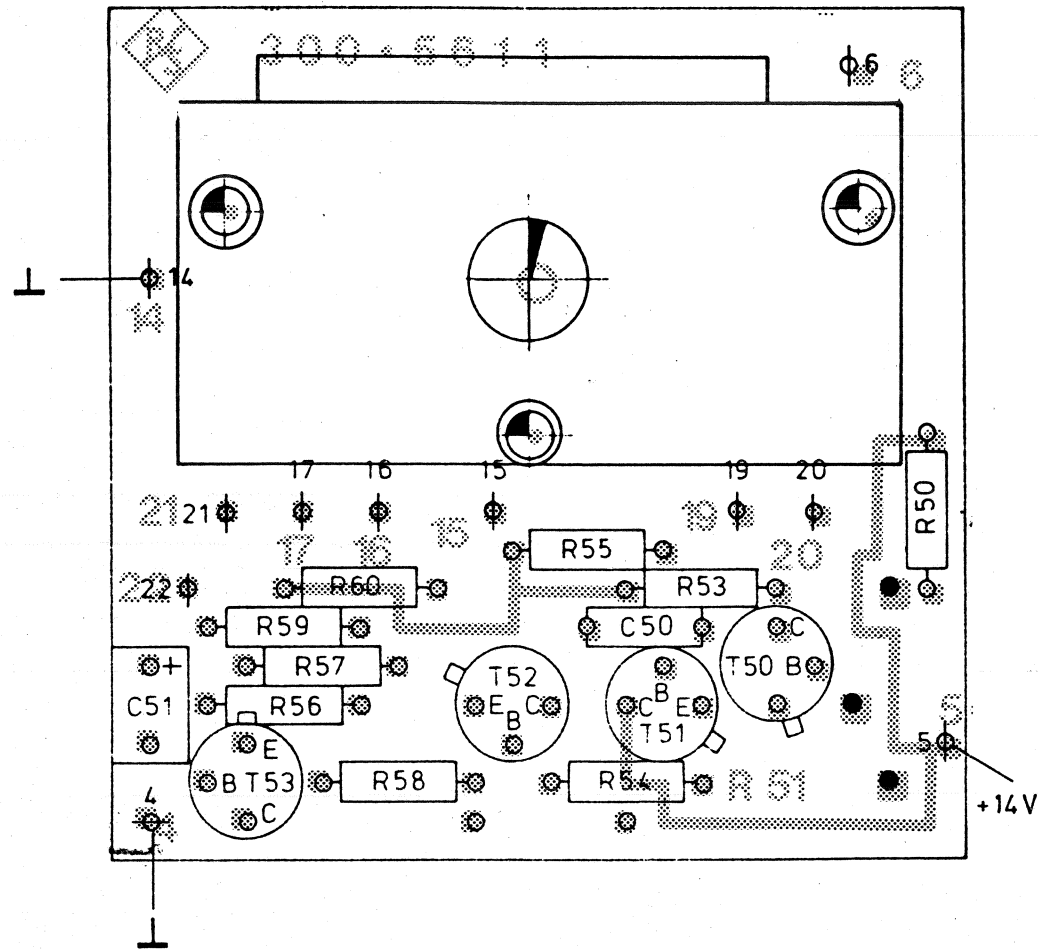

Ansicht und Leitungsführung Lötseite  
View of tracks on solder side

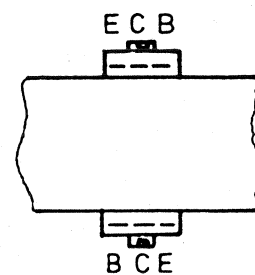
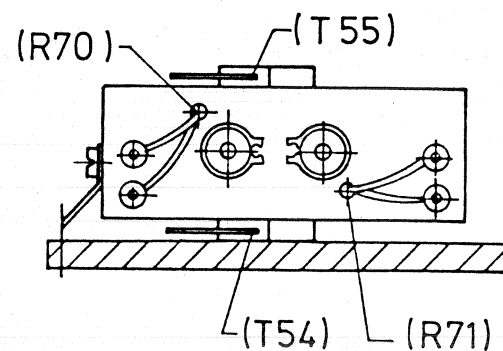
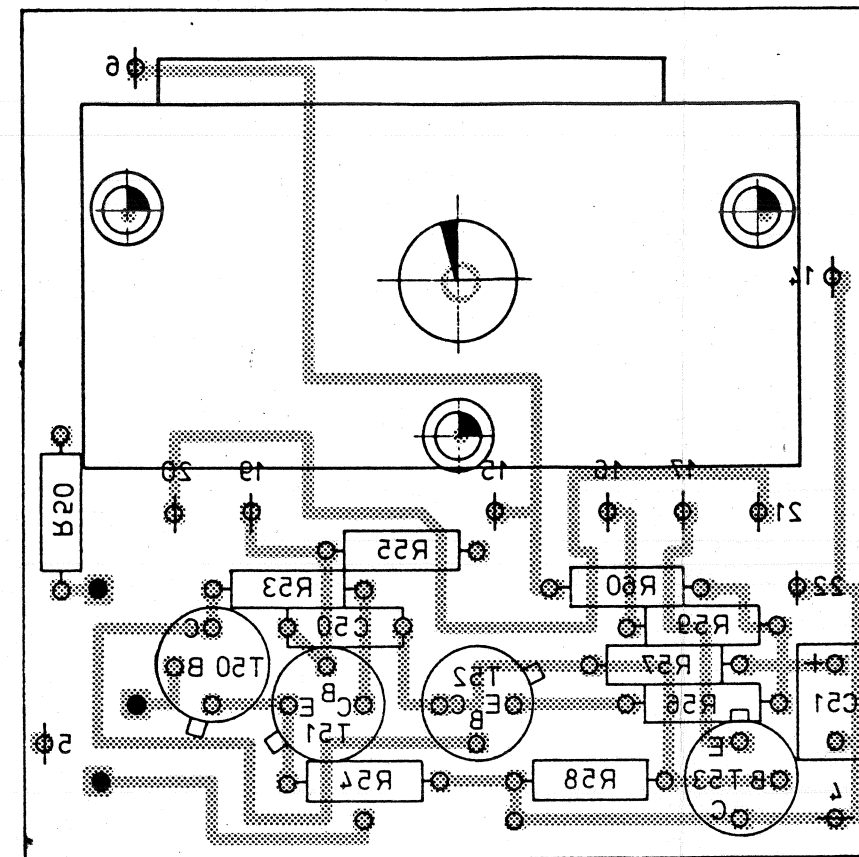

Name		300.5611		SMPC	
A ——— 2.79 Bg				Temperaturregler	
B ——— 12.80 LS				Temperature controller	
		300.2429		300.2429	
		300.2429		300.5611	
ROHE & S. WABZ		1GME 31 8 77Wm		2 29 35 2.81 M	

Ansicht und Leitungsführung Bauteilseite  
View of tracks on component side

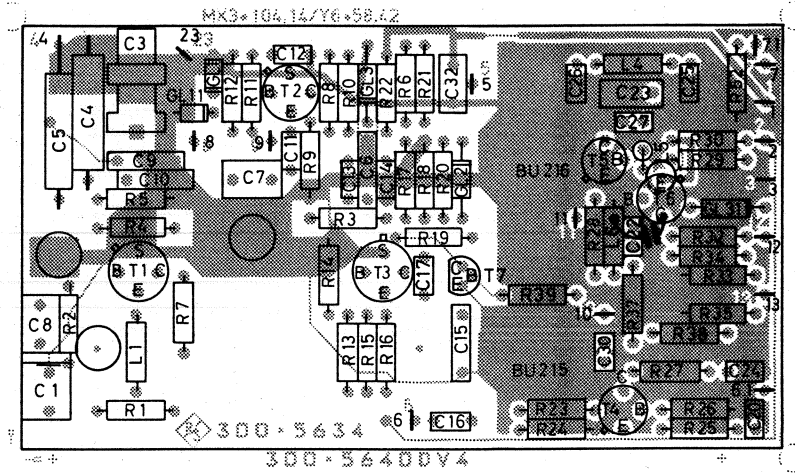

Ansicht und Leitungsführung Lötseite  
View of tracks on solder side

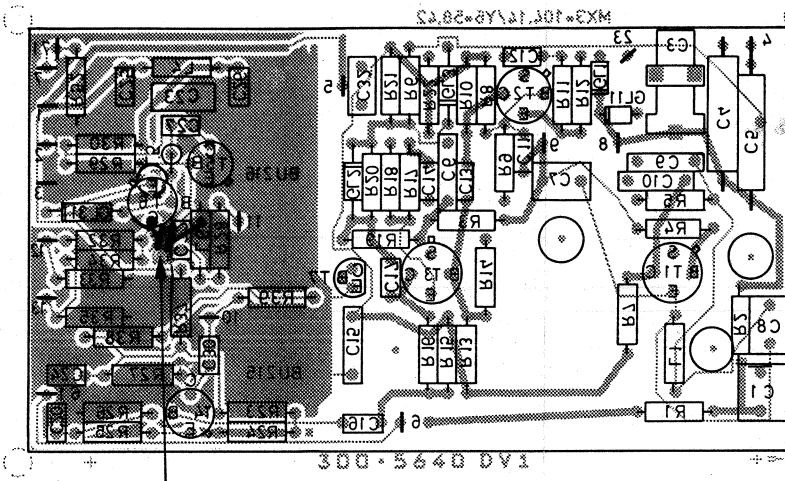

C33 v. T6/C → so kurz wie möglich auf Bauteilseite

Für diese Unterlage behalten wir uns alle Rechte vor.

L	31057	11.83	GS	Maße ohne Toleranzangabe	Maßstab 1 : 1	Halbzeug, Werkstoff			
M	31341	6.84	GS						
N	32288	6.85	GS						
				1GMC	Tag	Name	Benennung <b>Quarzoszillator</b> CRYSTAL OSCILLATOR	Z	
				Bearb.	11.83	GS			
				Gepr.					
				Norm					
				<b>ROHDE &amp; SCHWARZ</b>		Zeichn.-Nr.	300.5634	Blatt-Nr. 2	
And. Zust.	Anderungs-Mitteilung	Tag	Name	zu Gerät	SMPS	reg. V			300.1000V

ISC Injektion Methode E

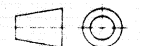



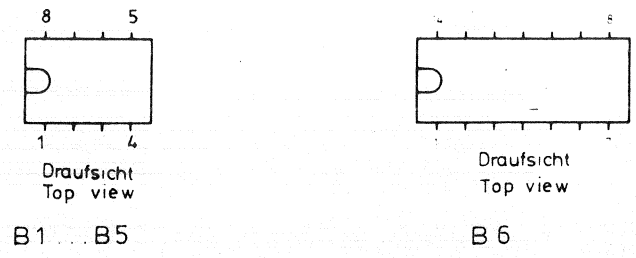
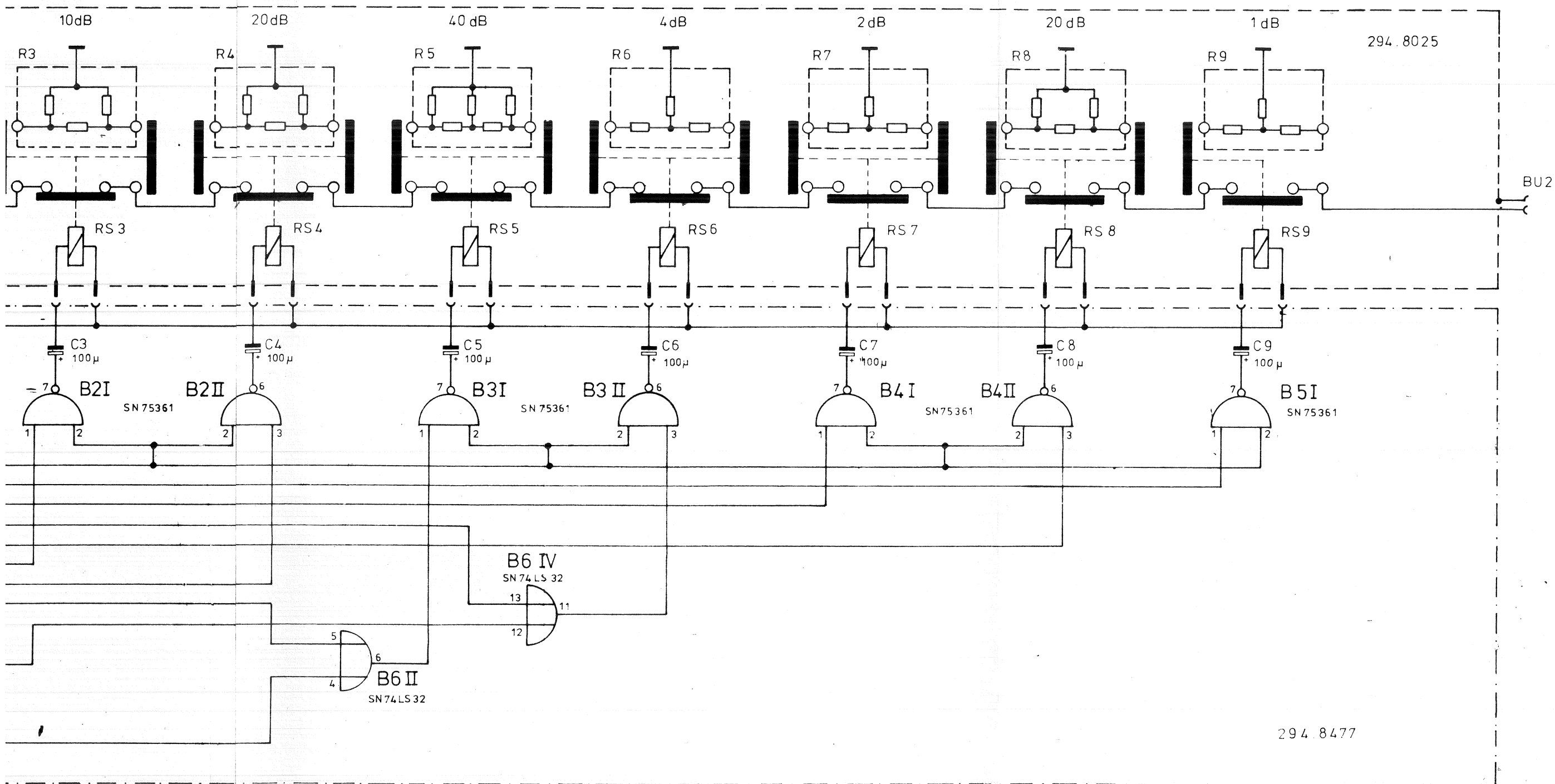

POLARAD Polarad

	Stromlauf zu	Baugruppe Eichleitung für SMS RF - Attenuator for SMS	Zeichn. Nr. 302.7311 S
	Z		302.4012 V

Dämpfungsglieder eingeschaltet bei High-Signal an den Eingängen.

Attenuator pads switched on High-signal at the inputs

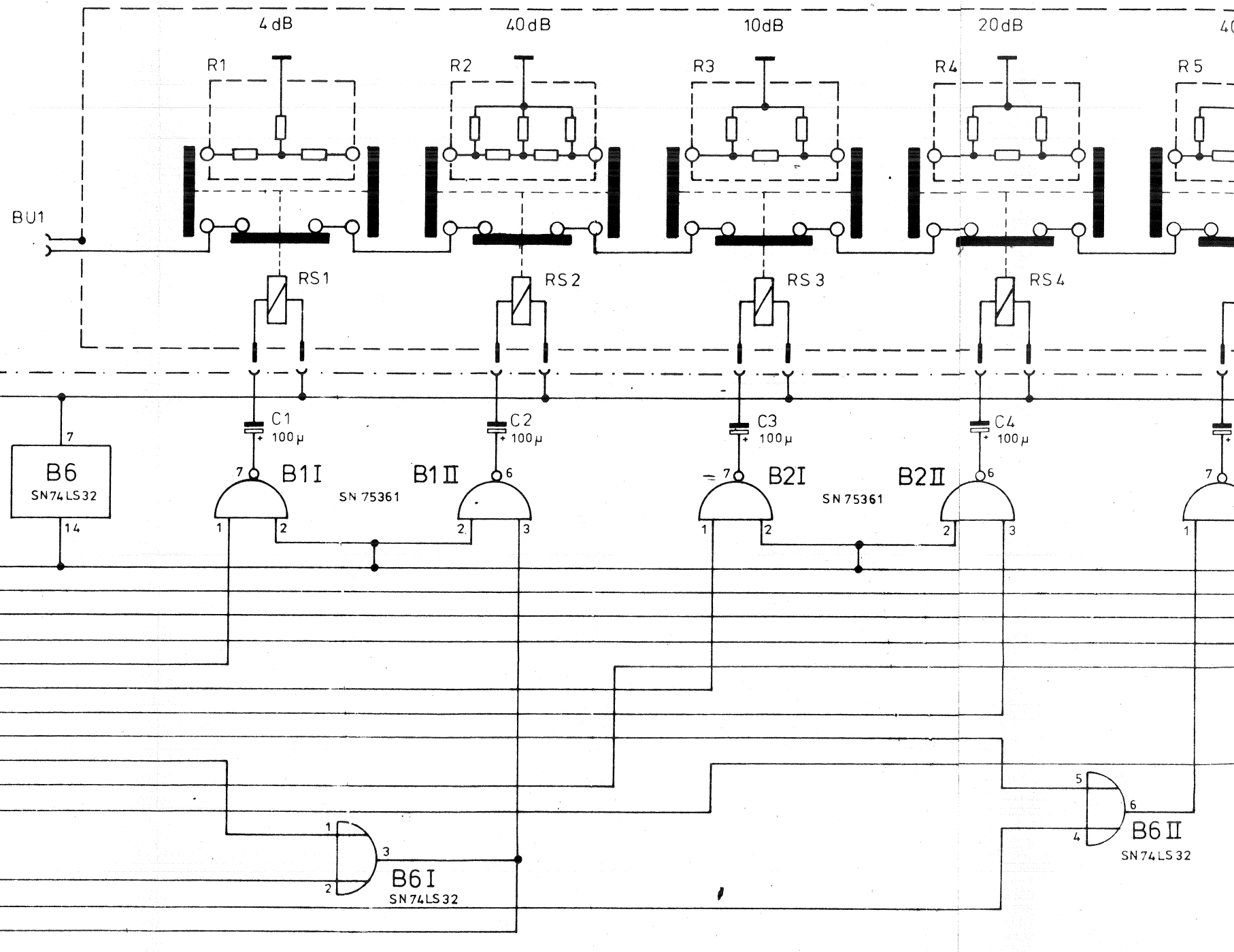

zu Gerät  
To measuring  
instrument

Diese Zeichnung ist unser Eigentum. Vervielfältigung, Verbreitung, Mitteilung an andere ist strafbar und schadenersatzpflichtig.  
**ROHDE & SCHWARZ MÜNCHEN**

gezeichnet	13.9.78	Hg	
bearbeitet	78	Gn	
geprüft			
abgegeben			
Nr.	A 24668	Mü	
	B 28 027	Gn	
	C 28613	ib	
Datum	02.79		



**ROHDE & SCHWARZ**

SERVICE INSTRUCTIONS

Controller

376.9418 (Y100)

Printed in West Germany



# Table of Contents

		Page
<u>5</u>	<u>Service Instructions for Controller</u>	
	<u>376.9418 (Y100)</u> .....	5.1
5.1	Functional Description .....	5.1
5.2	Checking the Controller .....	5.1
5.3	Troubleshooting .....	5.1
5.3.1	Interfaces .....	5.2

Parts list  
Circuit diagram  
Components location plans

### 5.1 Functional Description

(See circuit diagram 376.9418 S)

The function of the controller (Y100) is the storing and level conversion of the digital information supplied by processor (Y1) for the control of diode switch I (Y101), diode switch II (Y102) and filter (Y104).

Data word sent by the processor (Y1) for every change of frequency setting or for the switch on/off of the pulse modulator option is read into latch (B1). The control voltages for Y101, Y102 and Y104 are derived from the stored logical states with the aid of voltage comparators B2 I to IV, B3 I, II and the driver transistors T1 to T12 following the voltage comparators.

### 5.2 Checking the Controller

The check is carried out by referring to Table 5-1.

### 5.3 Troubleshooting

For signature analysis, refer to processor (Y1).

### 5.3.1 Interfaces

Table 5-1

ST 50i	.1	.2	.3	.4	.5	.6	.7	.8	.9	.10
$f < 21.25$ MHz	3	2	2	3	2	2	1	1	5	4
$21.25 < f < 1360$ MHz	2	3	2	2	3	2	1	1	5	4
$1360 < f < 1710$ MHz	2	2	3	2	2	3	5	1	1	4
$1710 < f < 2150$ MHz	2	2	3	2	2	3	1	5	1	4
$2150 < f < 2720$ MHz	2	2	3	2	2	3	1	1	5	4

1 =  $0.8 \pm 0.1$  V; 2 =  $+10 \pm 0.5$  V; 3 =  $-11 \pm 0.5$  V; 4 =  $22.9 \pm 0.1$  V; 5 =  $-10 \pm 0.5$  V;  
Specified range limits are within  $\pm 1$  Hz.

ST 500	.1	.2	.3	.4	.5	.6	.7	.8	.9	.10
PM off				*) $0 + 0.2V$				*) $0 + 0.2V$		
PM on	$+22.9 \pm 1V$	$+22.9 \pm 1V$	$-12 \pm 0.2V$	$4 \pm 1V$	$+12 \pm 0.1V$	$+12 \pm 0.1V$	$+5V \pm 0.2V$	$+12 \pm 0.1V$	0V	0V

ST 505 *)	.1	.2	.3	.4	.5
PM off			$0 + 0.2V$		
PM on	$+5 \pm 0.2V$	$-5 \pm 0.1V$	$+12 \pm 0.1V$	$-5 \pm 0.1V$	$+5 \pm 0.2V$

\*) Check only if pulse modulator option is fitted.

ST 503 *)	.1	.2
PM off	$+4 -1V$	
PM on	$+3 \pm 0.2V$	$+5V \pm 0.2V$

## Digital signals

1 strobe, data:      3 frequency ranges  
                           3 filter ranges  
                           1 pulse modulation

Table 5-2

	D7	6	5	4	3	2	1	0
$f < 21.25$ MHz	X	X	1	0	0	0	0	1
$21.25 < f < 1360$ MHz	X	X	1	0	0	0	1	0
$1360 < f < 1710$ MHz	X	X	0	0	1	1	0	0
$1710 < f < 2150$ MHz	X	X	0	1	0	1	0	0
$2150 < f < 2720$ MHz	X	X	1	0	0	1	0	0
PM off	X	0	X	X	X	X	X	X
PM on	X	1	X	X	X	X	X	X

Specified range limits are within  $\pm 1$  Hz



ROHDE & SCHWARZ  
MÜNCHEN

Schaltteillisten  
Stromläufe  
Bestückungspläne  
Parts lists  
Circuit diagrams  
Components plans



ROHDE & SCHWARZ

ÄZ Datum  
Date  
07 1184

Schaltteilliste für  
Parts list for  
ED ANSTEUERUNG  
DRIVE STAGE

Sachnummer  
Stock No.

376.9418.01 SA

Blatt  
Page

1

Kennzeichen  
Component No.

Benennung/Beschreibung  
Designation

Sachnummer  
Stock No.

enthalten in  
contained in

B1	BL SN74LS273N 8BIT-D-REG. 8BIT-D-REGISTER TEXAS SN74LS273N	BL 214.8998	
B2	BO LM124J 4XL.P.OPAMP OPERATIONAL AMPLIFIER NSC LM124J	BO 300.6353	
B3	BO LM124J 4XL.P.OPAMP OPERATIONAL AMPLIFIER NSC LM124J	BO 300.6353	
C1	CC 10NF-20+50%7X8R6000 CAPACITOR VALVO 2222 63051 64051103	CC 087.7525	
BIS/TO C5			
C6	CC 1UF +-10% 50VK1200LR CAPACITOR AEROVOX CKR06BX105KLEVELR	CC 092.1015	
BIS/TO C9			
GL4	AE BZX79/B5V6 0,5W Z-DI ZENER DIODE VALVO BZX79/B5V6	AE 012.5254	
GL6	AD 1N4448 75V 0,15A UDI DIODE VALVO 1N4448	AD 012.0700	
BIS/TO GL8			
R1	RL 0,35W 3,92KOHM+-1%TK50 RESISTOR	RL 083.1039	
R2	RL 0,35W 1,50KOHM+-1%TK50 RESISTOR DRALORIC SMA0207/1,50K-F-D	RL 083.0732	
R3	RL 0,35W 47,5 OHM+-1%TK50 RESISTOR DRALORIC SMA0207/47,5OHM-F-D	RL 082.9507	
BIS/TO R5			
R9	RL 0,35W 33,2KOHM+-1%TK50 RESISTOR DRALORIC SMA0207/33,2K-F-C	RL 083.1674	
R10	RL 0,35W 221 OHM+-1%TK50 RESISTOR DRALORIC SMA0207/2210HM-F-D	RL 083.0084	
R11	RL 0,35W 1,50KOHM+-1%TK50 RESISTOR DRALORIC SMA0207/1,50K-F-D	RL 083.0732	
R12	RL 0,35W 1KOHM+-1%TK50 RESISTOR DRALORIC SMA0207/1K-F-C	RL 082.2160	
R13	RL 0,35W20,00 OHM+-1%TK50 RESISTOR DRALORIC SMA0207/200HM-F-D	RL 082.9142	

376.9418.01 SA BL 1+

Für diese Unterlage behalten wir  
uns alle Rechte vor

Kennzeichen Component No.	Benennung/Beschreibung Designation	Sachnummer Stock No.	enthalten in contained in
R14	RL 0,35W 1,1KOHM+-1%TK50 RESISTOR DRALORIC SMA 0207/1,10K-F-C	RL 082.2483	
R6-R8	RL 0,35W 1KOHM+-1%TK50 RESISTOR DRALORIC SMA0207/1K-F-C	RL 082.2160	
ST500	FP INDIREKT. STECKERL. 36P. PIN CONNECTOR BERG 75160-102-36	FP 242.3600	
ST501	FP INDIREKT. STECKERL. 36P. PIN CONNECTOR BERG 75160-102-36	FP 242.3600	
ST502	FR JC-FASSUNG 16 POLIG 16-PIN IC-SOCKET PRECICONT US016T	FR 249.6091	
ST503	FP INDIREKT. STECKERL. 36P. PIN CONNECTOR BERG 75160-102-36	FP 242.3600	
ST504	FP INDIREKT. STECKERL. 36P. PIN CONNECTOR BERG 75160-102-36	FP 242.3600	
ST505	FP INDIREKT. STECKERL. 36P. PIN CONNECTOR BERG 75160-102-36	FP 242.3600	
T1	AK BCY59IX NPN 45V 200MA TRANSISTOR SIEMENS BCY59IX	AK 010.5163	
T2	AK BCY79IX PNP 45V 200MA TRANSISTOR SIEMENS BCY79IX	AK 010.3777	
T3	AK BCY59IX NPN 45V 200MA TRANSISTOR SIEMENS BCY59IX	AK 010.5163	
T4	AK BCY79IX PNP 45V 200MA TRANSISTOR SIEMENS BCY79IX	AK 010.3777	
T5	AK BCY59IX NPN 45V 200MA TRANSISTOR SIEMENS BCY59IX	AK 010.5163	
T6	AK BCY79IX PNP 45V 200MA TRANSISTOR SIEMENS BCY79IX	AK 010.3777	
T7	AK BCY59IX NPN 45V 200MA TRANSISTOR SIEMENS BCY59IX	AK 010.5163	
T8	AK BCY79IX PNP 45V 200MA TRANSISTOR SIEMENS BCY79IX	AK 010.3777	
T9	AK BCY59IX NPN 45V 200MA TRANSISTOR SIEMENS BCY59IX	AK 010.5163	
T10	AK BCY79IX PNP 45V 200MA TRANSISTOR SIEMENS BCY79IX	AK 010.3777	



Kennzeichen Component No.	Benennung/Beschreibung Designation	Sachnummer Stock No.	enthalten in contained in
T11	AK BCY59IX NPN 45V 200MA TRANSISTOR SIEMENS BCY59IX	AK 010.5163	
T12	AK BCY79IX PNP 45V 200MA TRANSISTOR SIEMENS BCY79IX	AK 010.3777	
T13	AK BCY59IX NPN 45V 200MA TRANSISTOR SIEMENS BCY59IX	AK 010.5163	
T14	AK BCY79IX PNP 45V 200MA TRANSISTOR SIEMENS BCY79IX	AK 010.3777	

 Für diese Unterlage behalten wir  
 uns alle Rechte vor

Name	
Datum	
And. Mittg. Nr.	
And. zust.	
Name	
Datum	
And. Mittg. Nr.	
And. zust.	

Diese Zeichnung ist unser Eigentum. Vervielfältigung, unbefugte Verwertung, Mitteilung an andere ist strafbar und schadenersatzpflichtig.

ROHDE & SCHWARZ MÜNCHEN

Name	
Datum	
And. Mittg. Nr.	
And. zust.	
Name	
Datum	
gezeichnet	
bearbeitet	
geprüft	
normgepr.	

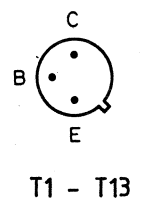
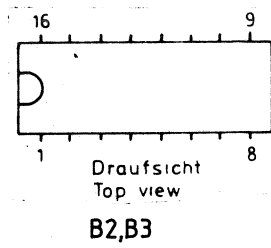
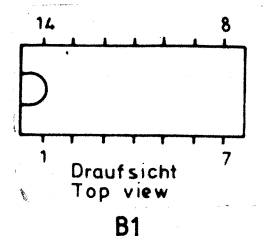
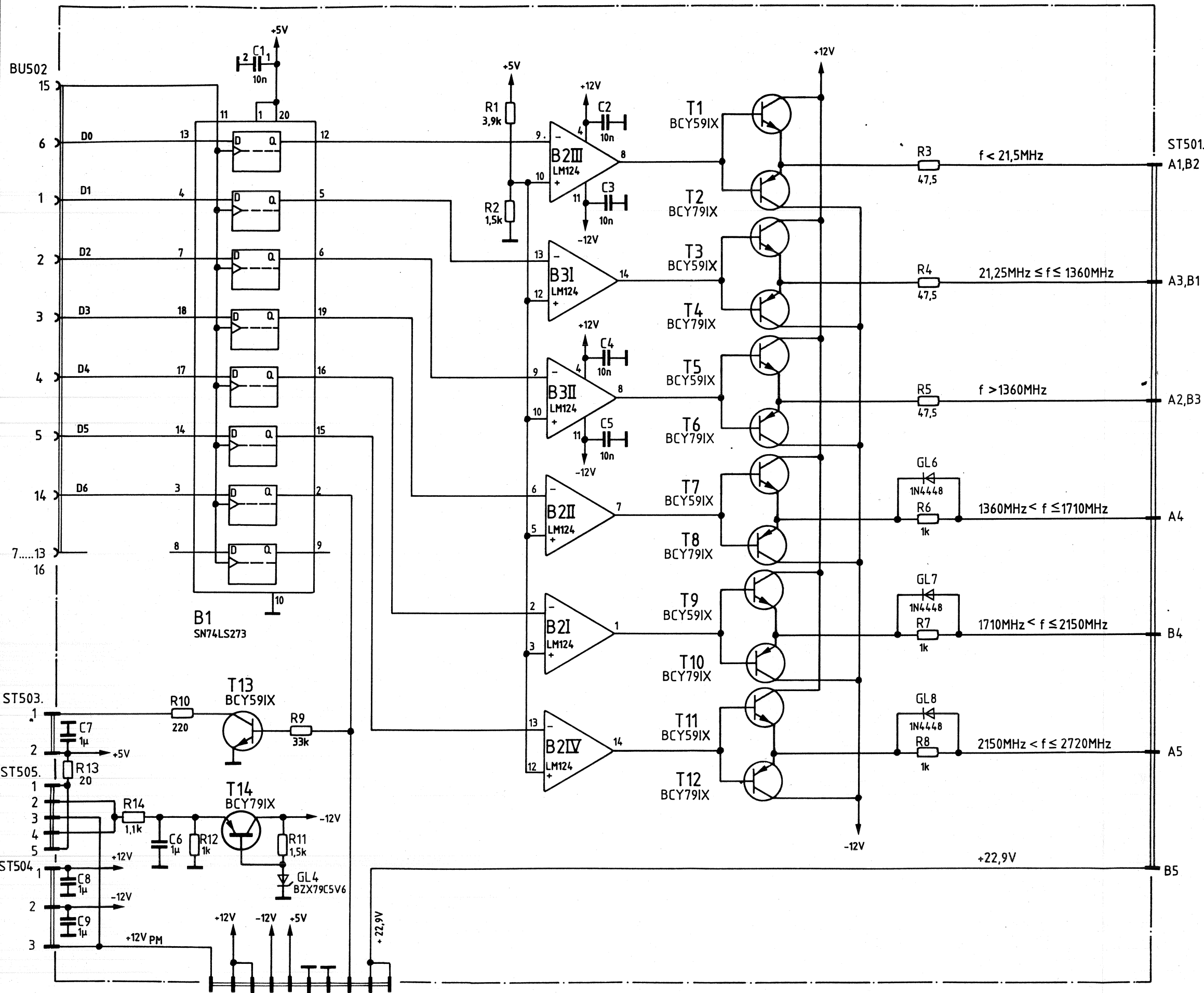

Stromlauf gilt für VAR 02  
Circuit diagram is valid for model 02

	Stromlauf zu	Zeichn. Nr. <b>376.9418 S</b>
	<b>Ansteuerung / Drive stage</b>	reg. i.V. 376.8011 V erste Z.





**ROHDE & SCHWARZ**

SERVICE INSTRUCTIONS

Diode Switch I

914.9303.02 (Y101)

Printed in West Germany

Table of Contents

		Page
<u>5</u>	<u>Service Instructions for Diode Switch I</u>	
	<u>914.9303.02 (Y101)</u> .....	5.1
5.1	Functional Description .....	5.1
5.2	Checking the Diode Switch I .....	5.1
5.3	Interfaces .....	5.2

5.1 Functional Description

The signal from the output amplifier Y20 can be switched selectively for the mixer, SMPD output or the frequency doubler.

5.2 Checking the Diode Switch I

Check transmission loss according to Table 5-1.  
 Maximum value: 1.5 dB  
 Minimum value of isolation for switched-off channel: 40 dB

Table 5-1

U <sub>1</sub>	U <sub>2</sub>	U <sub>3</sub>	Frequency range ±1 Hz	on channel	off channel
∅	∅	1	135.005 < f < 156.25 MHz	E → A3	E→A1, E→A2
∅	1	∅	21.25 < f < 1360 MHz	E → A2	E→A1, E→A3
1	∅	∅	680 < f < 1360 MHz	E → A1	E→A2, E→A3

1 ≙ -11 V ±0.5 V  
 ∅ ≙ +10 V ±0.5 V







**ROHDE & SCHWARZ**

SERVICE INSTRUCTIONS

Diode Switch II

914.9403 (Y102)

Printed in West Germany

# Table of Contents

		Page
<u>5</u>	<u>Service Instructions for Diode Switch II</u>	
	<u>914.9403 (Y102) .....</u>	5.1
5.1	Functional Description .....	5.1
5.2	Checking the Diode Switch II .....	5.1
5.3	Interfaces .....	5.2

### 5.1 Functional Description

The signal from the output amplifier (Y20) or the output signal of the frequency doubler can be switched selectively with the aid of Y102 to the input of the output stage III (Y15).

### 5.2 Checking the Diode Switch II.

Check the transmission loss according to Table 5-1.

Maximum value: 1.5 dB

Check isolation according to Table 5-1.

Minimum value: 40 dB

Table 5-1

U <sub>1</sub>	U <sub>2</sub>	U <sub>3</sub>	Frequency range $\pm 1$ Hz	on-channel	off-channel
1	∅	∅	$21.25 < f < 1360$ MHz	E1 → A	E2 → A
∅	1	∅	$1360 < f < 2720$ MHz	E2 → A	E1 → A
∅	∅	1	-	-	E1 → A, E2 → A

1  $\hat{=}$  -11 V  $\pm 0.5$  V

∅  $\hat{=}$  +10 V  $\pm 0.5$  V

### 5.3 Interfaces

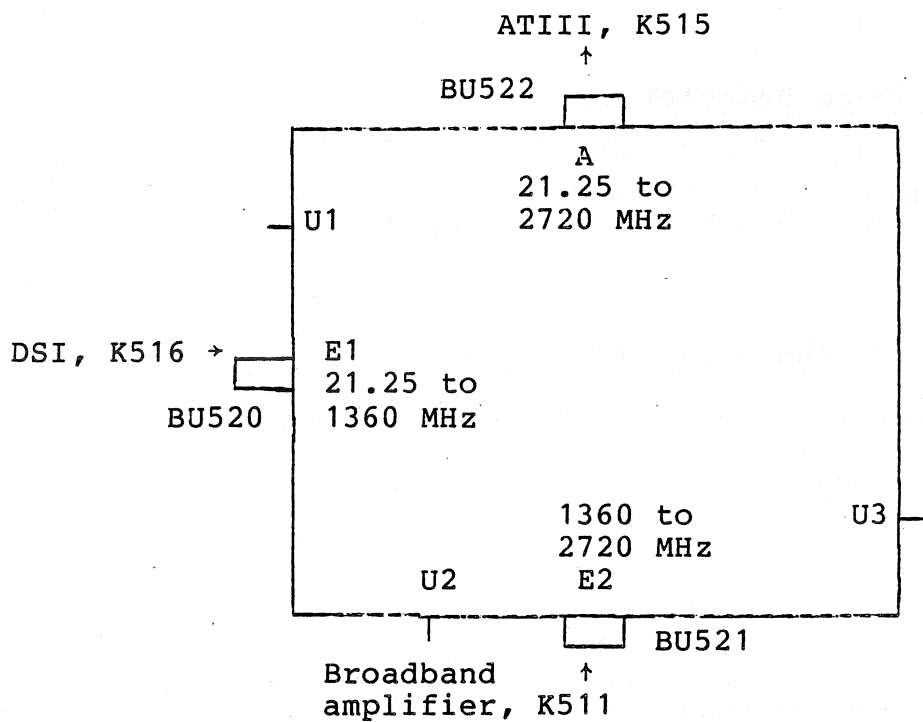

BU	520 [E1]	521 [E2]	522 [A]
f *) [MHz]	21.25 < f < 1360	1360 to 2720	21.25 < f < 2720
Level	20.5 to 22.5 dBm	20.5 to 22.5 dBm	19 to 21 dBm
R <sub>i</sub>	50 Ω	50 Ω	50 Ω
AC-DC	AC	AC	AC
Type of curve	sinusoidal	sinusoidal	sinusoidal

\*) referred to 1 Hz resolution

Terminal	U [V <sub>dc</sub> ]
U1	+10 <sup>±0.5</sup> / -11 <sup>±0.5</sup>
U2	+10 <sup>±0.5</sup> / -11 <sup>±0.5</sup>
U3	+10 <sup>±0.5</sup> / -11 <sup>±0.5</sup>



**ROHDE & SCHWARZ**

SERVICE INSTRUCTIONS

Broadband Amplifier

376.9199 (Y103)

Printed in West Germany

# Table of Contents

		Page
<u>5</u>	<u>Service Instructions Broadband Amplifier</u>	
	<u>376.9199 (Y103) .....</u>	<u>5.1</u>
5.1	Functional Description .....	5.1
5.2	Checking and Adjustment .....	5.1
5.2.1	Checking the Frequency Response .....	5.1
5.2.2	Checking the Harmonics .....	5.2
5.2.3	Checking the Broadband Noise Level .....	5.2
5.3	Troubleshooting .....	5.2
5.3.1	Interfaces .....	5.2
	Parts list	
	Circuit diagram	
	Components location plans	

### 5.1 Functional Description

(See circuit diagram 376.9199 S)

Y103 consists of three amplifying stages (T13, T14, T15) whose operating points are controlled by transistors T3, T6 and T10. Transistor T3 controls the current flow through the RF transistor T15 via its base in a way that the potential difference across the load (R5, R6) is made to equal the nominal value given by the voltage divider R1/R2. GL2 compensates for temperature variation. The RF transistor has in addition an overload protection circuitry made up of T1 and T4.

### 5.2 Checking and Adjustment

#### 5.2.1 Checking the Frequency Response

Test setup:

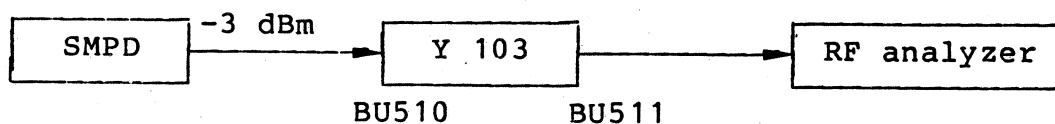

The typical gain/frequency response curve together with spread of values is presented in Fig. 5-1.

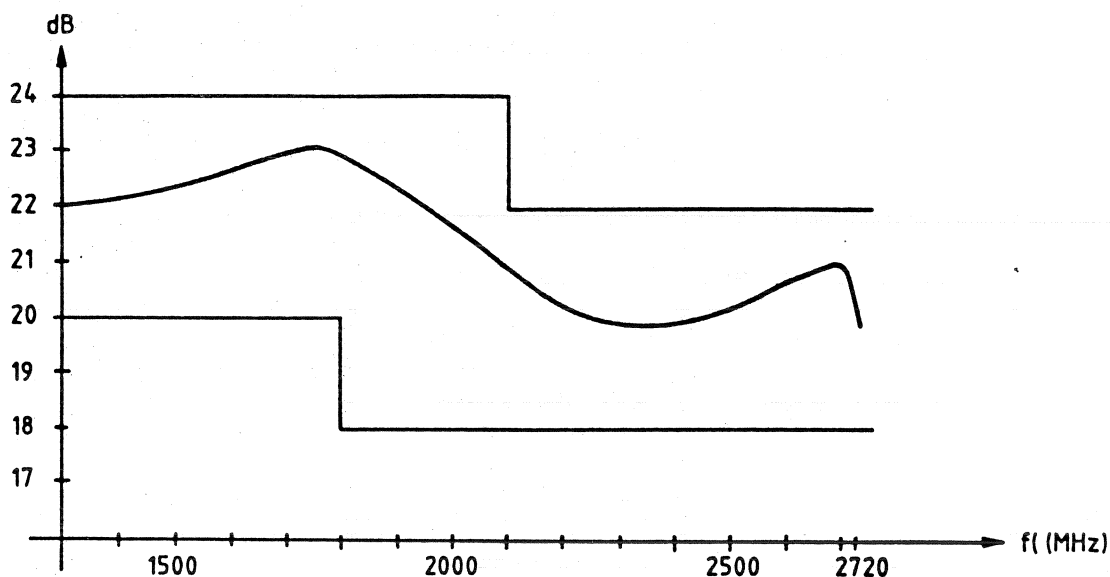

Fig. 5-1 Typical frequency response curve with tolerance limits



### 5.2.2 Checking the Harmonics

Use setup as per 5.2.1. Measure harmonics using RF analyzer at BU511. Depending on the measured frequency response, adjust the input power to produce an output power of +22 dBm. Harmonic levels of -27 dBc up to 1500 MHz and of -30 dBc above 1500 MHz must not be exceeded.

### 5.2.3 Checking the Broadband Noise Level

Terminate input (BU510) with 50  $\Omega$ . Connect up spectrum analyzer to output (BU511). The noise power measured with respect to 1 Hz bandwidth should not exceed -130 dBm.

## 5.3 Troubleshooting

With no signal applied, T13 and T14 should have a collector voltage of  $19 \pm 0.5$  V, whereas T15 a collector voltage of  $18.3 \pm 0.5$  V.

### 5.3.1 Interfaces

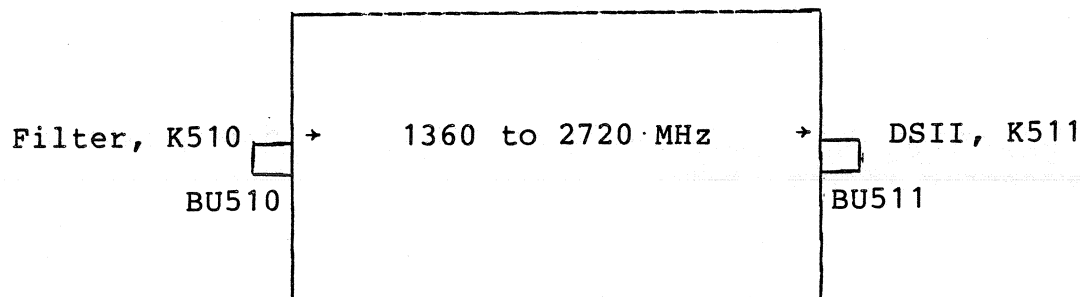

BU	510	511
f	1360 to 2720 MHz	1360 to 2720 MHz
Level	2 to 5 dBm	20 to 23 dBm
R <sub>i</sub>	not defined	not defined, load 50 $\Omega$
AC-DC	AC	Ac
Shape of curve	Sinusoidal	Sinusoidal



ROHDE & SCHWARZ  
MÜNCHEN

Schalteillisten  
Stromläufe  
Bestückungspläne  
Parts lists  
Circuit diagrams  
Components plans



REIBERSCHEIN

01 0985

Schaltliste für  
Passivlöter

BREITBANDVERSTAERKER

Sachnummer  
Gsch.Nr.

376.9199.01 SA

Blatt  
Page

1

Kennzeichen Component No.	Benennung/Bezeichnung Designation	Sachnummer Stock No.	enthalten in contained in
BU510	FJ EINBAUBUCHSE SYST.SMA HF CONNECTOR RADIALL R125.403	FJ 467.7946	
BU511	FJ EINBAUBUCHSE SYST.SMA HF CONNECTOR RADIALL R125.403	FJ 467.7946	
C1	CE 100NF+-20%35V 5X 4X 7 ELECTROLYTIC CAPACITOR ERO-TANTAL TA-ELKOETR1-0,1/35	CE 022.8156	376.9218.01
C2	CE 100NF+-20%35V 5X 4X 7 ELECTROLYTIC CAPACITOR ERO-TANTAL TA-ELKOETR1-0,1/35	CE 022.8156	376.9218.01
C3	CE 100NF+-20%35V 5X 4X 7 ELECTROLYTIC CAPACITOR ERO-TANTAL TA-ELKOETR1-0,1/35	CE 022.8156	376.9218.01
C5	CC 6,8PF+-0,5PF50V1NPO CAPACITOR VITRAMON VJ0805A6R8CFA	CC 093.2167	376.9218.01
C6	CC 1,5NF-20+80%R10000TRAP CAPACITOR STETTNER TEFK7,1500/2080E9000	CC 082.1712	376.9218.01
C7	CC 1,5NF-20+80%R10000TRAP CAPACITOR STETTNER TEFK7,1500/2080E9000	CC 082.1712	376.9218.01
C9	CC 2,1PF+-0,25PF50V2NPO CAPACITOR VITRAMON VJ0805A2R1CFA	CC 093.5550	376.9218.01
C10	CC 1,5NF-20+80%R10000TRAP CAPACITOR STETTNER TEFK7,1500/2080E9000	CC 082.1712	376.9218.01
C11	CC 1,5NF-20+80%R10000TRAP CAPACITOR STETTNER TEFK7,1500/2080E9000	CC 082.1712	376.9218.01
C13	CC 1,5PF+-0,25PF50VNPO CH CHIP CAPACITOR VITRAMON VJ0805A1R5CFA	CC 099.6793	376.9218.01
C14	CC 1,5NF-20+80%R10000TRAP CAPACITOR STETTNER TEFK7,1500/2080E9000	CC 082.1712	376.9218.01
C15	CC 1,5NF-20+80%R10000TRAP CAPACITOR STETTNER TEFK7,1500/2080E9000	CC 082.1712	376.9218.01
C16	CC 15PF+-10%100V3NPO CHIP CAPACITOR VITRAMON VJ1005A150KFB	CC 082.3009	376.9218.01
D1	LD 10GHZ 50DB100V10A4PDX9 LEAD THROUGH FILTER ERIE R&S-ZCHNG.451.4636	LD 451.4636	
GL2	AD 1N4151 50V 0,2 A UDI DIODE AEG-TELEF 1N4151	AD 012.0723	376.9218.01

Für diese Unterlage behalten wir  
uns alle Rechte vor

Kennzeichen Component No.	Benennung/Beschreibung Designation	Sachnummer Stock No.	enthalt in contained in
GL5	AD 1N4151 50V 0,2 A UDI DIODE	AD 012.0723	376.9218.01
GL9	AEG-TELEF 1N4151 AD 1N4151 50V 0,2 A UDI DIODE AEG-TELEF 1N4151	AD 012.0723	376.9218.01
L1 BIS/TO L6	SPULE	377.0520	376.9218.01
R1	RL 0,35W 1,21KOHM+-1%TK50 RESISTOR	RL 083.0655	376.9218.01
R2	DRALORIC SMA0207/1,21K-F-D RL 0,35W 18,2KOHM+-1%TK50 RESISTOR	RL 083.1480	376.9218.01
R3	DRALORIC SMA/207/18,2K-F-C RL 0,35W 562 OHM+-1%TK50 RESISTOR	RL 083.0461	376.9218.01
R4	DRALORIC SMA0207/562OHM-F-D RL 0,35W 1,50KOHM+-1%TK50 RESISTOR	RL 083.0732	376.9218.01
R5	DRALORIC SMA0207/1,50K-F-D RL 0,35W 20,00 OHM+-1%TK50 RESISTOR	RL 082.9142	376.9218.01
R6	DRALORIC SMA0207/200HM-F-D RL 0,35W 20,00 OHM+-1%TK50 RESISTOR	RL 082.9142	376.9218.01
R7	DRALORIC SMA0207/200HM-F-D RL 0,35W 100 OHM+-1%TK50 DEPOS.-CARBON RESISTOR	RL 082.6543	376.9218.01
R8	DRALORIC SMA0207/100/HM-F-D RL 0,35W 100 OHM+-1%TK50 DEPOS.-CARBON RESISTOR	RL 082.6543	376.9218.01
R9	DRALORIC SMA0207/100/HM-F-D RL 0,35W 4,75KOHM+-1%TK50 RESISTOR	RL 083.1097	376.9218.01
R10	DRALORIC SMA0207/4,75K-F-D RL 0,35W 47,5KOHM+-1%TK50 RESISTOR	RL 083.1800	376.9218.01
R11	DRALORIC SMA/207/47,5K-F-C RL 0,35W 1,21KOHM+-1%TK50 RESISTOR	RL 083.0655	376.9218.01
R12	DRALORIC SMA0207/1,21K-F-D RL 0,35W 24,3KOHM+-1%TK50 RESISTOR	RL 083.1574	376.9218.01
R13	DRALORIC SMA/207/24,3K-F-C RL 0,35W 825 OHM+-1%TK50 RESISTOR	RL 082.2502	376.9218.01
R14	DRALORIC SMA 0207/825OHM-F-C RL 0,35W 1,50KOHM+-1%TK50 RESISTOR	RL 083.0732	376.9218.01
R15	DRALORIC SMA0207/1,50K-F-D RL 0,35W 20,00 OHM+-1%TK50 RESISTOR	RL 082.9142	376.9218.01
	DRALORIC SMA0207/200HM-F-D		

tous droits réservés



RECHENSCHEIN

01 0985

BREITBANDVERSTAERKER

Sachnummer  
Stock No.

376.9199.01 SA

Blatt  
Page

3

Kennzeichen Component No.	Benennung/Beschreibung Designation	Sachnummer Stock No.	enthalt in continued in
R16	RL 0,35W20,00 OHM+-1%TK50 RESISTOR DRALORIC SMA0207/200HM-F-D	RL 082.9142	376.9218.01
R17	RL 0,35W 100 OHM+-1%TK50 DEPOS.-CARBON RESISTOR DRALORIC SMA0207/100/HM-F-D	RL 082.6543	376.9218.01
R18	RL 0,35W 100 OHM+-1%TK50 DEPOS.-CARBON RESISTOR DRALORIC SMA0207/100/HM-F-D	RL 082.6543	376.9218.01
R19	RL 0,35W 4,75KOHM+-1%TK50 RESISTOR DRALORIC SMA0207/4,75K-F-D	RL 083.1097	376.9218.01
R20	RL 0,35W 47,5KOHM+-1%TK50 RESISTOR DRALORIC SMA/207/47,5K-F-C	RL 083.1800	376.9218.01
R21	RL 0,35W 1,21KOHM+-1%TK50 RESISTOR DRALORIC SMA0207/1,21K-F-D	RL 083.0655	376.9218.01
R22	RL 0,35W 24,3KOHM+-1%TK50 RESISTOR DRALORIC SMA/207/24,3K-F-C	RL 083.1574	376.9218.01
R23	RL 0,35W 825 OHM+-1%TK50 RESISTOR DRALORIC SMA 0207/825OHM-F-C	RL 082.2502	376.9218.01
R24	RL 0,35W 1,50KOHM+-1%TK50 RESISTOR DRALORIC SMA0207/1,50K-F-D	RL 083.0732	376.9218.01
R25	RL 0,35W20,00 OHM+-1%TK50 RESISTOR DRALORIC SMA0207/200HM-F-D	RL 082.9142	376.9218.01
R26	RL 0,35W20,00 OHM+-1%TK50 RESISTOR DRALORIC SMA0207/200HM-F-D	RL 082.9142	376.9218.01
R27	RL 0,35W 100 OHM+-1%TK50 DEPOS.-CARBON RESISTOR DRALORIC SMA0207/100/HM-F-D	RL 082.6543	376.9218.01
R28	RL 0,35W 100 OHM+-1%TK50 DEPOS.-CARBON RESISTOR DRALORIC SMA0207/100/HM-F-D	RL 082.6543	376.9218.01
R29	RL 0,35W 4,75KOHM+-1%TK50 RESISTOR DRALORIC SMA0207/4,75K-F-D	RL 083.1097	376.9218.01
R30	RL 0,35W 47,5KOHM+-1%TK50 RESISTOR DRALORIC SMA/207/47,5K-F-C	RL 083.1800	376.9218.01
R31	RL 0,35W 2,21KOHM+-1%TK50 RESISTOR DRALORIC SMA 0207/2,21K-F-C	RL 082.2477	376.9218.01
R32	RD 1,2W 22 OHM+-3% WIRE WOUND RESISTOR SAGE 1000S/220HM/3%	RD 067.0583	376.9218.01
R34	RL 0,35W 2,21KOHM+-1%TK50 RESISTOR DRALORIC SMA 0207/2,21K-F-C	RL 082.2477	376.9218.01
R35	RD 1,2W 22 OHM+-3% WIRE WOUND RESISTOR SAGE 1000S/220HM/3%	RD 067.0583	376.9218.01

376.9199.01 SA BL 3+

Für diese Unterlage behalten wir  
uns alle Rechte vor



RECHENBREMSE

AZ Datum  
Date  
01 0985

Bestellliste für  
Parts list for  
BREITBANDVERSTAERKER

Sachnummer  
Stock No.  
376.9199.01 SA

Blatt  
Page  
4

Kennzeichen Component No.	Benennung/Bezeichnung Designation	Sachnummer Stock No.	enthalten in contained in
R37	RL 0,35W 2,21KOHM+-1%TK50 RESISTOR DRALORIC	RL 082.2477	376.9218.01
R38	SMA 0207/2,21K-F-C RD 1,2W 22 OHM+-3% WIRE WOUND RESISTOR SAGE	RD 067.0583	376.9218.01
V1	PNP 45V 200MA AK BCY79IX TRANSISTOR SIEMENS	AK 010.3777	376.9218.01
V3	PNP 45V 200MA AK BCY79IX TRANSISTOR SIEMENS	AK 010.3777	376.9218.01
V4	BCY79IX AK 2N2222A NPN 40V 800MA TRANSISTOR VALVO	AK 010.5405	376.9218.01
V6	2N2222A AK BCY79IX PNP 45V 200MA TRANSISTOR SIEMENS	AK 010.3777	376.9218.01
V7	BCY79IX AK BCY79IX PNP 45V 200MA TRANSISTOR SIEMENS	AK 010.3777	376.9218.01
V8	BCY79IX AK 2N2222A NPN 40V 800MA TRANSISTOR VALVO	AK 010.5405	376.9218.01
V10	2N2222A AK BCY79IX PNP 45V 200MA TRANSISTOR SIEMENS	AK 010.3777	376.9218.01
V11	BCY79IX AK BCY79IX PNP 45V 200MA TRANSISTOR SIEMENS	AK 010.3777	376.9218.01
V12	BCY79IX AK 2N2222A NPN 40V 800MA TRANSISTOR VALVO	AK 010.5405	376.9218.01
V13	2N2222A BD TRANS.ENDSTUFE FINAL STAGE	376.9299	376.9218.01
V14	BD TRANS.ENDSTUFE FINAL STAGE	376.9299	376.9218.01
V15	BD TRANS.ENDSTUFE FINAL STAGE	376.9299	376.9218.01

- ENDE -

uns alle Rechte vor

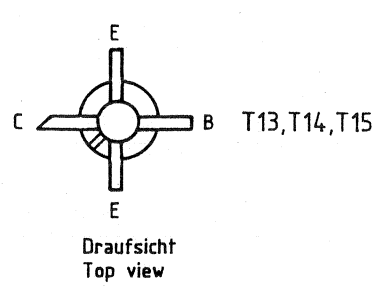
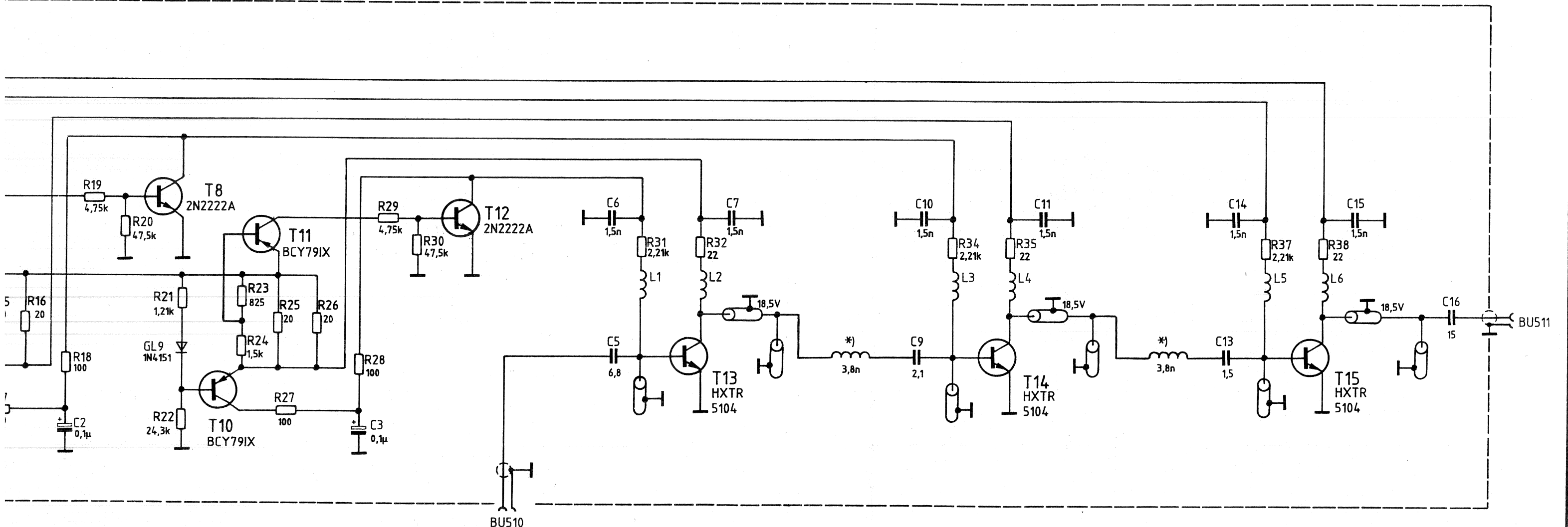

\*) gedrucktes Bauteil  
printed component

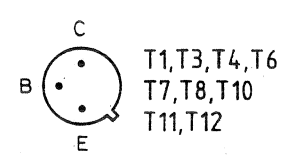

Stromlauf gilt für VAR 02  
Circuit diagram is valid for model 02

	Stromlauf zu		Breitbandverstärker 1,36-2,72GHz Broadband amplifier		Z	Zeichn.-Nr.	376.9199 S	Blatt-Nr.
	SMPD	reg. i. V.	376.8011 V	erste Z.		376.8011		v



	Name
	Datum
	Ang. Mittig Nr.
	zust.
	Name
	Datum
	Ang. Mittig Nr.
	zust.

wir uns alle Rechte vor.



	Name
	Datum
	Nr.
	zust.
	Name
	um
	12.85
	12.85
	geprüft
	normgepr.
	gezeichnet
	GU
	bearbeitet
	Ho
	IKGA

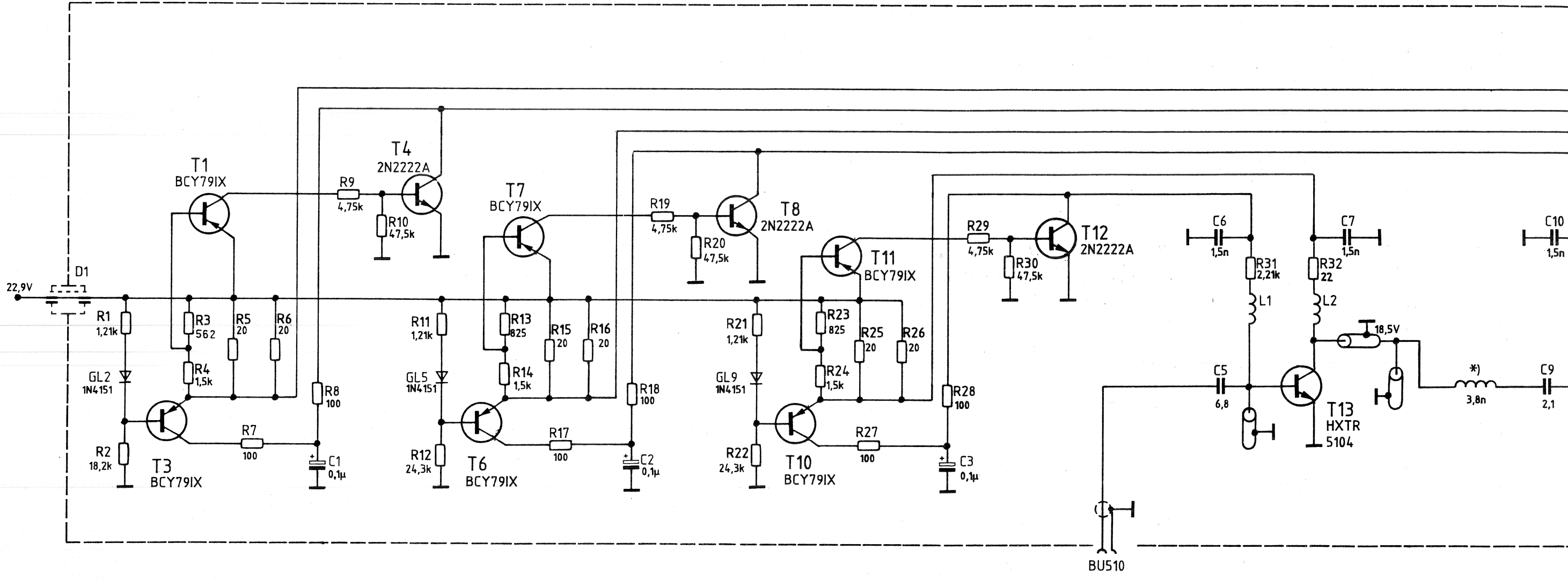

Ansicht und Leitungsführung Bauteilseite  
View of tracks on component side

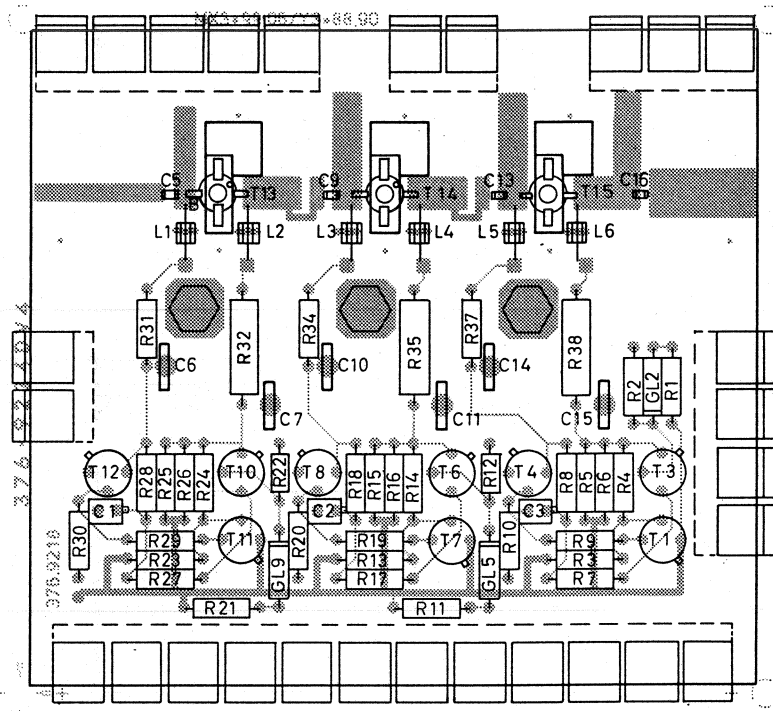

Ansicht und Leitungsführung Lötseite  
View of tracks on solder side

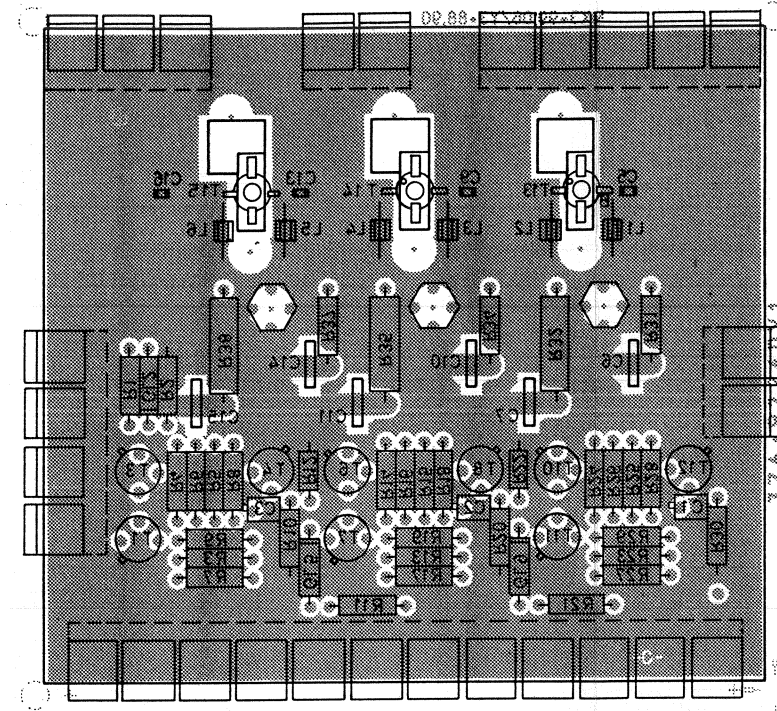

Für diese Unterlage behalten wir uns alle Rechte vor.

B	31459	5.84	C0	Maße ohne Toleranzangabe	Maßstab 1 : 1	
					Halbzeug Werkstoff	
				1KGA Tag Name	Benennung	Z
				Bearb. 5.84 C0	Breitbandverstärker Broadband amplifier	
				Gepr		
				Norm		
				<b>ROHDE &amp; SCHWARZ</b>	Zeichn.-Nr	Blatt-Nr
					376.9218	2
And	Anderungs-	Tag	Name	zu Gerät SMPD	reg. Nr 376.8011V	v B
Just	Mitteilung				erste 376.8011	



**ROHDE & SCHWARZ**

SERVICE INSTRUCTIONS

Filter

914.9503 (Y104)

Printed in West Germany

# Table of Contents

		Page
<u>5</u>	<u>Service Instructions for the Filter</u>	
	<u>914.9503 (Y104) .....</u>	5.1
5.1	Functional Description .....	5.1
5.2	Checking the Filter .....	5.1
5.3	Interfaces .....	5.2

### 5.1 Functional Description

The filter (Y104) contains three switchable bandpass filters for the suppression of subharmonics and higher harmonics of the spectrum generated in the frequency doubler. The control of the diode switches in front and following the bandpass filters is achieved by Y100.

### 5.2 Checking the Filter

Connect sweep generator to input, RF analyzer to output of the filter (Y104) and set output level to +5 dBm. To switch on the filter to be checked, set on the SMPD a frequency between  $f_1$  and  $f_u$ . Display filter curve on analyzer.

Table 5-1 Nominal filter curve

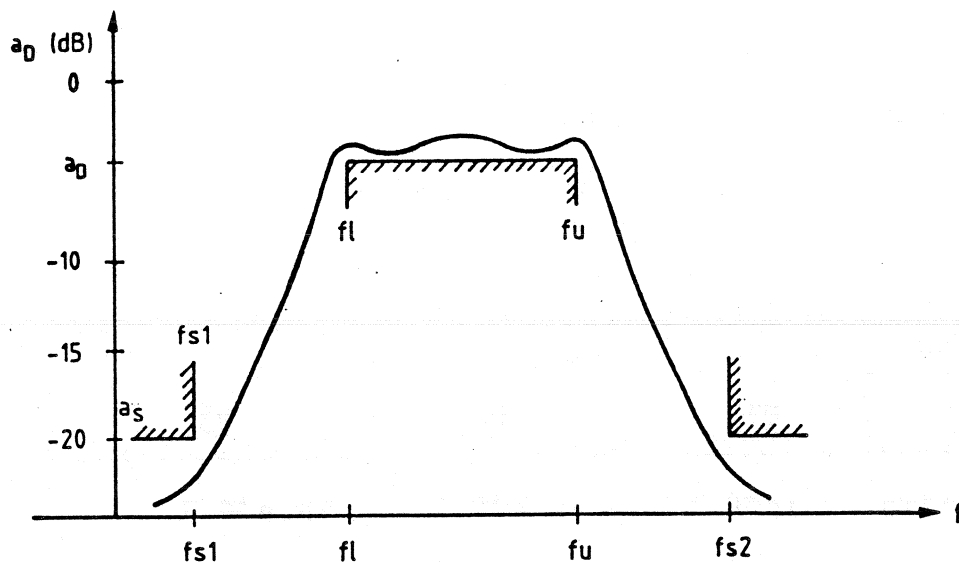

Filter	$f_{s1}$ [MHz]	$f_l$ [MHz]	$f_u$ [MHz]	$f_{s2}$ [MHz]	$a_D$ [dB]	$a_s$ [dB]
1	855	1360	1710	2040	-4	-20
2	1075	1710	2150	2565	-4	-20
3	1360	2150	2720	3225	-4	-20

### 5.3 Interfaces

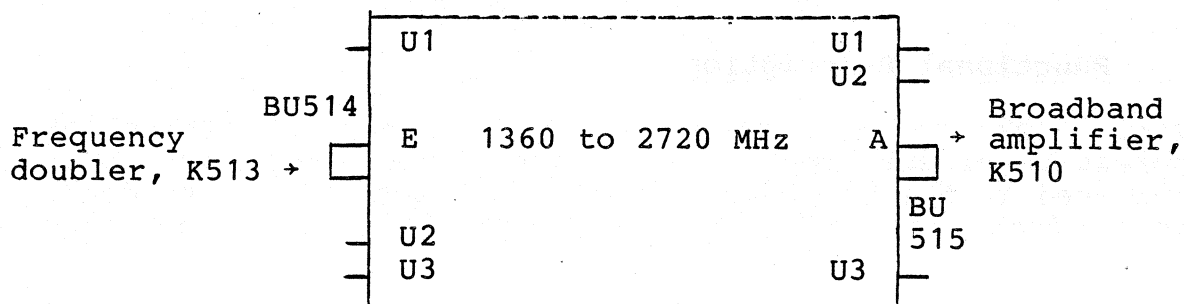

BU	514 [E]	515 [A]
f	1360 to 2720 MHz	1360 to 2720 MHz
Level	6.5 to 8.5 dBm	2.5 to 4.5 dBm
R <sub>i</sub>	50 Ω	50 Ω
AC-DC	AC	AC
Shape of curve	Sinusoidal	Sinusoidal

Filter switched on	Bandpass [MHz]	Voltage [V] at		
		U1	U2	U3
1	1360 to 1710	-10 <sup>±0.5</sup>	+0.8 <sup>±0.1</sup>	+0.8 <sup>±0.1</sup>
2	1710 to 2150	+0.8 <sup>±0.1</sup>	-10 <sup>±0.5</sup>	+0.8 <sup>±0.1</sup>
3	2150 to 2720	+0.8 <sup>±0.1</sup>	+0.8 <sup>±0.1</sup>	-10 <sup>±0.5</sup>



**ROHDE & SCHWARZ**

SERVICE INSTRUCTIONS

Frequency Doubler

376.9501 (Y105)

Printed in West Germany



# Table of Contents

		Page
<u>5</u>	<u>Service Instructions for Frequency Doubler</u>	
	<u>376.9501 (Y105)</u> .....	5.1
5.1	Functional Description .....	5.1
5.2	Checking the Frequency Doubler .....	5.1
5.3	Interfaces .....	5.1

Parts list  
Circuit diagram  
Components location plans

**5**                    **Service Instructions for Frequency Doubler**  
**376.9501 (Y105)**

**5.1**                    **Functional Description**

Y105 contains a passive frequency doubler which converts the input signal to a frequency double that of the input frequency at a conversion loss of about 10 dB. A 3-dB attenuator is connected ahead of the doubler.

**5.2**                    **Checking the Frequency Doubler**

Feed in at the input a +19-dBm signal at 680 to 1360 MHz. Connect RF analyzer to the output and measure the level of the signal doubled in frequency. Minimum value: +5 dBm.

**5.3**                    **Interfaces**

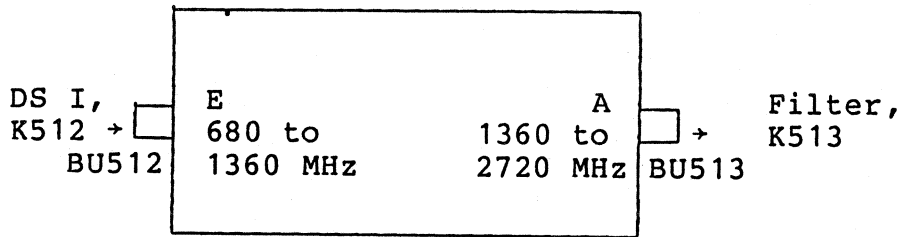

BU	512                    [E]	513                    [A]
f	680 to 1360 MHz	1360 to 2720 MHz
Level	20.5 to 22.5 dBm	6.5 to 8.5 dBm
R <sub>i</sub>	50 Ω	50 Ω
AC-DC	AC	AC



ROHDE & SCHWARZ  
MÜNCHEN

Schalteillisten  
Stromläufe  
Bestückungspläne  
Parts lists  
Circuit diagrams  
Components plans



RONDELEGGEMARZ

AZ Datum  
Date  
03 1185

Schaltteilleiste für  
Parts list for  
VERDOPPLER  
DOUBLER

Sachnummer  
Stock No.  
376.9501.01 SA

Blatt-  
Page  
1

Kennzeichen Component No.	Benennung/Beschreibung Designation	Sachnummer Stock No.	enthalten in contained in
N1	ES BREITB.FREQU.VERDOPPLE ANZAC FM-104	376.9553	376.9518.01
R1	RF 0,05W331,5 OHM+-1% RESISTOR	178.5230	376.9518.01
R2	RESISTA WFS22/331,5/1/0,05 RF 0,05W331,5 OHM+-1% RESISTOR	178.5230	376.9518.01
R3	RESISTA WFS22/331,5/1/0,05 RF 0,05W 14,01 OHM+-1% RESISTOR RESISTA WFS22/14,01/1/0,05	030.0538	376.9518.01
ST512	FJ EINBAUBUCHSEN SYST.SMA CONNECTOR SMA SUHNER 235SMA-50-0-22	376.9699	
ST513	FJ EINBAUBUCHSEN SYST.SMA CONNECTOR SMA SUHNER 235SMA-50-0-22	376.9699	

- ENDE -

Für diese Unterlage behalten wir  
uns alle Rechte vor

Für diese Unterlage behalten wir uns alle Rechte vor

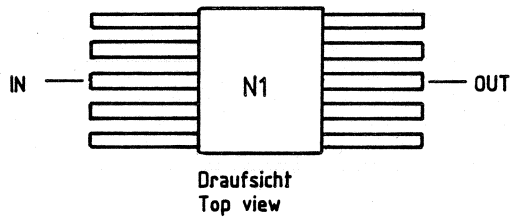
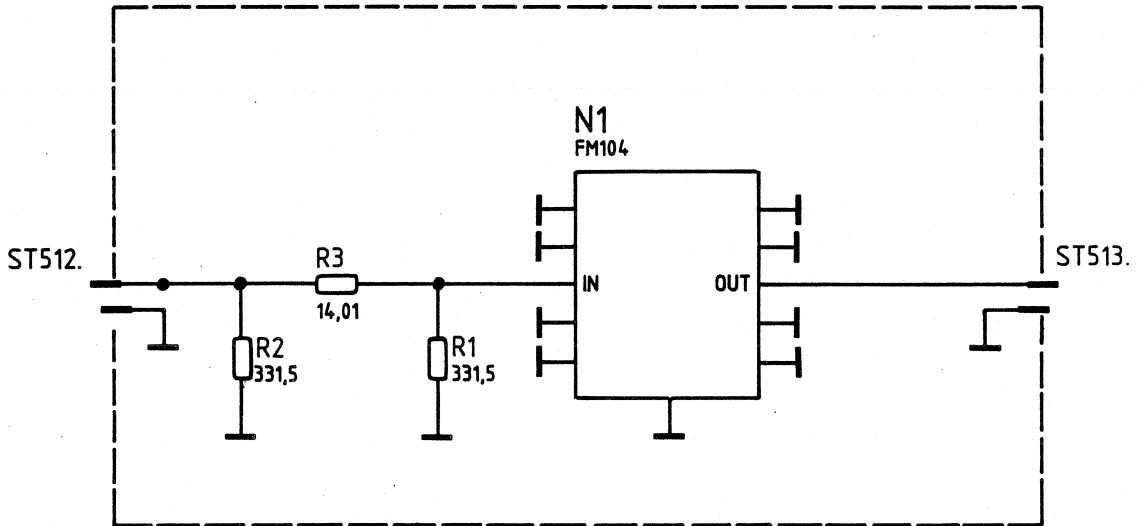

				1KGA	Tag	Name	Benennung  Verdoppler / Doubler		
				Bearb.	2.84	CO			
				Gepr.					
				Norm					
							Zeichn.-Nr.	376.9501 S	Blatt-Nr.
							zu Gerät		SMPD
Änd. Zust.	Änderungs-Mitteilung	Tag	Name				v	Bl	

Ansicht und Leitungsführung Bauteilseite  
View of tracks on component side

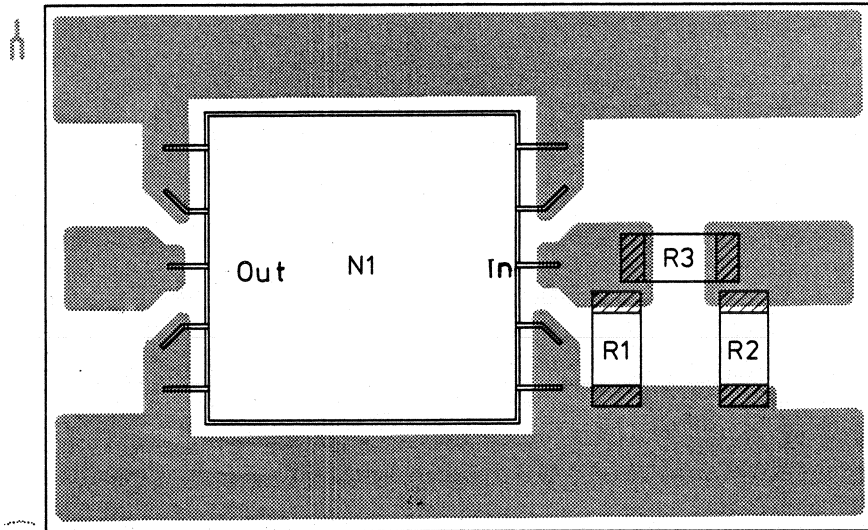

Ansicht und Leitungsführung Lötseite  
View of tracks on solder side

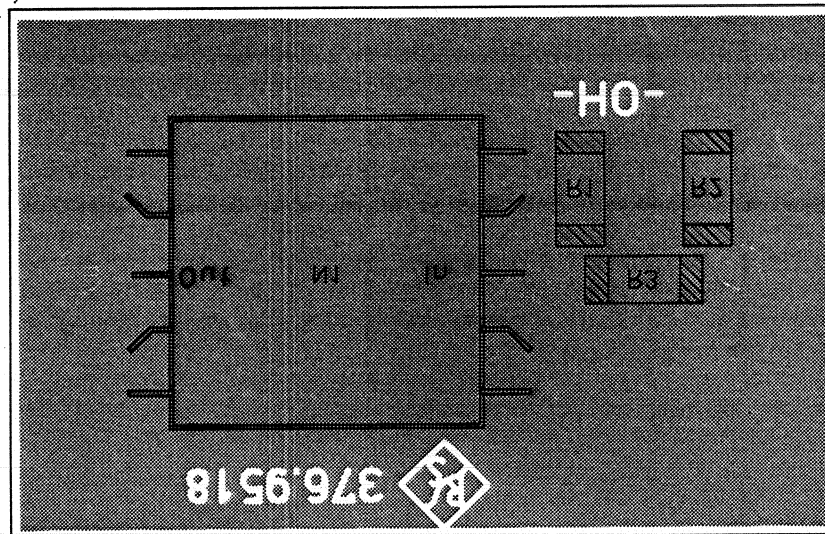

Für diese Unterlage behalten wir uns alle Rechte vor.

				Maße ohne Toleranzangabe		Maßstab 2.5 : 1				
						Halbzeug, Werkstoff				
				1KGA	Tag	Name		Benennung		
				Bearb.	12.83			Verdoppler Doublers		
				Gepr.						Z
				Norm						
						Zeichn.-Nr.		Blatt-Nr.		
						376.9518		2		
Änd. Zust.	Änderungs-Mitteilung	Tag	Name	zu Gerät SMPD		reg. i. V. 376.8011 V		erste Z. 376.8011		
								v Bl		



**ROHDE & SCHWARZ**

SERVICE INSTRUCTIONS

Pulse Modulator Option

SMPD-B1 377.0914

Printed in West Germany



# Table of Contents

	Page	
<u>5</u>	<u>Service Instructions for Pulse Modulator</u>	
	<u>Option SMPD-B1 377.0914</u> .....	5.1
5.1	Functional Description .....	5.1
5.2	Checking the Pulse Modulator .....	5.1
5.2.1	Checking the Transmission Loss and Isolation .	5.1
5.2.2	Checking the Rise and Fall Times .....	5.2
5.3	Interfaces .....	5.2
5.4	Retrofitting the Pulse Modulator Option .....	5.3
	Parts list	
	Circuit diagram	
	Components location plan	

### 5.1 Functional Description

The SMPD-B1 option affords the pulse modulation of the SMPD output signal with the aid of an external control signal. The option consists of two RF relays and a PIN diode switch with an integrated driver, and is incorporated between the output section III and the attenuator. In the unmodulated mode, the modulator is bypassed by means of the RF relays which are switched over by activating the PM key (49) or using the IEC-bus command U1 cutting in the modulator in the signal path. Activating the key 49 or entering the IEC-bus command U0 again causes the pulse modulator to be switched off.

### 5.2 Checking the Pulse Modulator

#### 5.2.1 Checking the Transmission Loss and Isolation

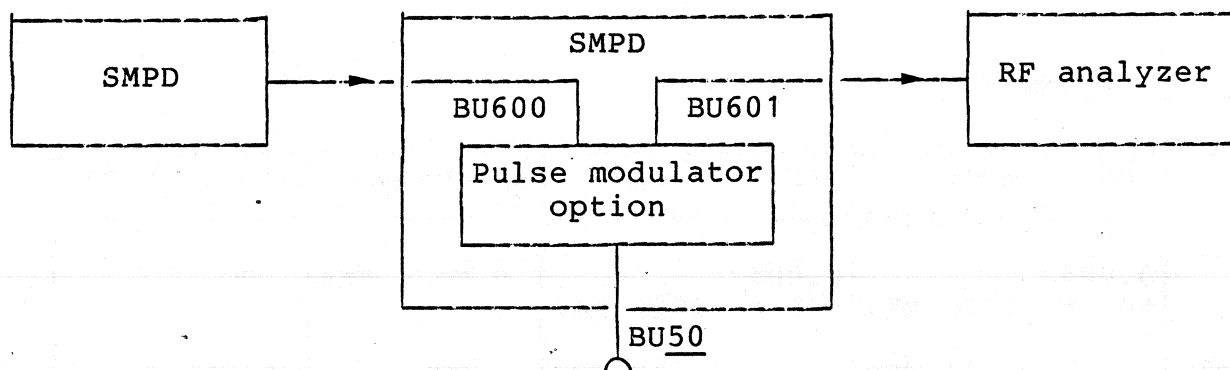

Setting of the SMPD source: +13 dBm, 500 to 2720 MHz

Select pulse modulation and apply a TTL high signal to BU50 to enable the low loss state of the pulse modulator.

Maximum transmission loss: 2.5 dB

Switch pulse modulator to high loss state by applying a TTL low signal to BU50.

Minimum isolation: 80 dB

Switch off pulse modulation.

Maximum transmission loss: 1 dB

## 5.2.2 Checking the Rise and Fall Times

Test setup:

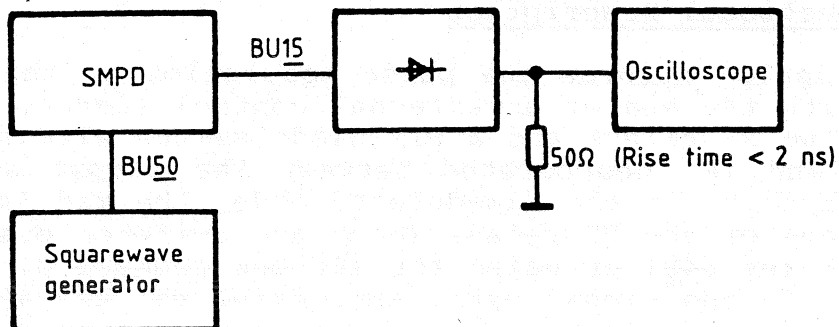

Settings on SMPD: 10 dBm, 500 to 2720 MHz  
 Squarewave generator: 1 MHz, 50% duty cycle,  
 TTL level

Maximum rise time (10% RF → 90% RF): 10 ns  
 Maximum fall time (90% RF → 10% RF): 10 ns

## 5.3 Interfaces

BU	600 (input)	601 (output)	50 (PM ⊕)	505.3 (Y100)
f	0.005/ 500 to 2720 MHz	0.005/ 500 to 2720 MHz	0 to 1 MHz	DC
Level	....14 dBm	....13 dBm	TTL	0/+12 V
R <sub>i</sub>	50 Ω	50 Ω/n.d.	-	-
AC-DC	AC	AC	AC	DC
Curve	Sinewave	Sinewave	Squarewave	DC

#### 5.4 Retrofitting the Pulse Modulator Option

Screw wired-up pulse modulator onto carrier plate. Remove front-panel section and output amplifier and unscrew K518 from BU1 (Y30) and BU197 (Y15).

Screw K600 of the option to BU197 (Y15) and BU600 (option). Run cable from BU197 behind the output amplifier parallel to cross-member of chassis and vertical to BU600 of the option.

Screw K601 of the option to BU1 (Y30) and BU601 (option). Run cable parallel to K600.

Undo front-panel mask, fit the pulse modulation switch unit in the cutout provided and connect cable K510 (Y19).

Fit front-panel section together with new mask and link K503 of the pulse modulation switch unit with ST503 of the controller (Y100). Connect K605 with the control input (cont) of the pulse modulator.

Remove processor (Y1) and solder a link between pins 12 and 8 of chip B36.





ROHDE & SCHWARZ  
MÜNCHEN

Schalteillisten  
Stromläufe  
Bestückungspläne  
Parts lists  
Circuit diagrams  
Components plans

**ROHDE & SCHWARZ**

ÄZ

Datum  
DateSchaltteilliste für  
Parts list forSMPD-B1 PULSMODULATOR  
SMPD-B1 PULSE MODULATIONSachnummer  
Stock No.

377.0914.01 SA

Blatt  
Page

1

05 0686

Kennzeichen Component No.	Benennung/Beschreibung Designation	Sachnummer Stock No.	enthalten in contained in
B1	BM MW121T10HUS PINDIO.SW PIN DIODE SWITCH AEL-ISRAEL MW-121T10 HVD	339.0956	
C1	CK 100NF+-5%63V5RM MKT CAPACITOR WIMA MKS/2/63/0,1UF/5%	CK 099.2930	
C2	CK 100NF+-5%63V5RM MKT CAPACITOR WIMA MKS/2/63/0,1UF/5%	CK 099.2930	
GL504	AG 1N4007 GL1000V 1A0 RECTIFIER	AG 013.0310	
GL510	AEG-TELEF 1N4007 AF QLMP1379 LED RT RD3 LED HEWLETT QLMP 1379	AF 257.4736	377.0920.01
K504	DX KABEL CABLE	377.0620	
K600	DX HF-KABEL RF CABLE	377.0966	
K601	DX HF-KABEL RF CABLE	377.0972	
K602	DX HF-KABEL RF CABLE	377.0989	
K603	DX HF-KABEL RF CABLE	377.0995	
K604	DX HF-KABEL RF CABLE	377.1004	
K605	DX HF-KABEL RF CABLE	377.1010	
RS1	SH HF-REL.12V SMA-ANSCHL. RELAY TELEDYNE R&S.ZCHNG.242.3016.	242.3016	
RS2	SH HF-REL.12V SMA-ANSCHL. RELAY TELEDYNE R&S.ZCHNG.242.3016	242.3016	
S510	SB TASTER 1POL.DOPPELKONT PUSHBUTTON SWITCH PREH 75 120-001	292.0340	377.0920.01
ST510	FP WINKELSTECKERLEIST.36P ANGLE PIN CONNECTOR BERG 75168-113-36 2-POLIG	FP 243.3578	377.0920.01
Y106	ED PM-TASTE PM KEY	377.0920.02	
Z1	BD HOCHPASS 470MHZ HIGHPASS FILTER 470MHZ DUENNFILMSPEZIALTEIL	915.0700	

377.0914.01 SA BL 1+

Für diese Unterlage behalten wir  
uns alle Rechte vor





**ROHDE & SCHWARZ**

ÄZ  
05

Datum  
Date  
0686

Schaltteilliste für  
Parts list for  
SMPD-B1 PULSMODULATOR  
SMPD-B1 PULSE MODULATION

Sachnummer  
Stock No.

377.0914.01 SA

Blatt  
Page  
2

Kennzeichen Component No.	Benennung/Beschreibung Designation	Sachnummer Stock No.	enthalten in contained in
	SPEC. THIN FILM CIRCUIT		- ENDE -

Für diese Unterlage behalten wir  
uns alle Rechte vor

Name	
Datum	
And-Mittg-Nr.	
And-zust.	
Name	
Datum	
And-Mittg-Nr.	
And-zust.	

Diese Zeichnung ist unser Eigentum. Vervielfältigung, unbefugte Verwendung, Mitteilung an andere ist strafbar und schadenersatzpflichtig.

ROHDE & SCHWARZ · MÜNCHEN

Name			
Datum	8.84	8.86	
And-Mittg-Nr.	32903	32958	
And-zust.	A	B	
Name	GU	CO	
Datum	5.84	5.84	
gezeichnet			
bearbeitet			
geprüft			
normgepr.			

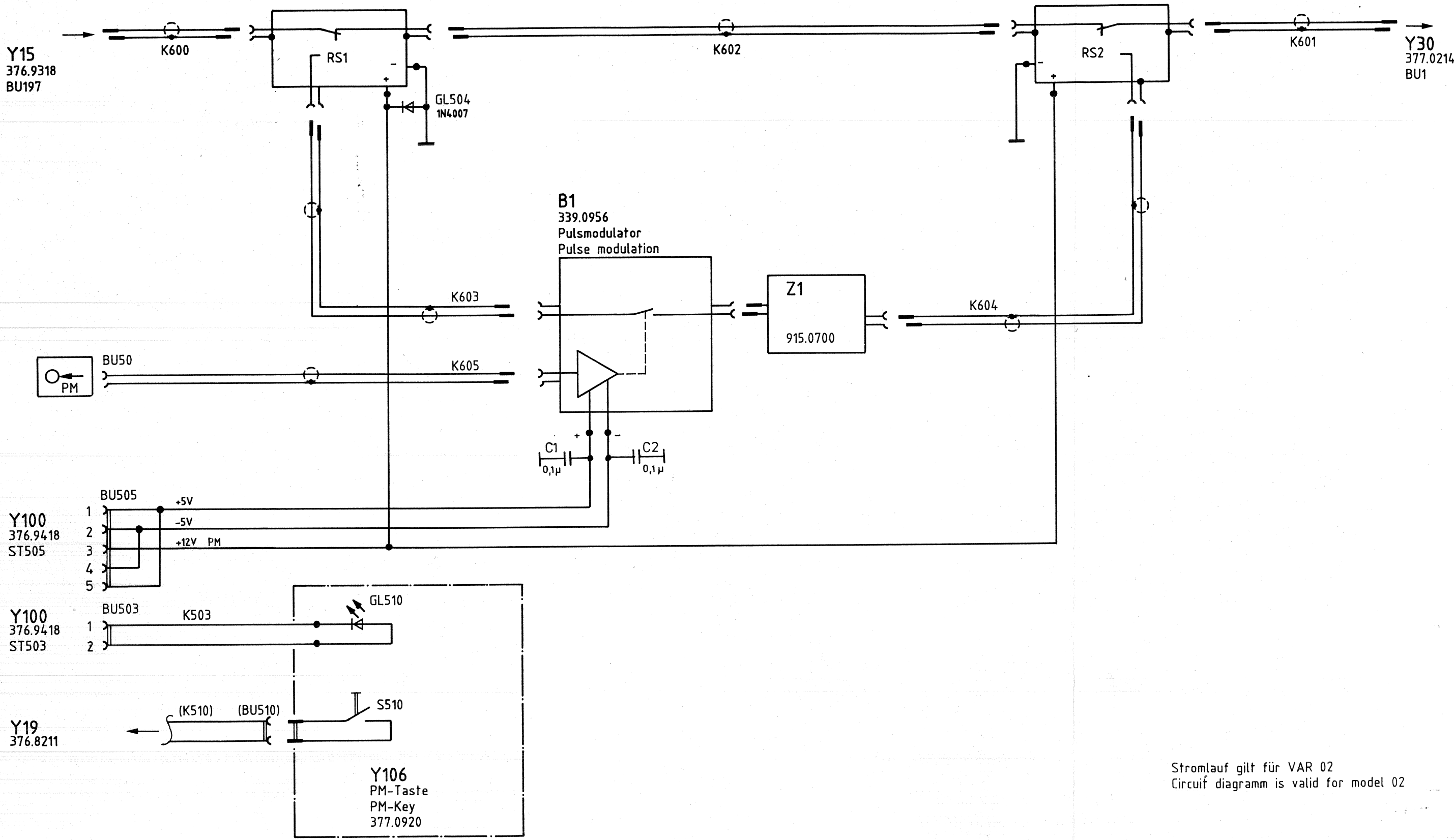

Stromlauf gilt für VAR 02  
Circuit diagram is valid for model 02

	Stromlauf zu	SMPD-B1 Pulsmodulator Pulse modulation	Z	Zeichn. Nr. <b>377.0914 S</b>
				reg. iV 377.0914 V

Ansicht und Leitungsführung Bauteilseite  
View of tracks on component side

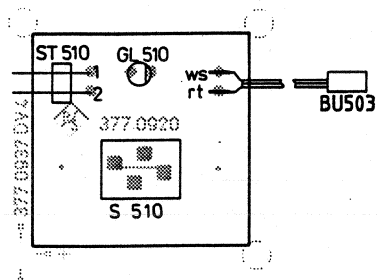

Ansicht und Leitungsführung Lötseite  
View of tracks on solder side

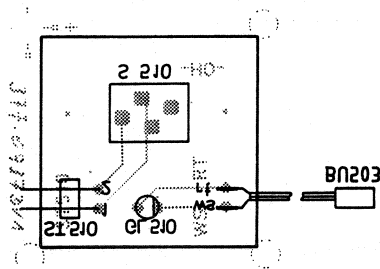

Für diese Unterlage behalten wir uns alle Rechte vor.

				Maße ohne Toleranzangabe		Maßstab 1 : 1			
						Halbzeug, Werkstoff			
				<b>1KGA</b>	Tag	Name	Benennung <b>PM-Taste PM-Key</b>		<b>Z</b>
				Bearb.	<b>03.84</b>	<b>CO</b>			
				Gepr.					
				Norm					
						Zeichn.-Nr.		Blatt-Nr. <b>2</b>	
						<b>377.0920</b>			
And Zust	Anderungs-Mitteilung	Tag	Name	zu Gerät		reg. i. V.	<b>377.0914 V</b>	erste Z	<b>377.0914</b>





**ROHDE & SCHWARZ**

SERVICE INSTRUCTIONS

Overload Protection Option

SMPD-B2 377.1110

# Table of Contents

		Page
<u>5</u>	<u>Service Instructions for Overload Protection</u>	
	<u>Option SMPD-B2 377.1110</u> .....	5.1
5.1	Circuit Description .....	5.1
5.2	Checking and Adjustment Procedures .....	5.2
5.2.1	Setting the Response Threshold of the Overload Protection .....	5.2
5.2.2	Checking the Overload Protection .....	5.2
5.3	Interfaces .....	5.3
5.4	Retrofitting of the Overload Protection Option SMPD-B2 .....	5.4
	Block diagram (Fig. 5-1)	
	Parts lists	
	Circuit diagrams	

### 5.1 Circuit Description

(See circuit diagram 377.1110 S and Fig. 5-1 as well as circuit diagram 377.0214 of subassembly Y30)

For protection of the RF attenuator Y30 the RF ON/OFF contact at the attenuator output is opened in the case of overloading. During the response time of the ON/OFF contact the output of the SMPD is short-circuited by means of a PIN diode in the overload test probe.

The Overload Protection consists of the overload test probe (915.1306), the comparator and control circuit on the control board for RF attenuator and overload protection (377.0220) and the RF ON/OFF contact in the RF attenuator (302.7311). The overload test probe is inserted at the output of the RF attenuator. It is connected via the coaxial cable K40 to the attenuator and via the coaxial cable 41 to the RF output socket.

The RF voltage is rectified in the overload test probe. The rectified voltage is brought out at the lead-through filter D1 and a DC voltage is brought out via the series-connected resistor at the lead-through filter D2. The PIN diode is supplied with a switching voltage via lead-through filter D3.

The lead-through filters D1, D2 and D3 are connected via the three-core line BU231 to the control board for RF attenuator and overload protection. The comparators B6I and B6II and the mono-stable B3 produce a control signal when the response level is exceeded with delayed reset for turning on the PIN diode and to open the RF ON/OFF contact. The PIN diode is turned on with +1.6 V and blocked with -15 V on D3. The RF ON/OFF contact is open if the logic control level is high (pin 1, BU10 of Y301) and closed if the logic control level is low. The information that the overload protection has responded is sent from the output B2II via BU300, pin 13 to the microprocessor which in turn keeps the RF ON/OFF contact open ("OFF" in the level display) via the flip-flop B5 (with D0 = 1 and strobe 2). By pressing the LEV MIN key the RF ON/OFF contact can be closed again.

## 5.2 Checking and Adjustment Procedures

### 5.2.1 Setting the Response Threshold of the Overload Protection

#### **Test setup:**

Connect a power signal generator to the RF socket of the SMPD.

#### **Settings on the SMPD:**

1000 MHz, 10 dBm, potentiometer R11 of control board for RF attenuator and overload protection (377.0220) turned fully clockwise.

#### **Settings on the power signal generator:**

Frequency between 900 and 1000 MHz, 24 dBm.

Measure the DC voltage at the lead-through filter D1 of the overload test probe (915.1306). Vary the frequency on the power signal generator between 900 and 1000 MHz and find voltage minimum. It should be  $100 \pm 30$  mV. Increase the output power of the power signal generator to 29 dBm and then turn R11 counterclockwise until the overload protection responds. Subsequently reduce the output power of the power signal generator to 10 dBm and release the overload protection by pressing the LEV MIN key. Increase the power of the power signal generator and check the response threshold. It must be at  $29 \pm 0.5$  dBm.

### 5.2.2 Checking the Overload Protection

Connect power signal generator to the RF output socket of the SMPD. The response threshold of the overload protection depends on the frequency of the signal fed in and the level of the SMPD.

The response threshold must under all circumstances be between 23 and 30 dBm of the level fed in.

Connect a power supply (0 to 10 V) to the RF output socket of the SMPD. The response threshold of the overload protection for DC voltages of either polarity should be between 4 and 7 V.



Digital interfaces:

Terminal	Logic level	Description
BU300, pin 13	1	Interrupt to microprocessor in the case of overloading
BU300, pin 10	1	Microprocessor control of RF ON/OFF contact with strobe 2 and DØ
BU300, pin 2	1	Strobe 2
BU300, pin 2	0	RF ON/OFF contact open (DØ = 1)
BU300, pin 2	0	RF ON/OFF contact closed (DØ = 0)
BU10, pin 10	1	Control signal of RF ON/OFF Contact open
BU10, pin 10	1	Contact closed

Analog interfaces:

Terminal	Logic level	Description
D1	350 mV	Response threshold of the overload protection if overload with an RF signal
D2	±(4 to 7)V	a DC voltage
D3	-15 V	Switching voltage on D3
D3	+1.4 V	Voltage drop on overload

Response threshold of the overload protection if overload with

- an RF signal ..... 350 mV D1
  - a DC voltage ..... ±(4 to 7)V D2
- Switching voltage on D3:
- Normal operation ..... -15 V D3
  - Voltage drop on overload ..... +1.4 V D3

Retrofitting of the Overload Protection  
Option SMPD-B2

Unscrew solid-jacket cable K27 from the RF output socket. Loosen the four screws in the corners of the front panel and take off the front panel. Unscrew cable K27 from socket BU2 of the attenuator.

Screw the angle bracket (346.1077) with the mounted overload test probe (915.1306) to the vacant threaded hole in the middle on the attenuator base plate so that the overload test probe is placed above the attenuator (screw M3 x 6). Screw the coaxial cable K40 between socket BU2 of the attenuator and the overload test probe. Screw cable K41 on to the SMA socket of the overload test probe. Plug BU231 into ST231 of the control board for RF attenuator and overload protection (377.0220). The contact marked 1 on BU231 must mate with the pin marked 1 on ST 231.

Replace front panel. Carefully bend cable K41 until it is properly located and screw to RF output socket. Fasten the front panel with the four screws.

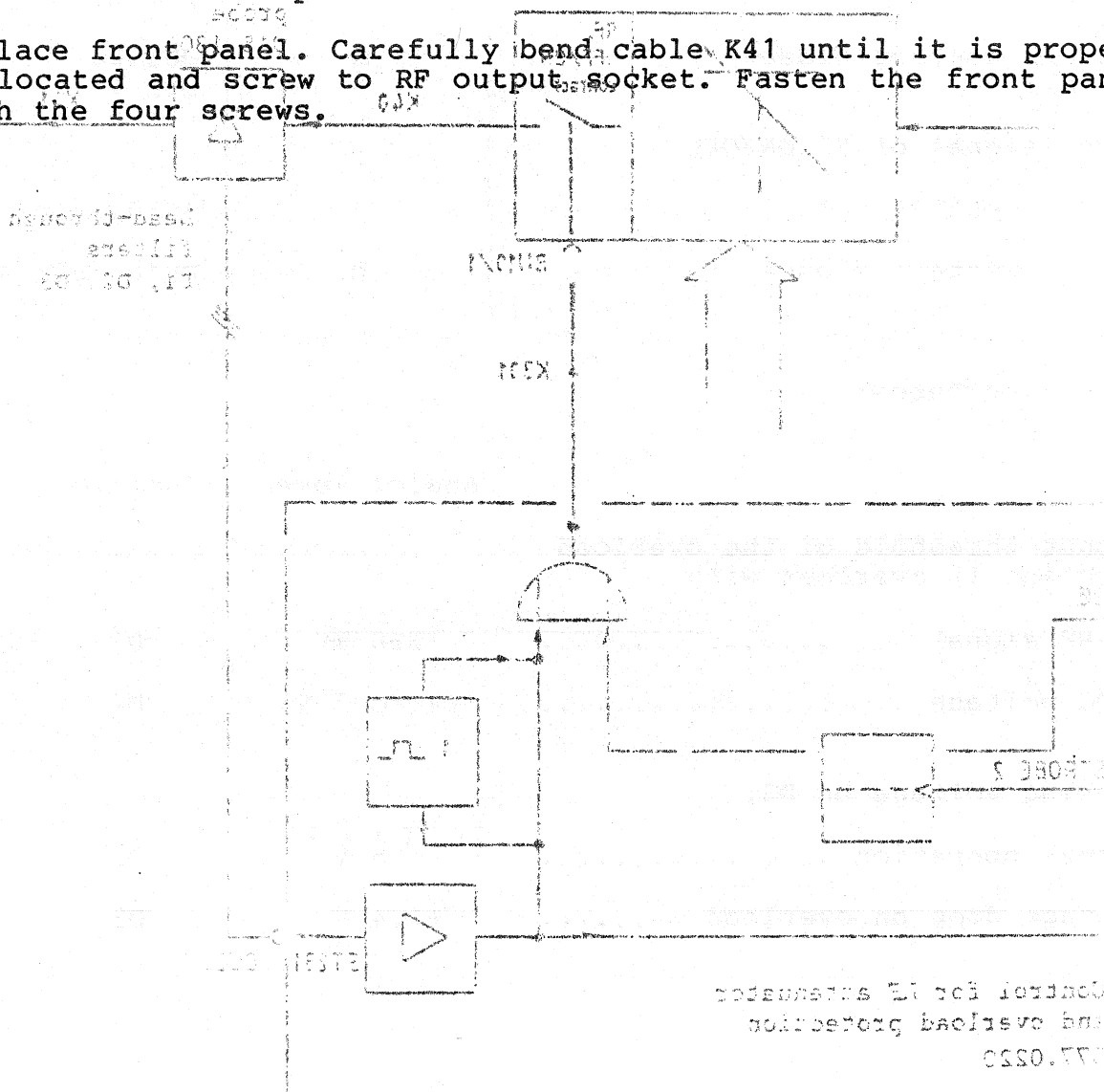





ROHDE & SCHWARZ  
MÜNCHEN

Schaltteillisten  
Stromläufe  
Bestückungspläne  
Parts lists  
Circuit diagrams  
Components plans



**ROHDE & SCHWARZ**

AZ

Datum

Date

03

0686

Schalteilleiste für

Parts list for

SMPD-B2 UEBERSPGS.SCHUTZ

OVERLOAD PROTECTION

Sachnummer

Stock No.

377.1110.01

SA

Blatt

Page

1

Kennzeichen Component No.	Benennung/Beschreibung Designation	Sachnummer Stock No.	enthalten in contained in
BU231	DX BUCHSENEINHEIT SOCKET UNIT	377.1140	
C1	CC 150NF+-10% 50V8K1200LR CAPACITOR AEROVOX CKR06BX154K LEVELR	CC 092.0919	
K40	DX HF-KABEL RF CABLE	346.1048	
K41	DX HF-KABEL RF CABLE	377.1133	
Y1	BD UEBERSPANNUNGSSCHUTZ OVERVOLTAGE PROTECTION	915.1306	
			- ENDE -

Für diese Unterlage behalten wir  
uns alle Rechte vor

377.1110.01 SA BL 1-

